

# Grundfos SQ/SQE Data Book

ELECTRONICS



COMMUNICATIONS

P E R F O R M A N C E

# GRUNDFOS®



# Table of Contents

**SQ/SQE Features and Benefits** ..... pages 4-6

**Applications** ..... pages 7-9

**Communications** ..... pages 10-13

**Performance Data** ..... pages 15-31

**Technical Data & Accessories** ..... pages 32-36

# Features and Benefits

## SQ/SQE Submersible Pumps

SQ/SQE pumps are suitable for both continuous and intermittent operation for a variety of applications:

- Domestic water supply
- Small waterworks
- Irrigation
- Tank applications

### SQ, SQE pumps offer the following features:

- Dry-Run protection
- High efficiency pump and motor
- Excellent wear resistance, and sand handling capabilities
- Protection against up-thrust
- Soft-start
- Over-voltage and under-voltage protection
- Overload protection
- Over-temperature protection
- High starting torque

Additionally, the SQE pumps offer:

- Constant pressure control
- Variable speed
- Electronic control and communication

The SQ and SQE pump models incorporate a totally new motor design. With the use of permanent-magnet technology within the motor, the SQ/SQE pumps deliver unmatched performance. By combining permanent-magnet motors and Grundfos's own micro frequency converter, we are now able to control and communicate with the pump in ways never before possible. A few of the features that come out this combination are Constant Pressure Control, Soft-Start, and integrated Dry-Run protection. These are just a few of the many features that the SQ/SQE pumps can offer.

The SQ pump models are a simple pump that operates at a constant speed much like today's conventional pumps. The difference between it and today's pumps is you get all the benefits of an electronically controlled permanent-magnet motor that cannot be accomplished with a conventional induction motor. The SQ pumps are available for single phase power. They use a simple 2-wire design making installation easy.

The SQE uses the Grundfos "Smart Motor". Like the SQ model, we still use the high efficiency permanent magnet motor, but we give this motor the ability to communicate. The "Smart Motor" communicates via the CU300 status box through the power leads. It is not necessary to run any additional wires down the well. By being able to communicate with the pump you can have Constant Pressure Control and the ability to change the pump

performance while the pump is installed in the well. Like the SQ motor, this is also a 2-wire motor designed for single-phase operation.

The CU300 status box also allows you to communicate with the "Smart Motor" with the R100 infrared remote control. The R100 gives you the ability to monitor and setup your pumping system to meet the specific needs of your application. It is also important to note the "Smart Motor" can operate without the CU300, but you will lose some of the functions that are only possible by using the CU300.

The CU300 provides full control of the SQE pumps. If the pump stops, the CU300 will illuminate a light on the front panel. If you have an R100 you will be able to trouble shoot the system and recall the last five causes of failure.

## Pump and Motor Range

Product	Description	Material
SQ/SQE Pump	5,10,15,22,30 gpm	Stainless steel AISI 304
SQ-MS 3 Motor	Single-phase 1/3 - 1.5 Hp	Stainless steel AISI 304
SQE-MSE 3 Motor "Smart Motor"	Single-phase 1/3 - 1.5 Hp	Stainless steel AISI 304

## Pipe Connection

Pump Type	Threaded Connection
SQ/SQE 5	1" NPT
SQ/SQE 10,15	1 1/4" NPT
SQ/SQE 22, 30	1 1/2" NPT

## Type key

Example 10 SQ E 05 A 160 -NE

Nominal flow GPM \_\_\_\_\_ 10

Type range \_\_\_\_\_ SQ

Electronic control/communication \_\_\_\_\_ E

Horsepower \_\_\_\_\_ 05

Motor designation \_\_\_\_\_ A

Head in ft at nominal flow rate \_\_\_\_\_ 160

Material specification \_\_\_\_\_ -NE

## Operating Conditions

Flow velocity past motor	Max. liquid temperature
0.0 f/s (Free convection)	86°F (30°C)
Min. 0.5 f/s	104° F (40°C)

## Dry-Run Protection

The SQ and SQE incorporate integrated Dry-Run protection. When the water level falls below the inlet of the pump the pump will shut off. After a period of time, the pump will then automatically start up again.

For the SQ pumps the cut-off level is factory-set. For the SQE pumps you must set this level by using a CU300 and R100.

## High Motor Efficiency

The SQ and SQE motors are based on a permanent magnet rotor which produce high efficiency within a wide load range. The high and flat efficiency curve of the Permanent-Magnet motor allows for a coverage of a wide power range with the same motor, as compared to conventional AC motors. For SQE pumps, this means three motors to cover the horsepower range from 1/3 to 1.5Hp.

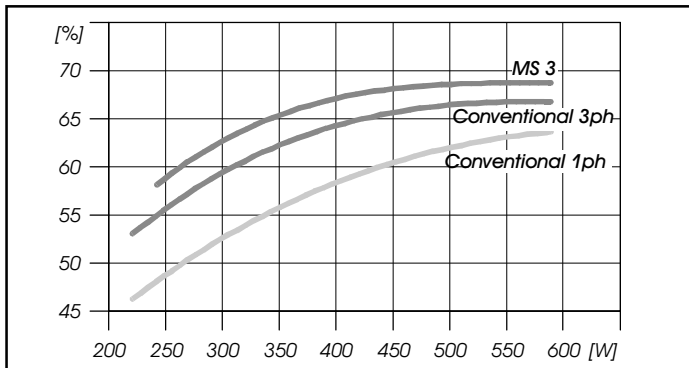

## High Pump Efficiency

The pump components are made from a 30% glass filled engineered composite. The pumps are designed to deliver at peak efficiency levels. Because of high pump efficiencies, overall power consumption will be reduced.

## Excellent Wear Resistance

The SQ/SQE pump design uses “floating” impellers. Each impeller has its own tungsten carbide/ceramic bearing. This design and the high quality materials make the pump very wear resistant especially in sandy conditions.

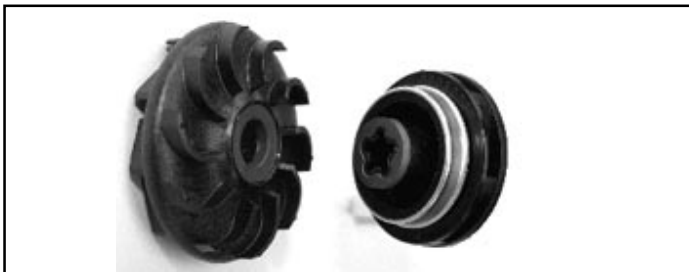

## Protection against up-thrust

During start-up many pumps start in an up-thrust condition. To prevent damage caused by up-thrust a top bearing has been placed in the motor to protect both the pump and the motor against up-thrust.

## Soft-Start

Both the SQ and SQE motors have a soft start because of the integrated electronics. Soft start reduces the starting current and gives the pump a smooth and steady acceleration.

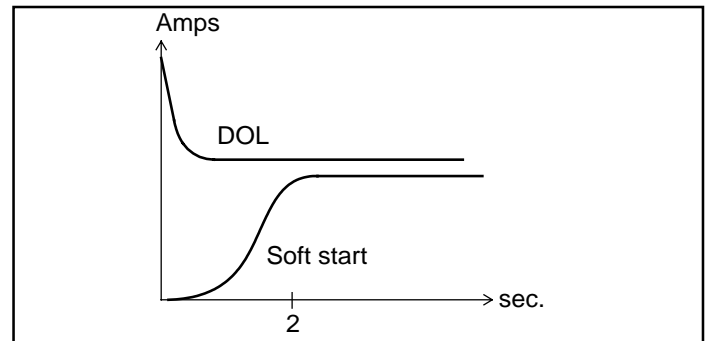

The soft-start will reduce your chance of water hammer, minimizes the risk of wear and prevent overloading of your circuit during start-up.

## High Starting Torque

Because of the permanent-magnet motor the SQ/SQE pumps have excellent starting capabilities. The high locked rotor torque produced by the PM motor provides a starting torque that is 1.5 times greater than conventional pump motors. Even if the voltage is low the PM motor will still maintain a high starting torque.

## Overvoltage and Undervoltage Protection

Overvoltage and undervoltage may occur at anytime especially if you have an unstable voltage supply.

The integrated voltage protection of the SQ and SQE motors protects the motors when the voltage falls outside the permissible voltage range.

The 230V pump will cut out if voltage falls below 150V or above 280V. The motor will automatically start when the voltage is within the permissible voltage range. It is not necessary to have additional voltage protection.

## Overload Protection

When the pump load rises above the maximum amp level, the motor will automatically compensate and reduce the speed to maintain its maximum amp level. If the speed drops to 65% of the nominal speed, the motor will shut off.

# Features and Benefits

## Overtemperature Protection

Permanent-magnet motors emit very little heat because of their high efficiency. The SQ and SQE motors are designed with an internal circulation system to effectively cool all the internal motor components.

As extra protection, the electronic unit also has a built-in temperature sensor. When the temperature rises too high, the motor will shut off; when the temperature drops, the motor will automatically restart.

## Reliability

The SQ and SQE motors have been designed to withstand the toughest of applications and provide reliability. Some of those features are:

- Tungsten carbide/ceramic bearings
- Thrust bearings protecting against down-thrust
- Product lifetime equal or greater than conventional AC motors and 4" pumps

## Variable Speed

The SQE "Smart Motor" enables continuous variable speed control within 65% - 100% (7000-10700 rpm) of motor speed. The pump can be set to operate at any duty point in the range between 65% and 100% of the pump's performance curve. Your pump can then be adapted to any specific requirement. The variable speed control requires the CU300 control unit and the R100.

To help you decide on the proper speed, we have made available a speed calculation program called "SQE – Speed Calculation". This program is available as an option.

## Variable Speed Range of Operation

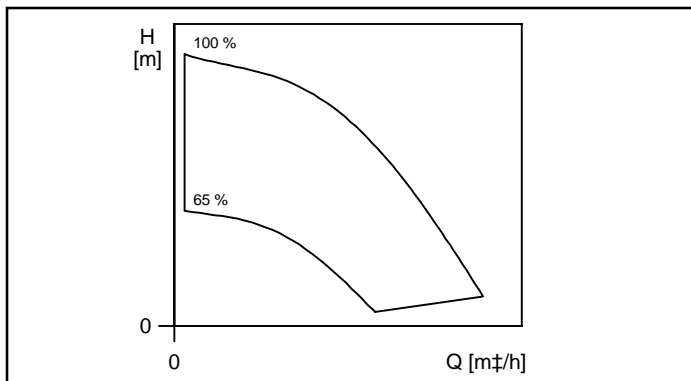

## Installation

The SQ and SQE may be installed vertically or horizontally.

**Note:** The pump must not fall below the horizontal level in relation to the motor.

The following features ensure simple installation of the SQ and SQE pumps:

- Built-in spring loaded check-valve
- Light weight makes it easy to install
- Fits in 3" or larger wells

For horizontal installation, a flow sleeve is recommended in order to:

- Ensure sufficient flow past the motor to provide sufficient cooling
- Prevent the unit from being buried in sand or mud

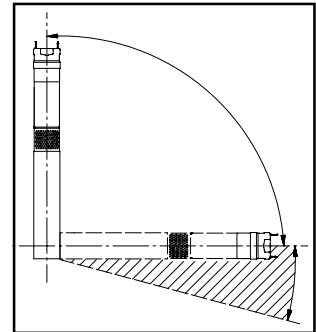

## Service

The modular design of the pump and motor makes it easy to repair and service. The motor lead is also replaceable.

## SQ with Pressure Switch and Diaphragm Tank

SQ is the perfect pump for domestic water supply. The SQ is easy to sell, install and operate.

### Replacement in Existing Installation

SQ and SQE pumps can be installed as replacement of a 4" submersible pump in an existing installation. By replacing an existing 4" pump with an SQ or SQE, you not only get the most advanced pump on the market, but you also have the ability to upgrade your system to a constant pressure system as shown on page 8.

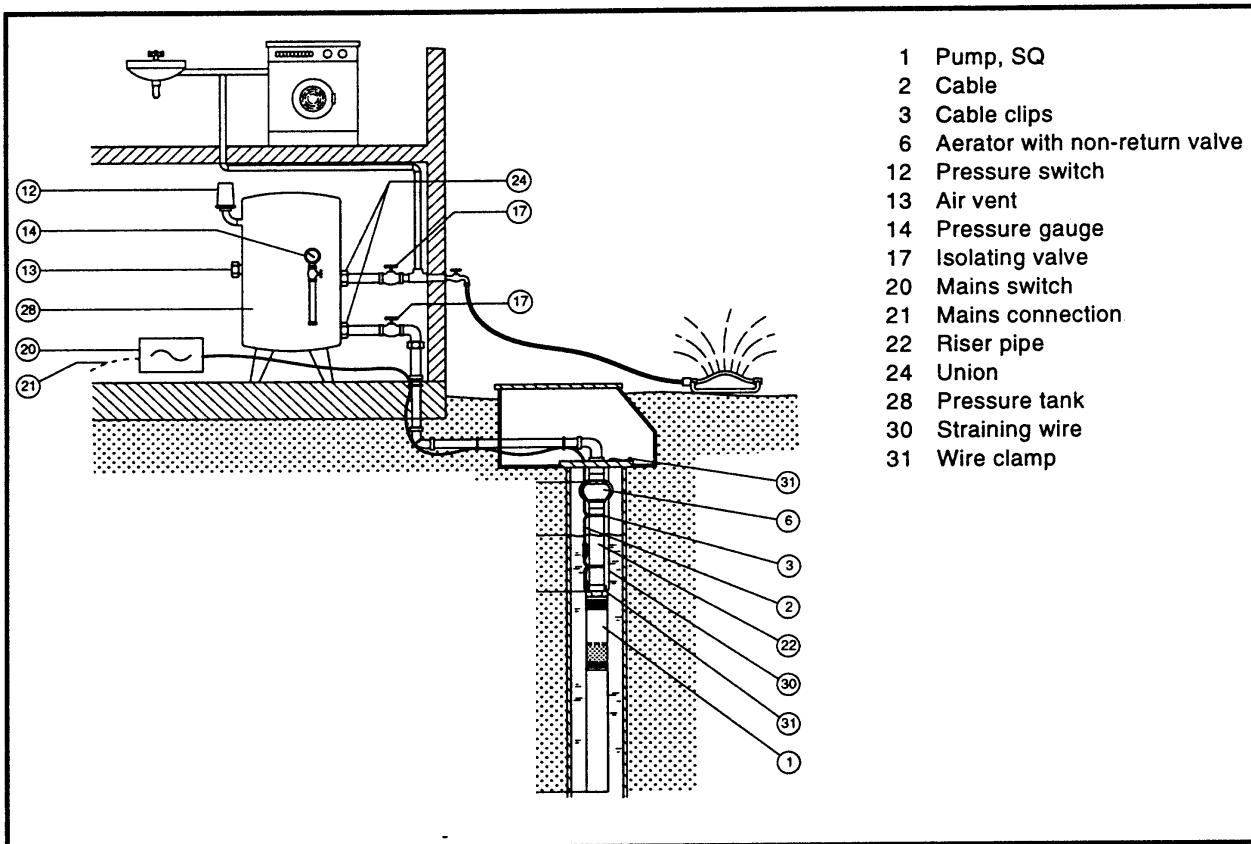

TM01 2988 2898

# Applications

## SQE with Constant Pressure Control

### Function and Benefits

Constant pressure can be maintained in the system to provide you with “city like” water pressure. A flow switch starts the pump once the tap is opened. A preset pressure is maintained via the pressure sensor and the CU300. When the flow switch detects no flow, the tank is filled with water and the pump stops.

If consumption is below 0.8 gpm, the CU300 will start the pump when the pressure is 7 psi below the set-point. The pump will then stop when the pressure is 7 psi above the set-point.

When consumption is above 0.8 gpm, the CU300 will control the pump performance to keep the pressure within 3 psi of the set-point.

Constant pressure control reduces pressure variations, and allows you to use a tank as small as 2 gal. Without loss of comfort. In installations incorporating filters, pump operation will gradually adjust as the filter becomes plugged.

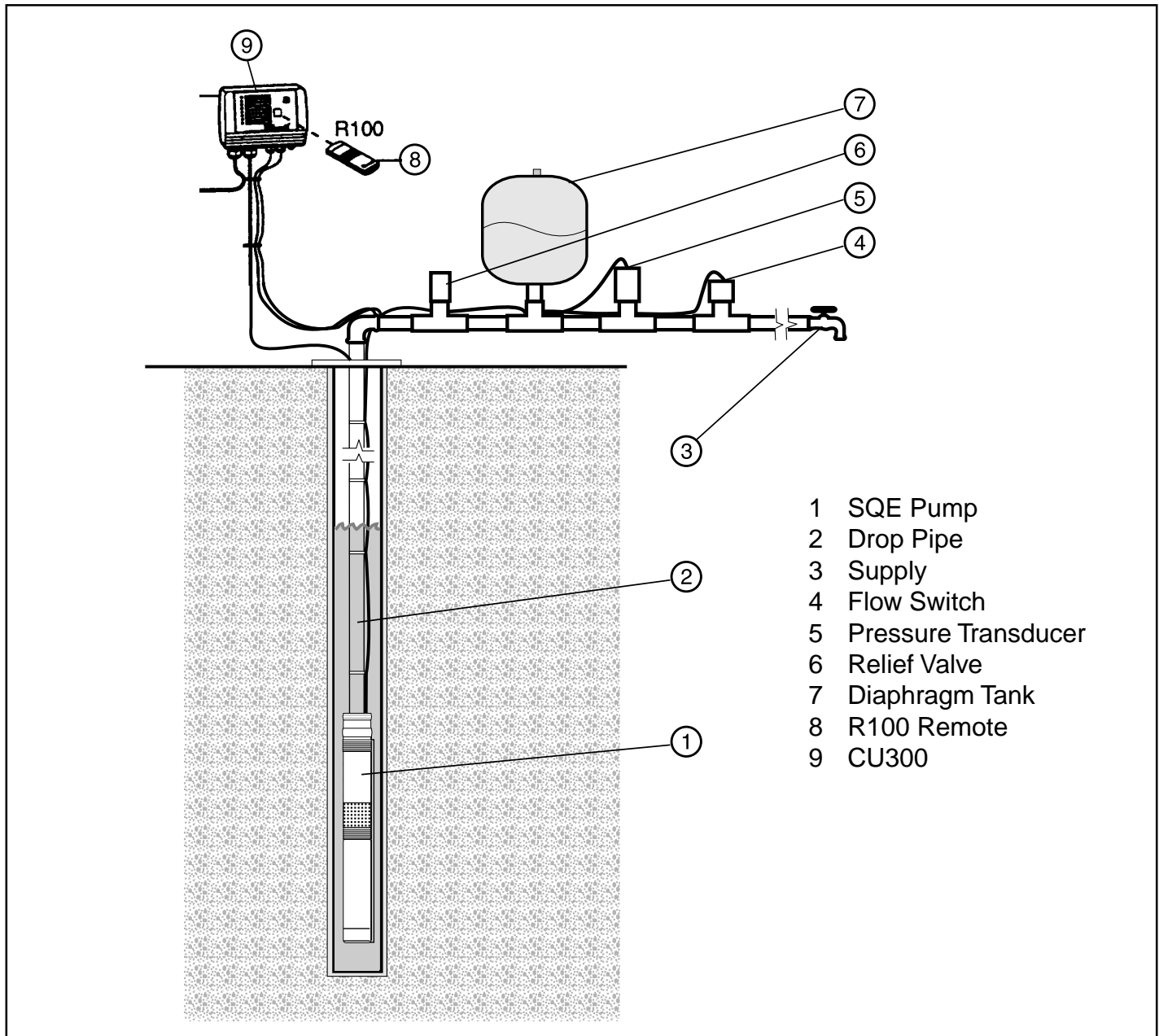



## Pumping from One Tank to Another

The SQE pump is ideal where there is a need to move water from one tank to another.

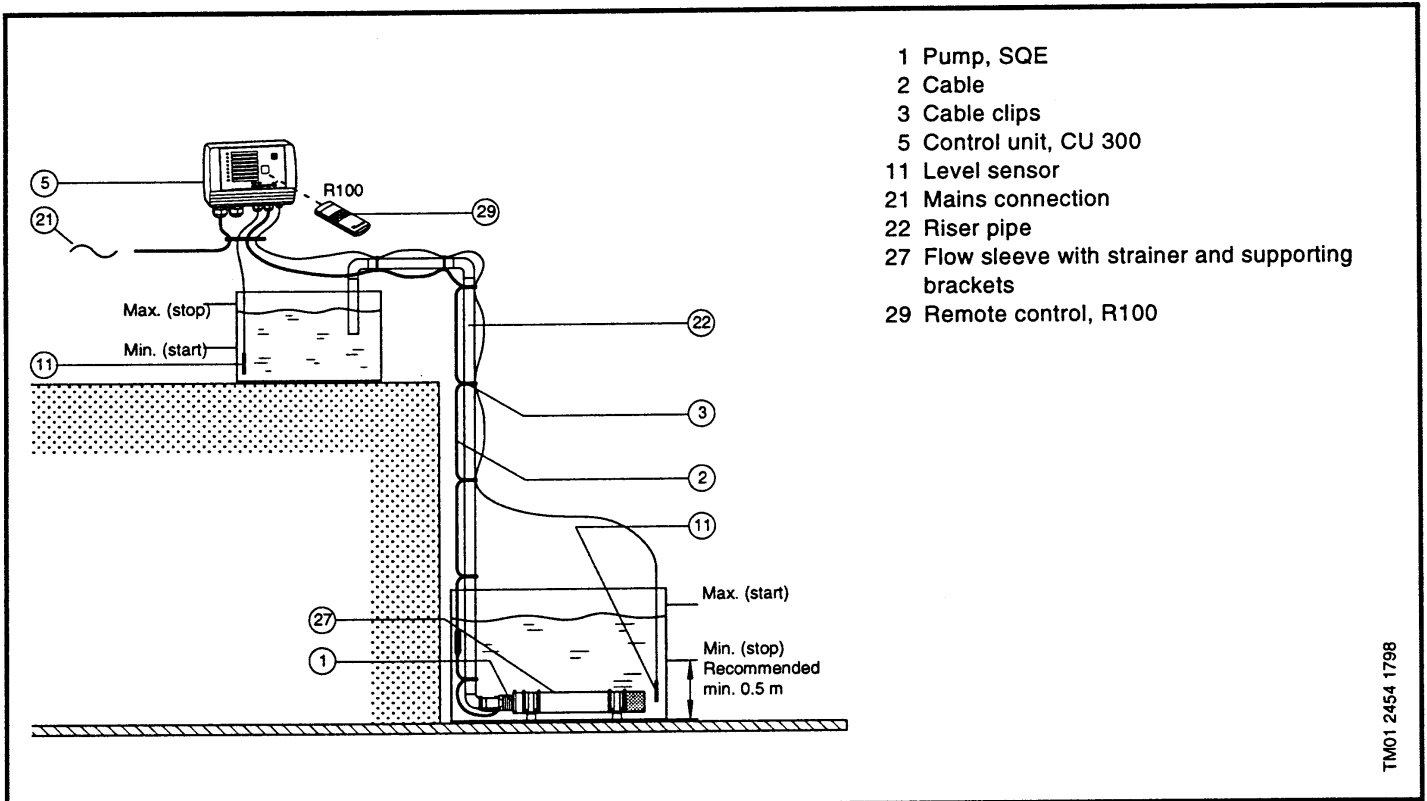

# Communication CU300

## CU300 Status Box

The CU300 status box is a control and communication unit especially developed for the SQE submersible pumps.

The CU300 status box provides:

- Easy adjustment to a specific well
- Full control of the SQE pumps
- Two-way communication with the SQE pumps
- Indicator lights on the front to indicate alarms
- The ability to start and stop the pump with the push of a button

The CU300 communicates with the pump using the power leads. It is not necessary to run any extra cables between the pump and the CU300 status box.

The following alarms can be indicated by the CU300:

- No contact
- Overvoltage
- Undervoltage
- Dry-Run
- Speed reduction
- Overtemperature
- Overload
- Sensor alarm

The CU300 incorporates:

- External signal input for three sensors
- Relay output for external alarm indication
- Control according to the signals received, e.g. flow pressure, water level and conductivity

The CU300 can communicate with the R100 infrared remote control.

## R100 Remote control

The R100 allows you to monitor the installation by reading current operating parameters, such as:

- Power consumption
- Energy consumption
- Number of operating hours

It allows you to change factory settings. A number of settings can be made, such as:

- Speed (performance)
- Constant pressure control mode
- De-watering function
- Automatic restart time

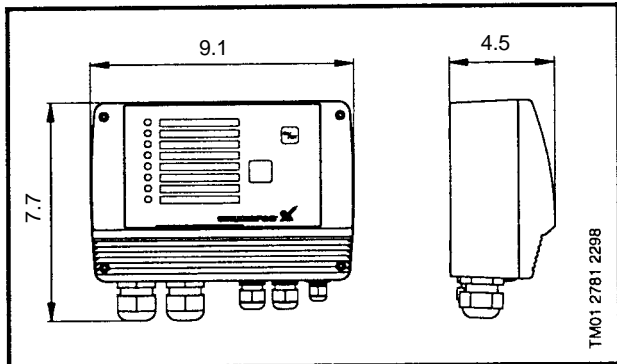
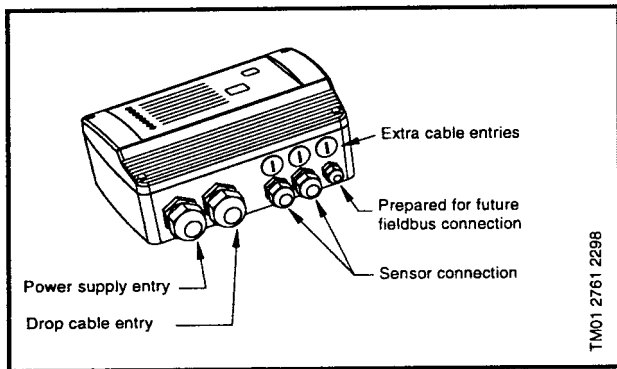
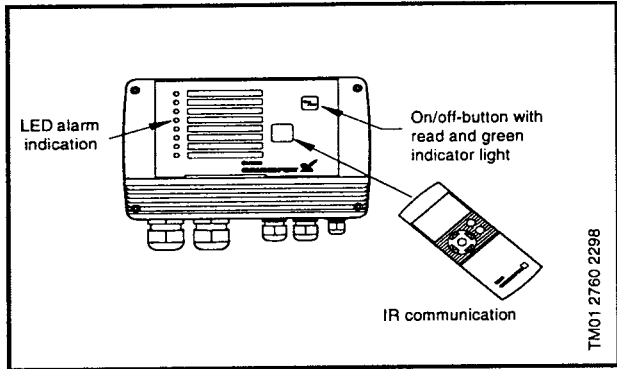

# R100 Menu Structure

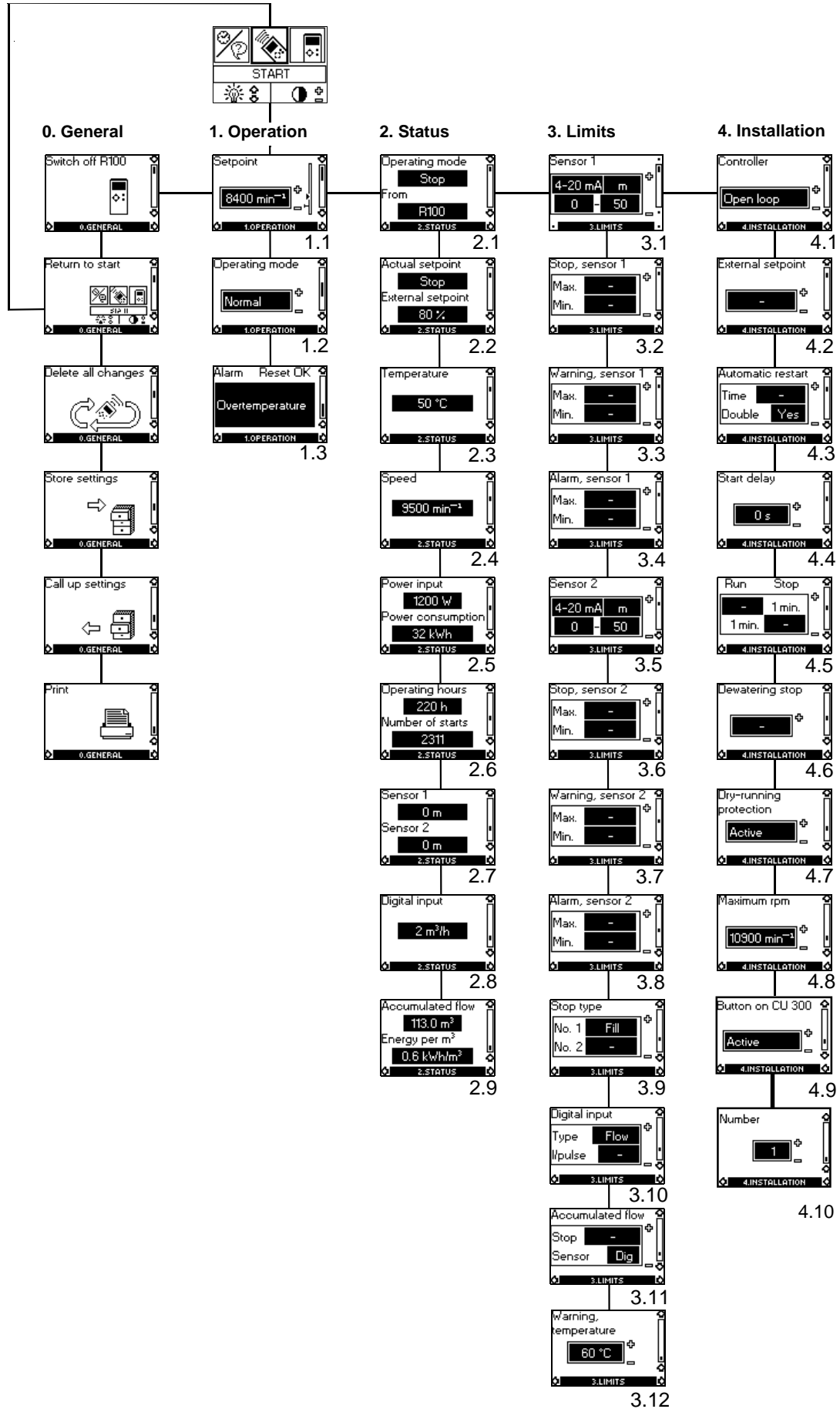

# R100 Menu Structure

## R100 Menu Structure for the CU300

### 0. General

#### 1. Operation

- 1.1 Set-point setting
- 1.2 Selection of operating mode
- 1.3 Alarm indication

#### 2. Status

The indication of:

- 2.1 Actual operating mode
- 2.2 Actual and external set point
- 2.3 Actual motor temperature
- 2.4 Actual motor speed
- 2.5 Actual power input and accumulated motor power consumption
- 2.6 Accumulated number of operating hours and accumulated number of starts
- 2.7 Actual values of sensors 1 and 2 respectively
- 2.8 Actual values of the digital input
- 2.9 Accumulated flow, and the power used to pump 1 gal.

R100 allows you to make a number of settings:

#### 3. Limits

The setting of:

- 3.1 Sensor 1
- 3.2 Min. and max. stop limit of sensor 1
- 3.3 Min. and max. warning limit of sensor 1
- 3.4 Min. and max. alarm limit of sensor 1
- 3.5 Sensor 2
- 3.6 Min. and max. stop limit of sensor 2
- 3.7 Min. and max. warning limit of sensor 2
- 3.8 Min. and max. alarm limit of sensor 2
- 3.9 Filling or emptying
- 3.10 Setting of the function of the digital sensor connected to the digital input
- 3.11 The setting of the water quantity stop limit and the setting of the sensor to detect water quantity
- 3.12 The setting of the temperature warning limits of the motor electronics

#### 4. Installation

- 4.1 Selection of controller
- 4.2 Setting of external set-point
- 4.3 Setting of automatic restart time
- 4.4 Allocation of individual start delays
- 4.5 Setting of the stop and run times for the de-watering function.
- 4.6 Setting of the minimum value of the pump power input
- 4.7 Activating or deactivating the Dry-Run protection.
- 4.8 Setting of the maximum motor speed
- 4.9 Activating or deactivating the on/off-button on the CU 300.
- 4.10 Allocation of number where more than one CU 300 is installed.

#### Status report

All settings and measured values can be transferred to a portable printer via wireless infrared communication and be printed in a status report.

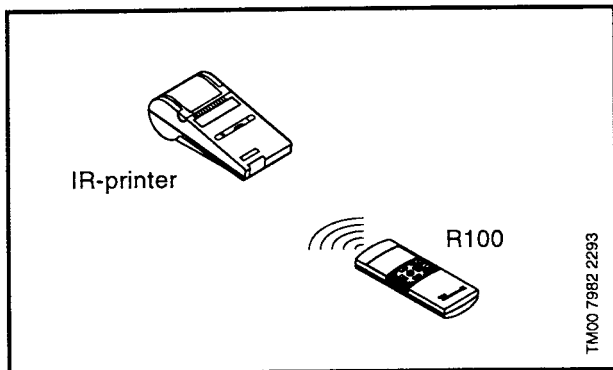

## Examples of R100 displays

### Menu OPERATION

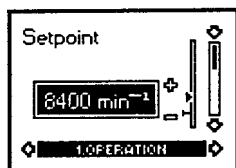

1.1

#### Set-point Setting

From the factory, the pump is set to maximum speed, 10,700 rpm. R100 allows you to reduce the pump speed by changing the setpoint. The speed can be set from 7,000 – 10,700 rpm, at 100 rpm intervals.

The unit of the set-point is automatically changed according to the unit of the sensor connection to sensor input no. 1.

EXAMPLE: Sensor input no. 1 is connected to a pressure sensor using the unit feet (ft.) and the range 0 – 200. Therefore, the set-point of display 1.1 can be set to between 0 – 200 ft.

### Menu STATUS

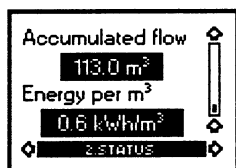

2.9

The displays appearing in this menu are status displays only. You cannot change settings in this menu.

#### Accumulated Flow

In display 2.9, the water quantity (gal.) pumped is shown. The value shown is the accumulated flow registered by the sensor selected in display 3.11.

The power used to pump 1 gal. is shown in the display as energy per gal. (kWh/gal.).

### Accumulated Number of Operating Hours and Number of Starts

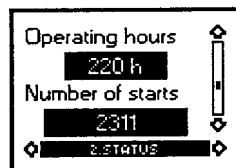

2.6

The value of operating hours and the number of starts are values accumulated from the time of installation and they cannot be reset.

Both values are stored in the motor electronics, and are kept even if the CU300 is replaced.

The number of operating hours is registered every two minutes of continuous operation.

### Menu LIMITS

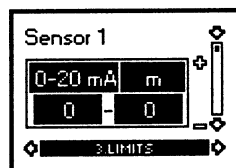

3.1

#### The Setting of Sensor 1.

Depending on the type of sensor, the following settings can be made:

Sensor outputs:  
(not active), 0-10V, 2-10V, 0-20 mA, 4-20mA.

Setting range unit: M<sup>3</sup>/h, m, %, gpm, ft.



# **Grundfos SQ/SQE Performance Data**

**5 SQ/SQE**

**SELECTION CHARTS**

FLOW RANGE

PUMP OUTLET

(Ratings are in GALLONS PER MINUTE-GPM)

(1.5 TO 8 GPM)

1" NPT

PUMP MODEL		HP	PSI	DEPTH TO PUMPING WATER LEVEL (LIFT) IN FEET																								
				20	40	60	80	100	120	140	160	180	200	220	240	260	280	300	340	400	460	520	600	700	800	900	1000	1100
5SQ/SQE03A-90	1/3	0	8	7.5	6.7	5.7	4.4	2.6	0.4																			
		20	6.5	5.5	4.2	2.3	0.1																					
		30	5.1	3.6	1.6																							
		40	3.6	1.5																								
		50	1																									
		60																										
SHUT-OFF PSI:				97	89	78	71	20	11	2																		
5SQ/SQE03A-140	1/3	0	8	7.7	7.3	6.7	6.1	5.5	4.7	3.7	2.6	1																
		20	7.1	6.6	6	5.3	4.5	3.5	2.2	0.6																		
		30	6.5	5.9	5.1	4.3	3.3	1.9																				
		40	5.8	5.1	4.1	3.2	1.8																					
		50	4.9	4	3	1.4																						
		60	3.8	2.6	1																							
SHUT-OFF PSI:				82	74	65	56	48	39	30	22	13	4															
5SQ/SQE05A-180	1/2	0			7.9	7.5	7.1	6.7	6.2	5.6	5.1	4.4	3.6	2.6	1.1													
		20	7.8	7.4	7	6.5	6.1	5.5	4.9	4.2	3.3	2.3	0.8															
		30	7.3	6.9	6.5	5.9	5.4	4.8	4.1	3.2	2	0.2																
		40	6.9	6.5	5.9	5.4	4.7	4	3.1	2	0.1																	
		50	6.3	5.8	5.3	4.6	3.8	2.9	1.6																			
		60	5.7	5.1	4.4	3.6	2.6	1.2																				
SHUT-OFF PSI:				110	102	93	84	76	67	58	50	41	33	24	15	7												
5SQ/SQE05B-230	1/2	0				8	7.7	7.3	6.9	6.5	6.1	5.6	5.1	4.6	4.1	3.4	2.8	0.8										
		20		8	7.6	7.1	6.8	6.3	5.9	5.4	5	4.5	3.9	3.3	2.6	1.8	0.6											
		30	7.9	7.5	7.1	6.7	6.3	5.9	5.4	4.9	4.4	3.8	3.1	2.4	1.5													
		40	7.5	7.1	6.7	6.3	5.8	5.4	4.9	4.3	3.7	3.1	2.3	1.4														
		50	7	6.6	6.2	5.8	5.3	4.8	4.2	3.6	2.9	2.2	1.2															
		60	6.5	6.1	5.6	5.1	4.6	4.1	3.4	2.8	2	0.9																
SHUT-OFF PSI:				143	134	126	117	108	100	91	82	74	65	56	48	39	30	22	4									
5SQ/SQE05B-270	1/2	0				8	7.8	7.5	7.2	6.8	6.5	6.1	5.8	5.3	4.9	4.4	3.4	1.2										
		20			8	7.7	7.4	7.1	6.7	6.4	6	5.6	5.2	4.8	4.3	3.8	3.2	1.8										
		30		8	7.7	7.3	7	6.7	6.3	5.9	5.5	5.1	4.7	4.2	3.7	3.1	2.4	0.8										
		40	8	7.7	7.3	7	6.7	6.3	5.9	5.5	5.1	4.7	4.2	3.7	3.1	2.4	1.6											
		50	7.6	7.3	6.9	6.6	6.2	5.9	5.2	5	4.6	4.1	3.5	3	2.2	1.5	0.6											
		60	7.2	6.9	6.5	6.1	5.7	5.3	4.9	4.4	3.9	3.4	2.7	2.1	1.2	0.2												
SHUT-OFF PSI:				175	167	158	149	141	132	123	115	106	97	89	80	71	63	54	37	11								
5SQ/SQE07B-320	3/4	0						7.9	7.6	7.3	7	6.7	6.4	6.1	5.7	5.4	4.6	3.4	1.6									
		20					7.8	7.5	7.2	6.9	6.6	6.3	6	5.6	5.3	4.9	4.5	3.9	2.1									
		30			8	7.7	7.5	7.1	6.9	6.5	6.2	5.9	5.5	5.2	4.8	4.4	4	3.1	1.2									
		40		8	7.7	7.5	7.1	6.9	6.5	6.2	5.9	5.5	5.2	4.8	4.4	4	3.5	2.5	0.2									
		50	7.9	7.6	7.4	7.1	6.8	6.5	6.1	5.8	5.5	5.1	4.7	4.3	3.9	3.5	3	1.9										
		60	7.6	7.3	7	6.7	6.4	6	5.7	5.4	5	4.6	4.2	3.8	3.3	2.8	2.2	0.8										
SHUT-OFF PSI:				249	240	232	223	214	206	197	188	180	171	162	154	145	136	128	110	84	58							
5SQ/SQE10C-360	1	0								8	7.7	7.4	7.2	6.9	6.6	6.3	6	5.4	4.4	3.3	1.9							
		20						7.9	7.6	7.3	7.1	6.8	6.5	6.2	5.9	5.6	5.3	4.7	3.6	2.3								
		30				8	7.8	7.6	7.3	7	6.7	6.5	6.2	5.9	5.6	5.3	4.9	4.3	3.1	1.6								
		40			8	7.8	7.5	7.3	7	6.7	6.5	6.1	5.9	5.6	5.3	4.9	4.6	3.9	2.6	0.8								
		50		0.8	7.8	7.5	7.2	7	6.7	6.4	6.1	5.8	5.5	5.2	4.9	4.5	4.2	3.3	2									
		60	8	7.7	7.4	7.2	6.9	6.6	6.3	6	5.7	5.4	5.1	4.8	4.4	4.1	3.7	2.9	1.2									
SHUT-OFF PSI:				234	227	219	210	201	193	184	175	167	158	149	141	132	123	115	97	71	46	20						
5SQ/SQE10C-410	1	0									7.9	7.6	7.4	7.1	6.8	6.5	6	5.1	4.2	3.2	1.4							
		20								7.8	7.6	7.3	7	6.7	6.5	6.2	5.9	5.3	3.6	3.4	2.3							
		30					8	7.8	7.5	7.3	7	6.7	6.4	6.1	5.9	5.6	5	4.1	3	1.7								
		40				8	7.8	7.5	7.3	7	6.7	6.4	6.1	5.8	5.6	5.3	4.7	3.7	2.6	1.1								
		50			8	7.7	7.4	7.2	6.9	6.6	6.3	6.1	5.8	5.5	5.2	4.9	4.3	3.3	2.1									
		60		7.9	7.6	7.4	7.1	6.8	6.5	6.3	6	5.7	5.4	5.1	4.8	4.5	3.9	2.8	1.4									
SHUT-OFF PSI:						249	240	232	223	214	206	197	188	180	171	162	154	145	128	102	76	50	15					
5SQ/SQE10C-450	1	0											7.9	7.6	7.4	7.1	6.6	5.8	5	4.1	2.9							
		20											7.9	7.6	7.3	7	6.7	6.5	6	5.1	4.3	3.4	2					
		30							8	7.8	7.5	7.2	6.9	6.7	6.4	6.1	5.6	4.8	4	3.1	1.5							
		40							8	7.8	7.5	7.2	6.9	6.6	6.4	6.2	5.9	5.4	4.5	3.7	2.7	0.8						
		50						8	7.7	7.5	7.2	6.9	6.6	6.4	6.1	5.9	5.6	5	4.2	3.3	2.3							
		60					7.9	7.6	7.4	7.1	6.8	6.6	6.3	6	5.8	5.5	5.2	4.7	3.8	2.9	1.7							
SHUT-OFF PSI:								264	255	247	238	229	221	212	203	194	186	177	160	134	108	82	48					



**10 SQ/SQE**

**SELECTION CHARTS**

FLOW RANGE  
(3 TO 15 GPM)

PUMP OUTLET  
1 1/4" NPT

(Ratings are in GALLONS PER MINUTE-GPM)

		DEPTH TO PUMPING WATER LEVEL (LIFT) IN FEET																													
PUMP MODEL	HP	PSI	20	40	60	80	100	120	140	160	180	200	220	240	260	280	300	340	400	460	520	600	700	800	900	1000	1100				
10SQ/SQE03A-110	1/3	0		14.8	13.5	12.5	11.0	9.0	6.0																						
		20	13.5	12.0	10.5	8.5	5.0																								
		30	11.8	10.0	8.0																										
		40	10.0	8.0																											
		50																													
		60																													
SHUT-OFF PSI:			56	48	35	30	17	13	4																						
10SQ/SQE05A-160	1/2	0			14.8	14.0	13.0	12.0	11.0	10.0	8.0	5.0																			
		20	14.6	13.8	13.0	12.0	11.0	9.5	7.5	4.0																					
		30	13.5	12.8	11.8	10.5	9.0	7.0	2.0																						
		40	12.8	11.8	10.5	9.0	7.0	2.0																							
		50	11.5	10.2	8.5	6.0																									
		60	10.0	8.0	5.0																										
SHUT-OFF PSI:			84	76	67	58	50	41	32	24	15	6																			
10SQ/SQE05B-200	1/2	0				14.8	14.0	13.5	12.8	12.0	11.0	10.0	9.0	7.0	5.0																
		20		14.5	14.0	13.3	12.5	11.8	10.8	9.8	8.5	6.5	4.0																		
		30	14.5	13.8	11.8	12.5	11.5	10.5	9.5	8.0	6.0	3.0																			
		40	13.8	13.0	12.5	11.5	10.5	9.5	8.0	6.0	3.0																				
		50	13.0	12.0	11.5	10.5	9.0	7.5	5.5	1.5																					
		60	12.0	11.0	10.0	9.0	7.0	5.0																							
SHUT-OFF PSI:			113	104	95	87	78	69	61	52	43	35	26	17	7																
10SQ/SQE07B-240	3/4	0					14.6	14.0	13.5	13.0	12.4	11.5	11.0	10.0	9.0	8.0	6.5	2.5													
		20		15.0	14.5	14.0	13.5	12.8	12.2	11.5	10.8	9.8	8.8	7.8	6.4	4.5	2.0														
		30	15.0	14.3	13.8	13.3	12.8	12.0	11.3	10.5	9.5	8.5	7.5	6.0	4.0																
		40	14.5	13.8	13.3	12.8	12.0	11.3	10.5	9.5	8.5	7.5	6.0	4.0																	
		50	13.8	13.0	12.5	11.8	11.0	10.3	7.5	8.3	7.0	5.5	3.5																		
		60	13.0	12.4	11.7	11.0	10.0	9.0	8.0	6.7	5.0	2.5																			
SHUT-OFF PSI:			143	134	126	117	108	100	91	82	74	65	56	48	39	30	22	4													
10SQ/SQE10C-290	1	0						14.7	14.3	13.8	13.3	12.8	12.3	11.8	11.0	10.5	9.5	7.7	3.0												
		20			15.0	14.5	14.2	13.7	13.2	12.8	12.3	11.5	10.8	10.5	9.5	8.5	7.5	4.5													
		30		15.0	14.5	14.0	13.7	13.2	12.7	12.0	11.5	10.8	10.0	9.3	8.3	7.2	5.8	1.5													
		40	15.0	14.5	14.0	13.7	13.2	12.5	12.0	11.5	10.8	10.0	9.3	8.3	7.3	5.8	4.0														
		50	15.0	14.5	14.0	13.0	12.5	12.0	11.2	10.5	9.8	9.0	8.0	7.0	5.5	3.5	1.0														
		60	13.8	13.3	12.8	12.3	11.8	11.0	10.5	9.6	8.8	7.7	6.5	5.0	3.0																
SHUT-OFF PSI:			173	165	156	147	139	130	121	113	104	95	87	78	69	61	52	35	7												
10SQ/SQE10C-330	1	0						14.7	14.4	14.0	13.5	13.0	12.7	12.2	11.6	11.0	9.8	7.2	3.0												
		20			15.0	14.7	14.3	13.8	13.5	13.0	12.5	12.0	11.5	10.8	10.3	9.5	8.0	4.5													
		30			15.0	14.5	14.2	13.8	13.3	12.8	12.5	11.8	11.3	10.8	10.2	9.5	8.8	6.8	2.2												
		40		15.0	14.6	14.2	13.8	13.4	12.8	12.4	12.0	11.4	10.8	10.2	9.5	8.7	7.8	5.5													
		50	14.8	14.5	14.0	13.7	13.2	12.7	12.2	11.7	11.2	10.5	10.0	9.3	8.5	7.5	6.6	3.5													
		60	14.4	14.0	13.5	13.0	12.6	12.2	11.5	11.0	10.5	9.7	9.0	8.2	7.3	6.1	4.8	1.2													
SHUT-OFF PSI:			203	195	186	177	169	160	152	143	134	126	117	108	100	91	82	65	39	13											
10SQ/SQE15C-380	1 1/2	0						15.0	14.7	14.3	14.0	13.7	13.3	12.8	12.5	12.0	11.0	9.3	7.0	3.5											
		20				15.0	14.6	14.3	13.8	13.5	13.3	12.8	12.3	12.0	11.5	11.0	9.8	7.8	4.7												
		30			15.0	14.5	14.3	13.8	13.5	13.3	12.8	12.3	11.8	11.3	10.8	10.3	9.0	6.5	3.0												
		40		14.8	14.5	14.3	13.8	13.5	13.0	12.7	12.3	11.8	11.3	10.8	10.3	9.8	8.3	5.5	1.0												
		50	14.8	14.5	14.1	13.7	13.3	13.0	12.5	12.2	11.7	11.2	10.7	10.2	9.5	8.8	7.2	4.0													
		60	14.7	14.4	14.0	13.7	13.3	13.0	12.5	12.0	11.5	11.0	10.5	10.0	9.4	8.7	8.0	6.0	2.0												
SHUT-OFF PSI:			234	225	216	208	199	191	182	173	165	156	147	138	130	121	113	95	69	43	30										

## 15 SQ/SQE

### SELECTION CHARTS

FLOW RANGE  
(4 TO 20 GPM)

PUMP OUTLET  
1 1/4" NPT

(Ratings are in GALLONS PER MINUTE-GPM)

		DEPTH TO PUMPING WATER LEVEL (LIFT) IN FEET																											
PUMP MODEL	HP	PSI	20	40	60	80	100	120	140	160	180	200	220	240	260	280	300	340	400	460	520	600	700	800	900	1000	1100		
15SQ/SQE03A-70	1/3	0		19.5	16.5	13	8.5																						
		20	15.5	12	7																								
		30	11	5																									
		40	5																										
		50																											
		60																											
SHUT-OFF PSI:			41	32	24	15	7																						
15SQ/SQE05A-110	1/2	0			19.5	17.5	16	13.5	11	7.5																			
		20	19	17.5	15.5	13	10.5	6.5																					
		30	17	14.5	12.5	9.5																							
		40	14.5	12.5	9.5																								
		50	11.5	8.5																									
		60	7.5																										
SHUT-OFF PSI:			65	56	48	39	30	22	13	4																			
15SQ/SQE05B-150	1/2	0				19	18	17	15.5	14	12	10	7																
		20		19	18	16.5	15	13.5	11.5	8.5	6																		
		30	19	18	16.5	15	13	11	8.5	4.5																			
		40	17.5	16.5	15	13	11	8.5	4.5																				
		50	16.5	14.5	12.5	10.5	7.5	3																					
		60	14	12	10	7																							
SHUT-OFF PSI:			95	87	78	69	61	52	43	35	26	17	7																
15SQ/SQE07B-180	3/4	0					19.5	18.5	17.5	16.5	15.5	14	12.5	11	9	6.5													
		20		20	19	18	17	16.5	15	13.5	12.5	10.5	8.5	5.5															
		30	20	19	18	17	16	14.5	13.5	12	10	8																	
		40	19	18	17	16	14.5	13.5	12	10	8																		
		50	17.5	17	15.5	14.5	13	11.5	9.5	7																			
		60	16.5	15.5	14	12.5	11	9	6.5																				
SHUT-OFF PSI:			117	108	100	91	82	74	65	56	48	39	30	22	15	4													
15SQ/SQE10C-220	1	0						19.5	18.5	17.5	17	16	15	14	13	11.5	10	6											
		20			20	19	18.5	17.5	16.5	15.5	14.5	13.5	12.5	11	9.5	8	5.5												
		30		20	19	18.5	17.5	16.5	15.5	14.5	13.5	12.5	11	9.5	7.5	4													
		40	20	19	18.5	17.5	16.5	15.5	14.5	13.5	12.5	11	9.5	7.5	4														
		50	19	18	17	16	15	14	13	12	10.5	9	6.5																
		60	18	17	16	15	14	13	11.5	10	8.5	6																	
SHUT-OFF PSI:			145	136	128	119	110	102	93	84	76	67	58	50	41	32	24	6											
15SQ/SQE10C-250	1	0							20	19.5	18	17.5	16.5	15.5	15	14	13	11	5.5										
		20				20	19.5	18.5	18	17	16.5	15.5	15	14	13	11.5	10.5	6.5											
		30			19.5	19	18.5	18	17	16	15.5	14.5	13.5	12.5	11.5	10.5	9	4											
		40		20	19	18.5	18	17	16.5	15.5	14.5	13.5	12.5	11.5	10.5	9	7												
		50	19.5	19	18.5	17.5	17	16	15	14.5	13.5	12.5	11	10	8.5	6.5													
		60	19	18	17.5	17	16	15	14	13	12	11	9.5	8	6														
SHUT-OFF PSI:			171	162	154	145	136	128	119	110	102	93	84	76	67	58	50	32	6										
15SQ/SQE15C-290	1 1/2	0								20	19.5	18.5	18	17.5	17	16.5	15.5	15	13.5	10.5	5.5								
		20					20	19	18.5	18	17.5	17	16	15.5	14.5	14	13	11	7										
		30					19.5	19	18.5	18	17.5	16.5	16	15.5	14.5	13.5	13	12	8.5										
		40			19.5	19	18.5	18	17.5	16.5	16	15.5	14.5	14	13	12	11	8.5											
		50	20	19.5	19	18.5	17.5	17	16.5	16	15	14.5	13.5	12.5	11.5	10.5	9.5	6											
		60	19.5	18.5	18	17.5	17	16.5	15.5	15	14	13.5	12.5	11.5	10.5	9	7.5												
SHUT-OFF PSI:			197	188	180	171	162	154	145	136	128	119	110	102	93	84	76	58	32	6									

**22 SQ/SQE**

**SELECTION CHARTS**

(Ratings are in GALLONS PER MINUTE-GPM)

FLOW RANGE  
(7 TO 33 GPM)

PUMP OUTLET  
1 1/2" NPT

PUMP MODEL		HP	PSI	20	40	60	80	100	120	140	160	180	200	220	240	260	280	300	340	400	460	520	600	700	800	900	1000	1100			
22SQ/SQE03A-40	1/3	0	31.5	23																											
		20																													
		30																													
		40																													
		50																													
		60																													
SHUT-OFF PSI:			17	7																											
22SQ/SQE05A-80	1/2	0		31.5	27.5	22.5	19.5																								
		20	26.5	21	11																										
		30	19.5	6.5																											
		40	6.5																												
		50																													
		60																													
SHUT-OFF PSI:			41	32	24	15	7																								
22SQ/SQE05B-120	1/2	0		33.0	31.0	28.5	25.5	22	17	7																					
		20	30.5	28	21	15	3																								
		30	27	24	20	13																									
		40	24	20	13																										
		50	18.5	10																											
		60	17																												
SHUT-OFF PSI:			65	56	48	39	30	22	13	4																					
22SQ/SQE07B-160	3/4	0			32	30.5	28.5	26.5	24	21	17.5	12	3																		
		20	32	31.5	28	26	23.5	20.5	16.5	10.5																					
		30	29.5	27.5	25.5	22.5	19.5	15	8.5																						
		40	27.5	25.5	22.5	19.5	15.0	8.5																							
		50	24.5	22	18.5	14	6																								
		60	21	17.5	12	3																									
SHUT-OFF PSI:			89	80	71	63	54	45	37	28	19	11	2																		
22SQ/SQE10C-190	1	0			33	31.5	30.5	29	27.5	25.5	23.5	21	18	14.5	8																
		20	32.5	31.5	30	28.5	27	25	23	20.5	17.5	13	4																		
		30	31	29.5	28	26.5	24.5	22	20	16.5	12																				
		40	29.5	28	26.5	24.5	22	20	16.5	12																					
		50	27.5	26	24	21.5	19	15.5	1																						
		60	25.5	23.5	21	18	14	8																							
SHUT-OFF PSI:			107	99	90	81	73	64	55	47	38	29	21	12	4																
22SQ/SQE15C-220	1 1/2	0				32.5	31.5	30	29	27.5	26	24.5	23	21	18.5	15.5	11.5														
		20		32.5	31	30	28.5	27.5	25.5	24	22.5	20.5	17.5	14.5	10																
		30	32	31	29.5	28.5	27	25.5	23.5	22	19.5	17	14	9																	
		40	31	29.5	28.5	27	25.5	23.5	22.0	19.5	17	14	9																		
		50	29.5	28	26.5	25.0	23.5	21.5	19.0	16.5	12.5	6.5																			
		60	27.5	26.0	24.5	23.0	21.0	18.5	15.5	11.5																					
SHUT-OFF PSI:			130	121	113	104	95	87	78	69	61	52	43	35	26	17	9														

## 30 SQ/SQE

### SELECTION CHARTS

FLOW RANGE  
(8 TO 42 GPM)

PUMP OUTLET  
1 1/2" NPT

(Ratings are in GALLONS PER MINUTE-GPM)

PUMP MODEL	HP	PSI	DEPTH TO PUMPING WATER LEVEL (LIFT) IN FEET																										
			20	40	60	80	100	120	140	160	180	200	220	240	260	280	300	340	400	460	520	600	700	800	900	1000	1100		
30SQ/SQE05A-40	1/2	0	40.0	30.5	11.0																								
		20																											
		30																											
		40																											
		50																											
		60																											
SHUT-OFF PSI:			20	11	2																								
30SQ/SQE05B-90	1/2	0		41	36.5	31	23	9																					
		20	35.5	29	20	4																							
		30	27.5	17																									
		40	17																										
		50																											
		60																											
SHUT-OFF PSI:			48	39	30	22	13	4																					
30SQ/SQE10C-130	1	0			41.5	38.5	35.5	31.5	27.0	21.0	11.0																		
		20	40.5	37.5	34.5	30.5	25.5	19.0	8.0																				
		30	37.0	33.5	29.5	24.0	17.0	4.0																					
		40	33.5	29.5	24.0	17.0	4.0																						
		50	28.5	22.5	14.0																								
		60	21.0	11.0																									
SHUT-OFF PSI:			76	67	58	50	41	32	24	15	7																		
30SQ/SQE15C-170	1 1/2	0				41.5	39.5	37	35	32	28.5	24.5	19	11.5															
		20		41	39	36.5	34	31	27.5	23.5	17.5	9.5																	
		30	40.5	38.5	36	33	30	26.5	22	16	6																		
		40	38.5	36	33	30	26.5	22	16	6																			
		50	35.5	32.5	29.5	25.5	20.5	14	3																				
		60	32	28.5	24.5	19	11.5																						
SHUT-OFF PSI:			104	95	87	78	69	61	52	43	35	26	17	9															



FLOW RANGE: 1.5 - 8 GPM

OUTLET SIZE: 1" NPT

NOMINAL DIA. 3"

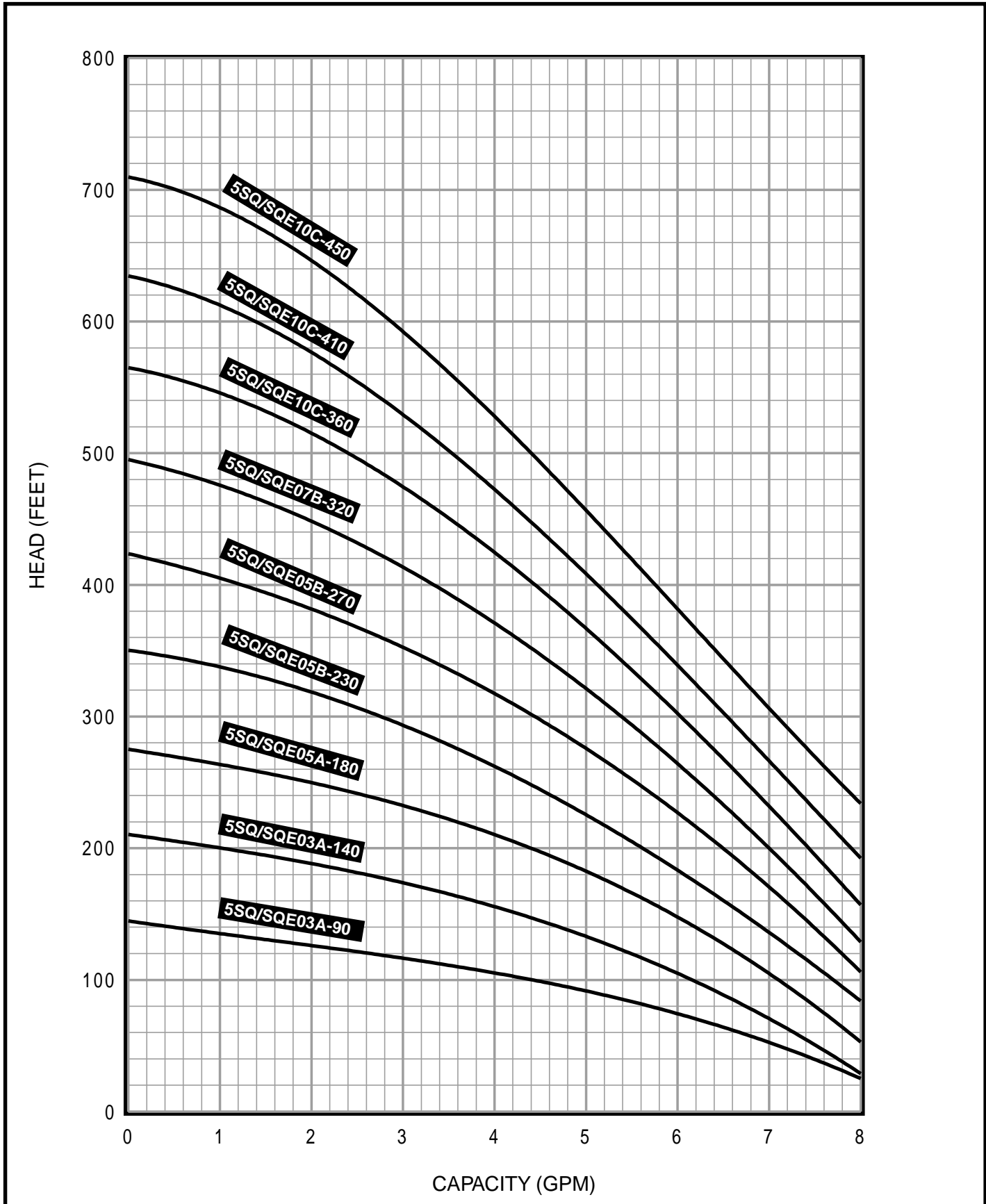

SPECIFICATIONS SUBJECT TO CHANGE WITHOUT NOTICE.

PERFORMANCE CONFORMS TO ISO 2548 ANNEX B.

## DIMENSIONS AND WEIGHTS

MODEL NO.	FIG.	HP	MOTOR SIZE	DISCH. SIZE	DIMENSIONS IN INCHES					APPROX. SHIP WT.
					A	B	C	D	E	
5SQ/SQE03A-90	A	1/3 A	3"	1" NPT	30.4	19.8	10.6	2.6	2.9	12
5SQ/SQE03A-140	A	1/3 A	3"	1" NPT	30.4	19.8	10.6	2.6	2.9	12
5SQ/SQE05A-180	A	1/2 A	3"	1" NPT	31.5	19.8	11.6	2.6	2.9	12
5SQ/SQE05B-230	A	1/2 B	3"	1" NPT	33.6	19.8	13.7	2.6	2.9	13
5SQ/SQE05B-270	A	1/2 B	3"	1" NPT	33.6	19.8	13.7	2.6	2.9	13
5SQ/SQE07B-320	A	3/4 B	3"	1" NPT	34.6	19.8	14.8	2.6	2.9	13
5SQ/SQE10C-360	A	1 C	3"	1" NPT	38.2	21.3	16.9	2.6	2.9	16
5SQ/SQE10C-410	A	1 C	3"	1" NPT	38.2	21.3	16.9	2.6	2.9	16
5SQ/SQE10C-450	A	1 C	3"	1" NPT	39.3	21.3	18.0	2.6	2.9	16

NOTES: All models suitable for use in 3" wells, unless otherwise noted.  
Weights include pump end with motor in lbs.

## MATERIALS OF CONSTRUCTION

COMPONENT	SPLINED SHAFT
Valve Casing	Polyamide
Discharge Chamber	304 Stainless Steel
Valve Guide	Polyamide
Valve Spring	316LN Stainless Steel
Valve Cone	Polyamide
Valve Seat	NBR Rubber
O-ring	NBR Rubber
Lock ring	310 Stainless Steel
Top Bearing	NBR Rubber
Top Chamber	Polyamide
Guide Vanes	Polyamide
Impeller	Polyamide w/tungsten carbide bearings
Bottom Chamber	Polyamide
Neck Ring	Polyamide
Bearing	Ceramic
Suction Interconnector	Polyamide
Ring	304 Stainless Steel
Pump Sleeve	304 Stainless Steel
Cone for pressure equalization	Polyamide
Spacer	Polyamide
Sand Trap	316 Stainless Steel
Shaft w/coupling	304 Stainless Steel
Cable Guard	304 Stainless Steel

NOTES: Specifications subject to change without notice.

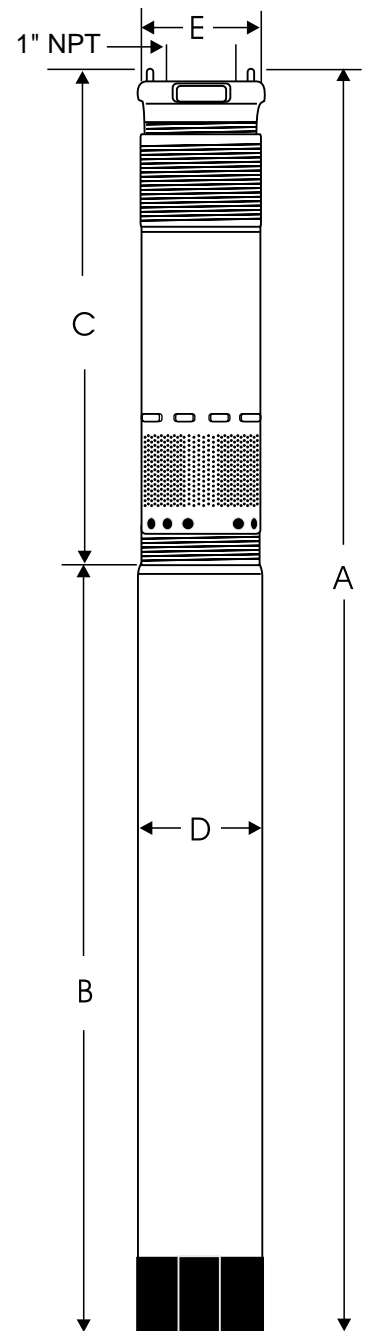
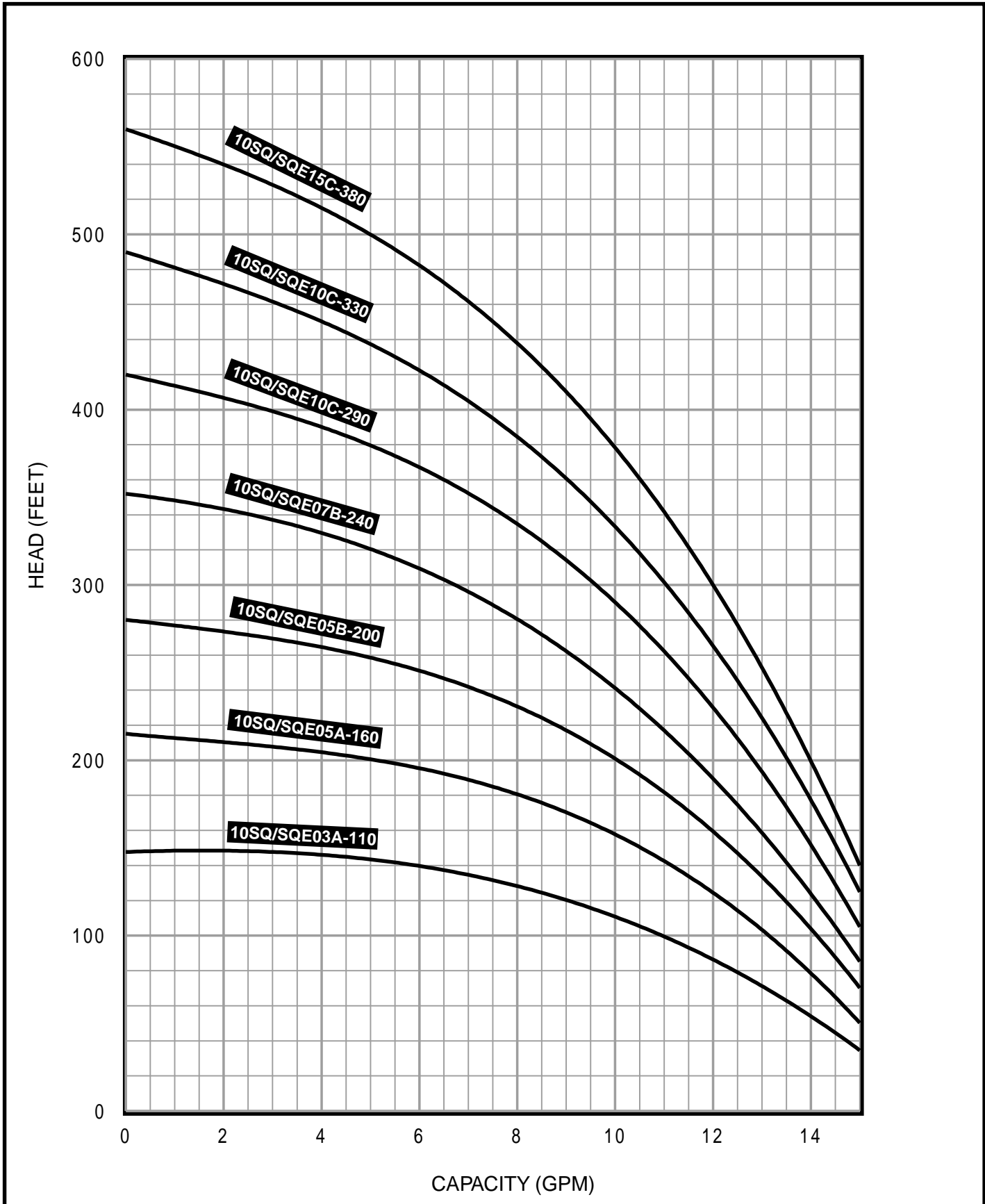

Fig. A

FLOW RANGE: 3 - 15 GPM

OUTLET SIZE: 1 1/4" NPT

NOMINAL DIA. 3"



SPECIFICATIONS SUBJECT TO CHANGE WITHOUT NOTICE.

PERFORMANCE CONFORMS TO ISO 2548 ANNEX B.



## DIMENSIONS AND WEIGHTS

MODEL NO.	FIG.	HP	MOTOR SIZE	DISCH. SIZE	DIMENSIONS IN INCHES					APPROX. SHIP WT.
					A	B	C	D	E	
10SQ/SQE03A-110	A	1/3 A	3"	1 1/4" NPT	30.4	19.8	10.6	2.6	2.9	12
10SQ/SQE05A-160	A	1/2 A	3"	1 1/4" NPT	30.4	19.8	10.6	2.6	2.9	12
10SQ/SQE05B-200	A	1/2 B	3"	1 1/4" NPT	31.5	19.8	11.6	2.6	2.9	13
10SQ/SQE07B-240	A	3/4 B	3"	1 1/4" NPT	33.6	19.8	13.7	2.6	2.9	13
10SQ/SQE10C-290	A	1 C	3"	1 1/4" NPT	35.0	21.3	13.7	2.6	2.9	16
10SQ/SQE10C-330	A	1 C	3"	1 1/4" NPT	36.1	21.3	14.8	2.6	2.9	16
10SQ/SQE15C-380	A	1 1/2 C	3"	1 1/4" NPT	38.2	21.3	16.9	2.6	2.9	16

NOTES: All models suitable for use in 3" wells, unless otherwise noted.  
Weights include pump end with motor in lbs.

## MATERIALS OF CONSTRUCTION

COMPONENT	SPLINED SHAFT
Valve Casing	Polyamide
Discharge Chamber	304 Stainless Steel
Valve Guide	Polyamide
Valve Spring	316LN Stainless Steel
Valve Cone	Polyamide
Valve Seat	NBR Rubber
O-ring	NBR Rubber
Lock ring	310 Stainless Steel
Top Bearing	NBR Rubber
Top Chamber	Polyamide
Guide Vanes	Polyamide
Impeller	Polyamide w/tungsten carbide bearings
Bottom Chamber	Polyamide
Neck Ring	Polyamide
Bearing	Ceramic
Suction Interconnector	Polyamide
Ring	304 Stainless Steel
Pump Sleeve	304 Stainless Steel
Cone for pressure equalization	Polyamide
Spacer	Polyamide
Sand Trap	316 Stainless Steel
Shaft w/coupling	304 Stainless Steel
Cable Guard	304 Stainless Steel

NOTES: Specifications subject to change without notice.

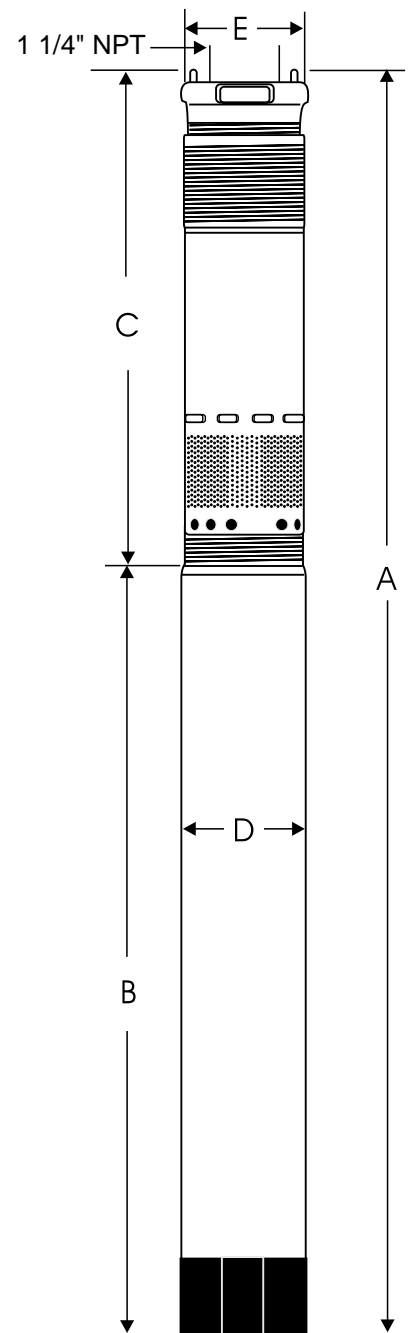
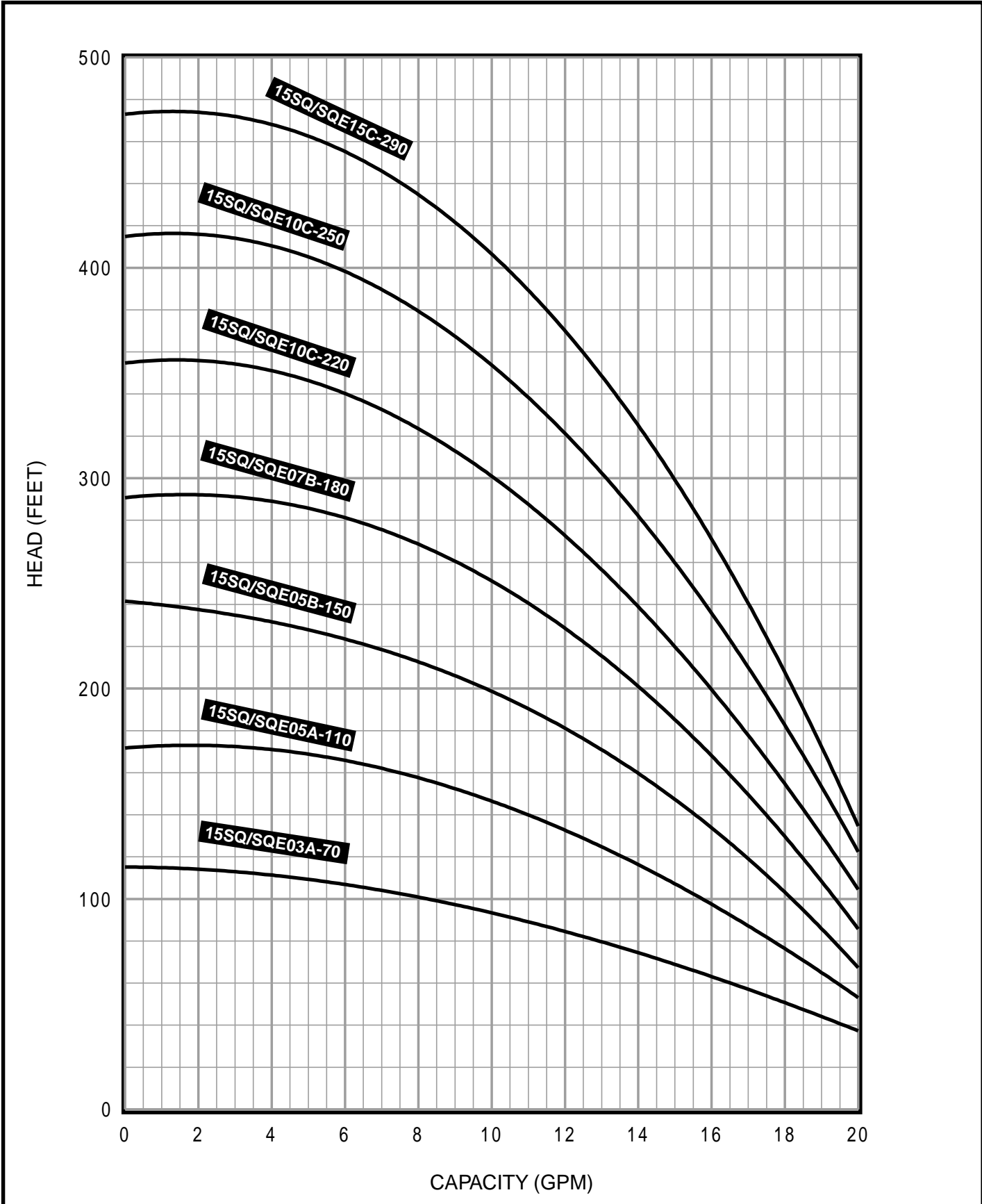

Fig. A

FLOW RANGE: 4 - 20 GPM

OUTLET SIZE: 1 1/4" NPT

NOMINAL DIA. 3"



SPECIFICATIONS SUBJECT TO CHANGE WITHOUT NOTICE.

PERFORMANCE CONFORMS TO ISO 2548 ANNEX B.

## DIMENSIONS AND WEIGHTS

MODEL NO.	FIG.	HP	MOTOR SIZE	DISCH. SIZE	DIMENSIONS IN INCHES					APPROX. SHIP WT.
					A	B	C	D	E	
15SQ/SQE03A-70	A	1/3 A	3"	1 1/4" NPT	30.4	19.8	10.6	2.6	2.9	12
15SQ/SQE05A-110	A	1/2 A	3"	1 1/4" NPT	30.4	19.8	10.6	2.6	2.9	12
15SQ/SQE05B-150	A	1/2 B	3"	1 1/4" NPT	31.5	19.8	11.6	2.6	2.9	13
15SQ/SQE07B-180	A	3/4 B	3"	1 1/4" NPT	33.6	19.8	13.7	2.6	2.9	13
15SQ/SQE10C-220	A	1 C	3"	1 1/4" NPT	35.0	21.3	13.7	2.6	2.9	16
15SQ/SQE10C-250	A	1 C	3"	1 1/4" NPT	36.1	21.3	14.8	2.6	2.9	16
15SQ/SQE15C-290	A	1 1/2 C	3"	1 1/4" NPT	38.2	21.3	16.9	2.6	2.9	16

NOTES: All models suitable for use in 3" wells, unless otherwise noted.  
Weights include pump end with motor in lbs.

## MATERIALS OF CONSTRUCTION

COMPONENT	SPLINED SHAFT
Valve Casing	Polyamide
Discharge Chamber	304 Stainless Steel
Valve Guide	Polyamide
Valve Spring	316LN Stainless Steel
Valve Cone	Polyamide
Valve Seat	NBR Rubber
O-ring	NBR Rubber
Lock ring	310 Stainless Steel
Top Bearing	NBR Rubber
Top Chamber	Polyamide
Guide Vanes	Polyamide
Impeller	Polyamide w/tungsten carbide bearings
Bottom Chamber	Polyamide
Neck Ring	Polyamide
Bearing	Ceramic
Suction Interconnector	Polyamide
Ring	304 Stainless Steel
Pump Sleeve	304 Stainless Steel
Cone for pressure equalization	Polyamide
Spacer	Polyamide
Sand Trap	316 Stainless Steel
Shaft w/coupling	304 Stainless Steel
Cable Guard	304 Stainless Steel

NOTES: Specifications subject to change without notice.

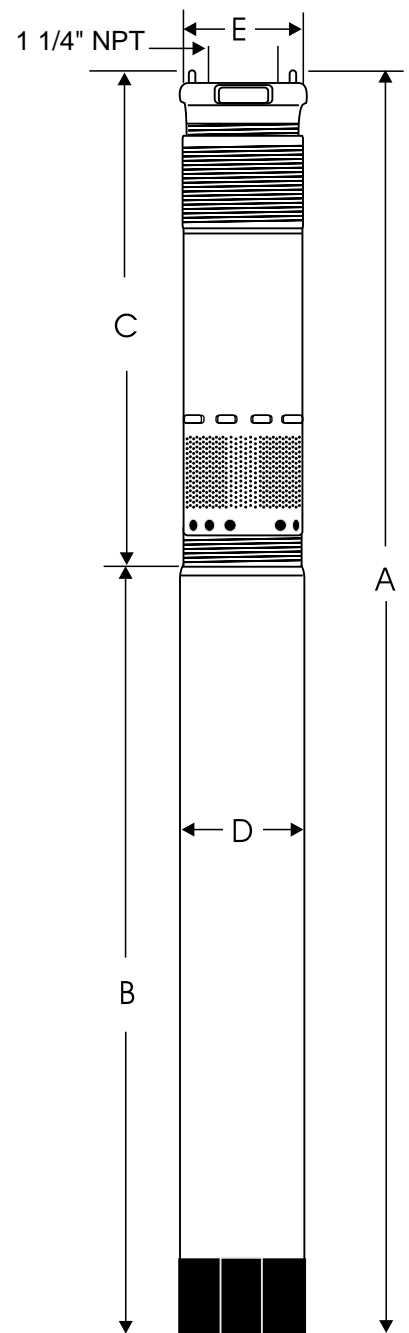
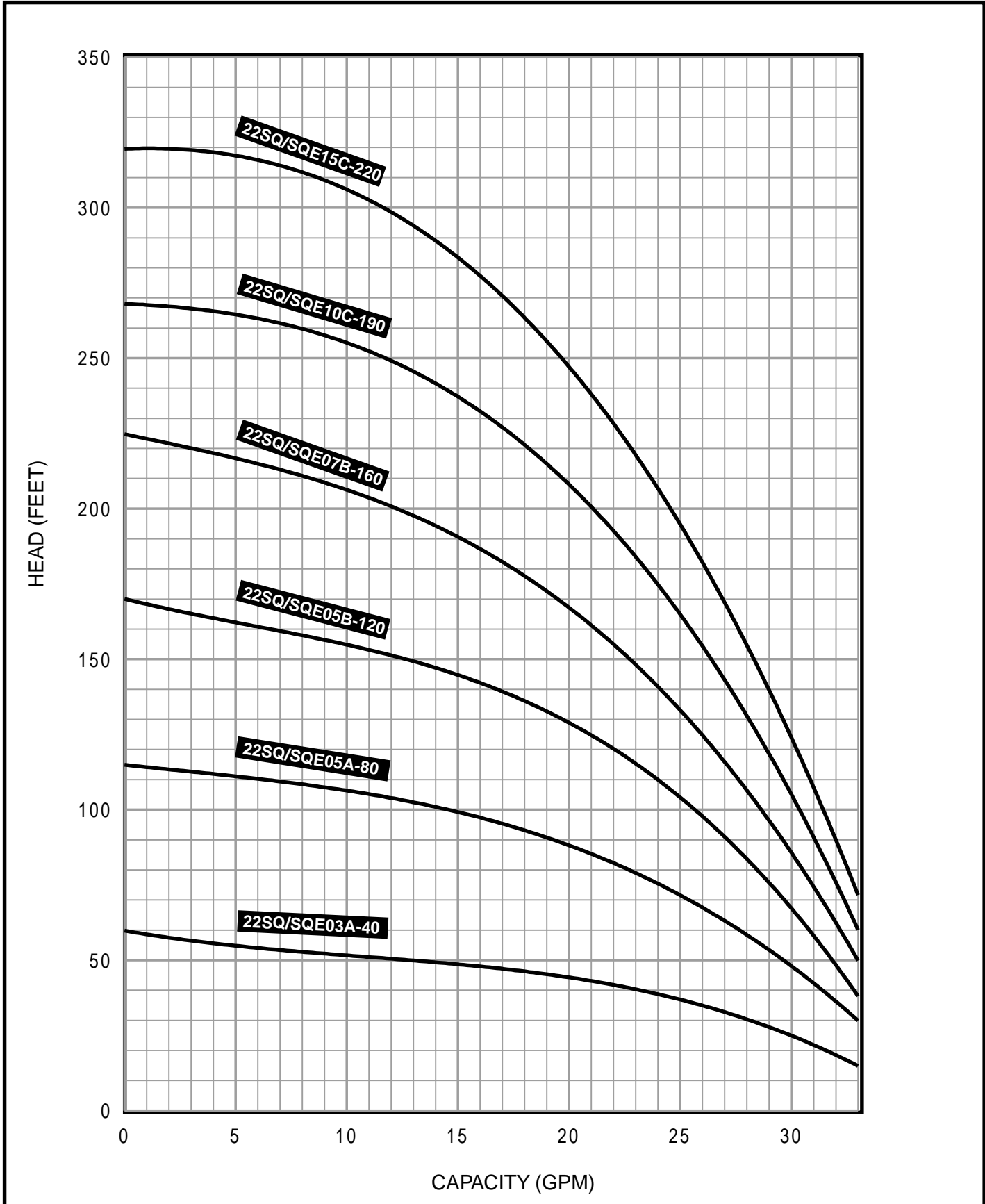

Fig. A

FLOW RANGE: 7 - 33 GPM

OUTLET SIZE: 1 1/2" NPT

NOMINAL DIA. 3"



SPECIFICATIONS SUBJECT TO CHANGE WITHOUT NOTICE.

PERFORMANCE CONFORMS TO ISO 2548 ANNEX B.

**DIMENSIONS AND WEIGHTS**

MODEL NO.	FIG.	HP	MOTOR SIZE	DISCH. SIZE	DIMENSIONS IN INCHES					APPROX. SHIP WT.
					A	B	C	D	E	
22SQ/SQE03A-40	A	1/3 A	3"	1 1/2" NPT	30.4	19.8	10.6	2.6	2.9	12
22SQ/SQE05A-80	A	1/2 A	3"	1 1/2" NPT	30.4	19.8	10.6	2.6	2.9	12
22SQ/SQE05B-120	A	1/2 B	3"	1 1/2" NPT	31.5	19.8	11.6	2.6	2.9	13
22SQ/SQE07B-160	A	3/4 B	3"	1 1/2" NPT	33.6	19.8	13.7	2.6	2.9	13
22SQ/SQE10C-190	A	1 C	3"	1 1/2" NPT	38.2	21.3	16.9	2.6	2.9	16
22SQ/SQE15C-220	A	1 1/2 C	3"	1 1/2" NPT	38.2	21.3	16.9	2.6	2.9	16

NOTES: All models suitable for use in 3" wells, unless otherwise noted.  
Weights include pump end with motor in lbs.

**MATERIALS OF CONSTRUCTION**

COMPONENT	SPLINED SHAFT
Valve Casing	Polyamide
Discharge Chamber	304 Stainless Steel
Valve Guide	Polyamide
Valve Spring	316LN Stainless Steel
Valve Cone	Polyamide
Valve Seat	NBR Rubber
O-ring	NBR Rubber
Lock ring	310 Stainless Steel
Top Bearing	NBR Rubber
Top Chamber	Polyamide
Guide Vanes	Polyamide
Impeller	Polyamide w/tungsten carbide bearings
Bottom Chamber	Polyamide
Neck Ring	Polyamide
Bearing	Ceramic
Suction Interconnector	Polyamide
Ring	304 Stainless Steel
Pump Sleeve	304 Stainless Steel
Cone for pressure equalization	Polyamide
Spacer	Polyamide
Sand Trap	316 Stainless Steel
Shaft w/coupling	304 Stainless Steel
Cable Guard	304 Stainless Steel

NOTES: Specifications subject to change without notice.

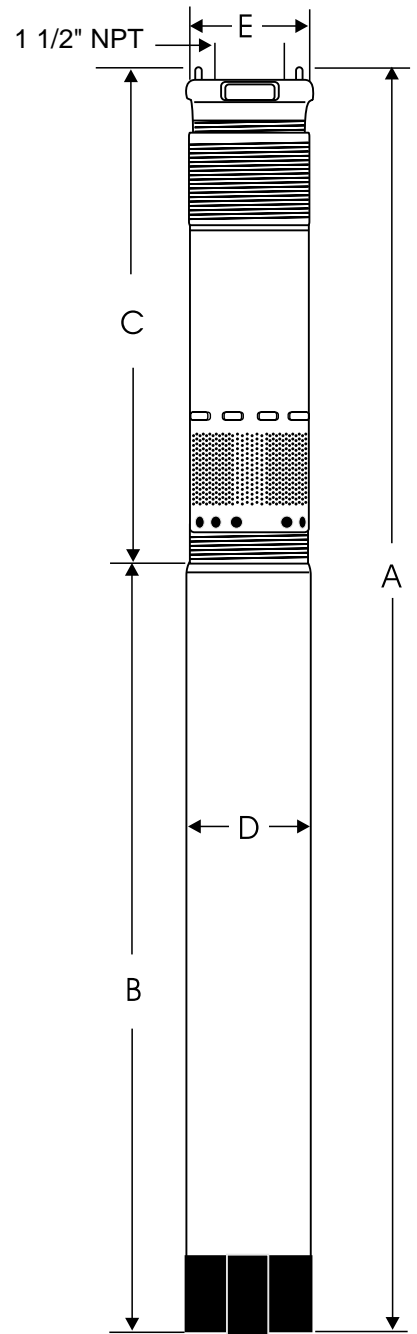
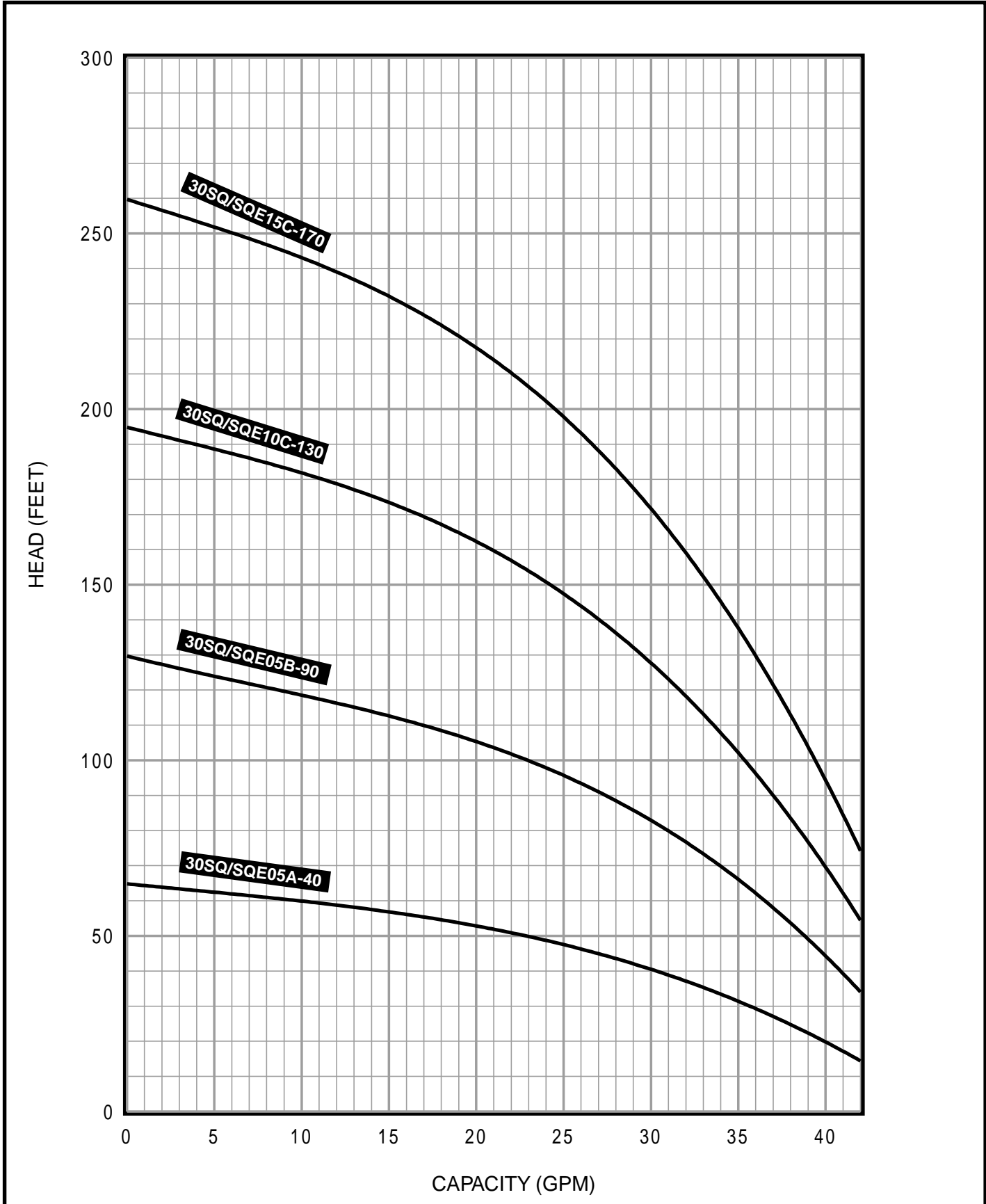

Fig. A

FLOW RANGE: 8 - 42 GPM

OUTLET SIZE: 1 1/2" NPT

NOMINAL DIA. 3"



SPECIFICATIONS SUBJECT TO CHANGE WITHOUT NOTICE.

PERFORMANCE CONFORMS TO ISO 2548 ANNEX B.

## DIMENSIONS AND WEIGHTS

MODEL NO.	FIG.	HP	MOTOR SIZE	DISCH. SIZE	DIMENSIONS IN INCHES					APPROX. SHIP WT.
					A	B	C	D	E	
30SQ/SQE05A-40	A	1/2 A	3"	1 1/2" NPT	30.4	19.8	10.6	2.6	2.9	12
30SQ/SQE05B-90	A	1/2 B	3"	1 1/2" NPT	30.4	19.8	10.6	2.6	2.9	13
30SQ/SQE10C-130	A	1 C	3"	1 1/2" NPT	35.0	21.3	13.7	2.6	2.9	13
30SQ/SQE15C-170	A	1 1/2 C	3"	1 1/2" NPT	35.0	21.3	13.7	2.6	2.9	16

NOTES: All models suitable for use in 3" wells, unless otherwise noted.  
Weights include pump end with motor in lbs.

## MATERIALS OF CONSTRUCTION

COMPONENT	SPLINED SHAFT
Valve Casing	Polyamide
Discharge Chamber	304 Stainless Steel
Valve Guide	Polyamide
Valve Spring	316LN Stainless Steel
Valve Cone	Polyamide
Valve Seat	NBR Rubber
O-ring	NBR Rubber
Lock ring	310 Stainless Steel
Top Bearing	NBR Rubber
Top Chamber	Polyamide
Guide Vanes	Polyamide
Impeller	Polyamide w/tungsten carbide bearings
Bottom Chamber	Polyamide
Neck Ring	Polyamide
Bearing	Ceramic
Suction Interconnector	Polyamide
Ring	304 Stainless Steel
Pump Sleeve	304 Stainless Steel
Cone for pressure equalization	Polyamide
Spacer	Polyamide
Sand Trap	316 Stainless Steel
Shaft w/coupling	304 Stainless Steel
Cable Guard	304 Stainless Steel

NOTES: Specifications subject to change without notice.

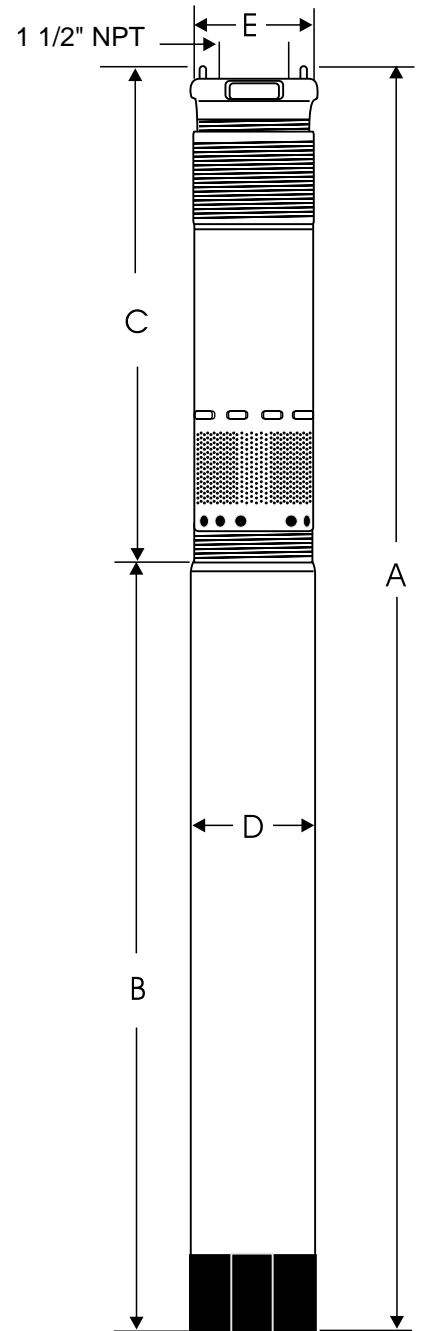

Fig. A

# **Grundfos SQ/SQE Technical Data & Accessories**



## Material specification (Pump)

Pos.	Component	Material	DIN W.-Nr.	AISI
1	Valve casing	Polyamide		
1a	Discharge chamber	Stainless steel	1.4301	304
1d	O-ring	NBR rubber		
2	Valve cone	Polyamide		
3	Valve seat	NBR rubber		
4	Top chamber	Polyamide		
4a	Empty chamber	Polyamide		
6	Top bearing	NBR rubber		
7	Neck ring	Polyamide		
7a	Lock ring	Stainless spring steel	1.4310	310
9a	Guide vanes	Polyamide		
10	Bottom chamber	Polyamide		
13	Impeller with tungsten carbide bearing	Polyamide		
14	Suction interconnector	Polyamide		
14a	Ring	Stainless steel	1.4301	304
16	Shaft with coupling	Stainless steel Sintered steel	1.4301	304
18	Cable guard	Stainless steel	1.4301	304
18a	Screws for cable guard	Stainless steel	1.4401	316
30	Cone for pressure equalisation	Polyamide		
39	Valve spring	Stainless spring steel	1.4406	
55	Pump sleeve	Stainless steel	1.4301	304
70	Valve guide	Polyamide		
85a	Spacer	Polyamide		

## Example: SQ

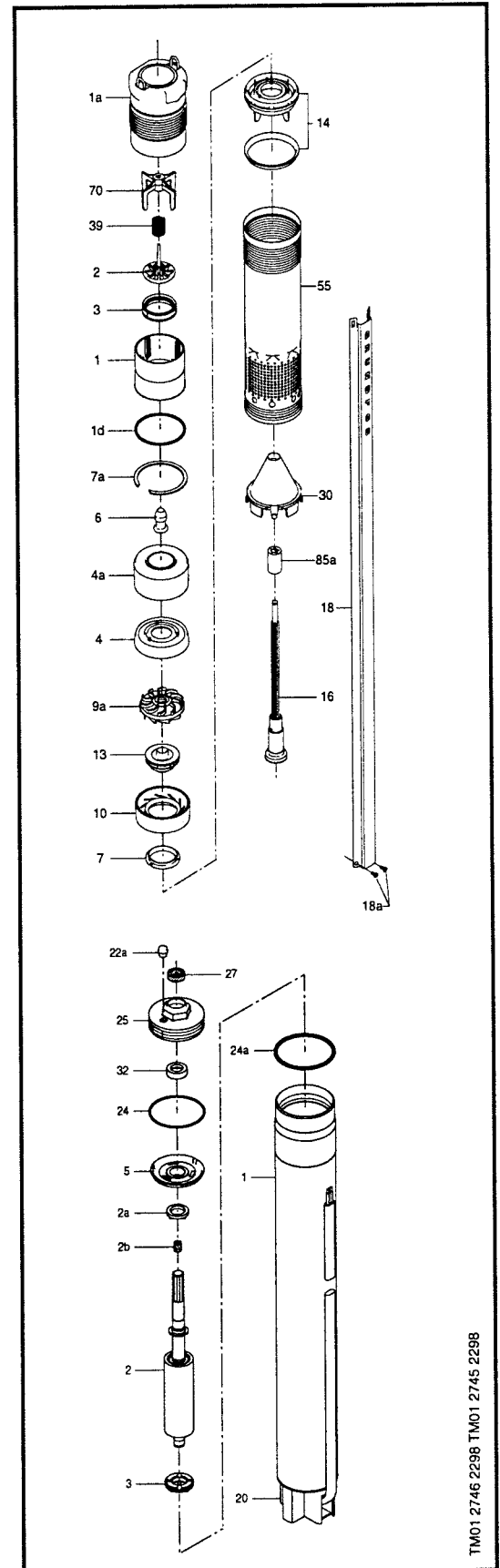

## Material specification (Motor)

Pos.	Component	Material	DIN W.-Nr.	AISI
1	Stator	Stainless steel	1.4301	304
2	Rotor	Stainless steel	1.4301	304
2a	Stop ring	PP		
2b	Filter	Polyester		
3	Thrust bearing	Carbon		
5	Radial bearing	Ceramic/tungsten carbide		
20	Motor cable with plug	EPR		
22a	Filling plug	MS 3: NBR MSE 3: FPM		
24	O-ring	FPM		
24a	O-ring	FPM		
25	Top cover	PPS		
27	Filter	Polyester		
32	Shaft seal	MS 3: NBR MSE 3: FPM		
	Motor liquid	SML-2		

# SQ/SQE Technical Data

<b>ELECTRIC</b>	
<b>Supply Voltage:</b>	1x200-240V +6%/-10%, 50/60 Hz, PE 1x100-115V +6%/-10%, 50/60 Hz, PE
<b>Operation via Generator:</b>	As a minimum, the generator output must be equal to the motor P1[KW] +10%
<b>Starting Current:</b>	The motor starting current is equal to the highest value stated on the motor nameplate
<b>Starting:</b>	Soft-start
<b>Run-up Time:</b>	Maximum : 2 seconds
<b>Motor Protection:</b>	The motor is protected against: Dry running, overvoltage, undervoltage, overload, overtemperature
<b>Power Factor:</b>	PF= 1
<b>Service Factor:</b>	0.33-0.50A[Hp]-1.75 at 115V/230V 0.50-0.75A[Hp]-1.4 at 230V 1.0 -1.5C[Hp] -1.15 at 230V
<b>Motor Cable:</b>	3 Wire, 14 AWG XLPE
<b>Motor Liquid:</b>	Type SML 2
<b>pH Values:</b>	SQ and SQE: 5 to 9
<b>Liquid Temperature:</b>	The temperature of the pumped liquid must not exceed 104°F.
<b>Note: if liquids with a viscosity higher than that of water are to be pumped, please contact GRUNDFOS</b>	
<b>PIPING CONNECTION</b>	
<b>Discharge Port:</b>	5SQ/SQE- 1"NPT 10-15SQ/SQE- 1 1/4" NPT 22-30SQ/SQE- 1 1/2" NPT
<b>STORAGE CONDITIONS</b>	
<b>Minimum Ambient Temperature:</b>	-4°F
<b>Maximum Ambient Temperature:</b>	+140°F
<b>Frost Protection:</b>	If the pump has to be stored after use, it must be stored on a frost-free location or it must be ensured that the motor liquid is frost-proof. The motor must be stored without being filled with motor liquid.
<b>OPERATING CONDITIONS</b>	
<b>Minimum Ambient Fluid Temperature:</b>	34°F
<b>Maximum Ambient Fluid Temperature:</b>	+104°F
<b>APPROXIMATE DIMENSIONS AND WEIGHT</b>	
<b>Motor Dimensions (MS 3 &amp; MSE 3):</b>	
0.33-0.50A[Hp]	20.9" length x 2.68" diameter
0.50-0.75B[Hp]	20.9" length x 2.68" diameter
1.0-1.5C[Hp]	22.3" length x 2.68" diameter
<b>Motor Weights (MS 3 &amp; MSE 3):</b>	
0.33-0.50A[Hp]	6.0 lbs
0.50-0.75B[Hp]	7.1 lbs
1.0-1.5C[Hp]	8.2 lbs
<b>Pump End Dimensions:</b>	
Pump Diameter:	2.68"
Pump Diameter, incl. cable guard:	2.91"
<b>Pump End Dimensions(min. and max.):</b>	
5SQ/SQE	10.6" to 18.0"
10SQ/SQE	10.6" to 16.9"
15SQ/SQE	10.6" to 16.9"
22SQ/SQE	10.6" to 16.9"
30SQ/SQE	10.6" to 13.7"
<b>Pump End Weights (min. and max.):</b>	
All SQ/SQE Models	2.2 lbs to 3.5 lbs
<b>Well Diameter (minimum):</b>	3"
<b>Installation Depth (Maximum):</b>	500 feet, below static water level

## CU300 Status Box

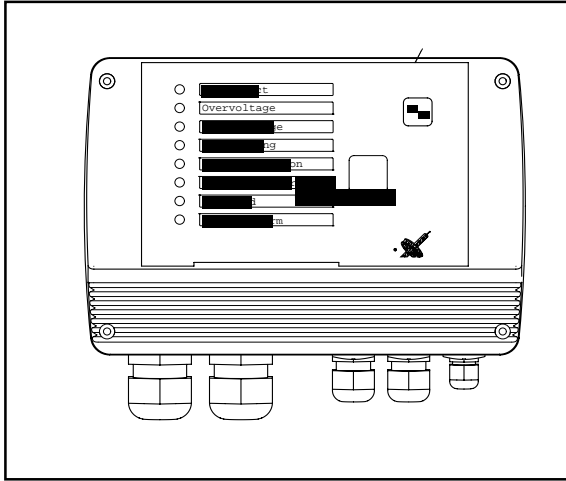

Description	Product no.
CU300 Status Box	96422776

## Constant Pressure Kit

Description	Product no.
5-15 SQE (Includes CU300, pressure transducer & .5 gpm flow switch)	96022968
22-30 SQE (Includes CU300, pressure transducer & 1 gpm flow switch)	96022971

## Flow Switch

Description	Product no.
5-15 SQE .5 GPM	96022967
22-30 SQE 1 GPM	96022970

## Pressure Transducer

Description	Product no.
Pressure Transducer 0-90 psi (0-6 bar)	96026030

## 3" Well Seal

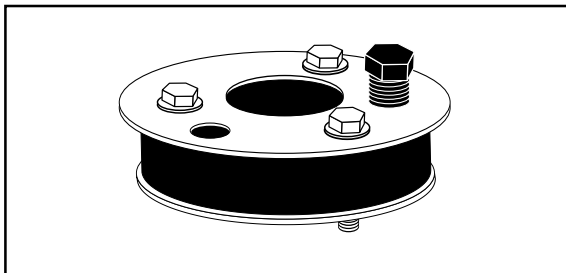

Description	Product no.
3" Sanitary Well Seal	1B5102

# SQ/SQE Accessories

## R100 remote control

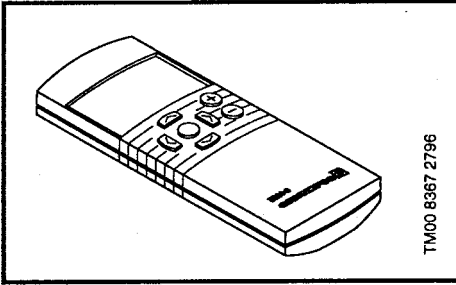

Description	Product no.
The R100 is used for wireless infrared communication with the CU300	6253333

## Printer

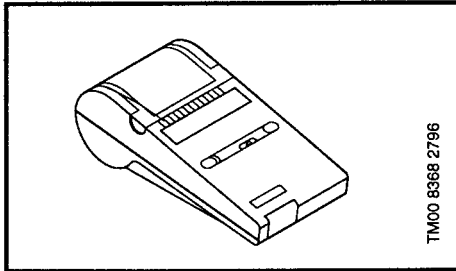

Description	Product no.
Printer for R100, infrared communication	620480
Type: Hewlett Packard, HP 82240B	
Paper Roll	620481

## Potentiometer

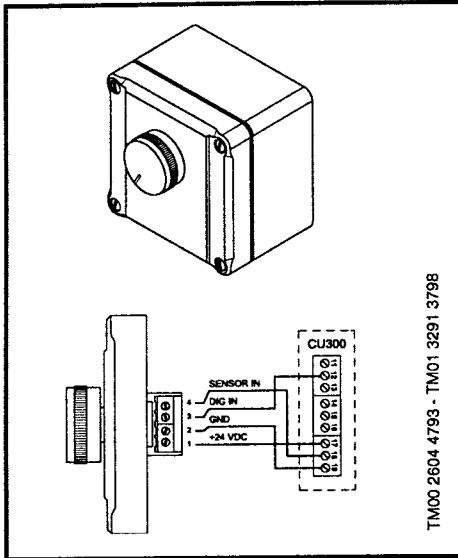

Description	Version	Product no.
External potentiometer with cabinet for wall mounting. Screened cables, 4-wire cable, max. length of cable: 100m	Grundfos potentiometer, SPP1 Enclosure class: IP 55	655468

## SQE - Speed calculation software

Description	Product no.
Speed calculation program (Windows95) including: <ul style="list-style-type: none"> <li>• PC Tool SQE speed calculation, two diskettes</li> <li>• Operating manual</li> </ul>	96426840

## SQ/SQE - Flow sleeve

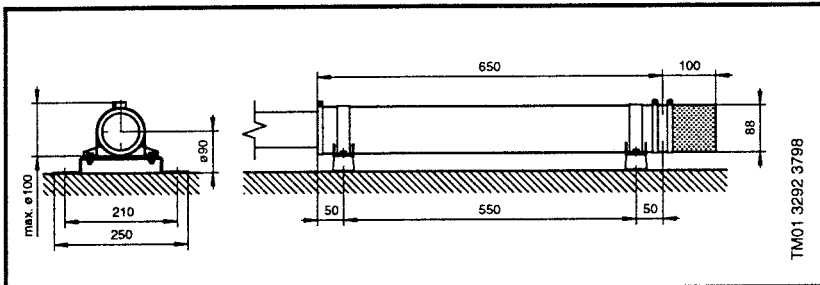

Description	Product no.
Flow Sleeve Complete	96037505







**GRUNDFOS**<sup>®</sup>



*Leaders in Pump Technology*

**Grundfos Pumps Corporation** • 3131 N. Business Park Avenue • Fresno, CA 93727

**Customer Service Centers:** Allentown, PA • Fresno, CA

**Phone:** (559) 292-8000 • **Fax:** (559) 291-1357

**Canada:** Oakville, Ontario • **Mexico:** Apodaca, N.L.

*Visit our website at [www.us.grundfos.com](http://www.us.grundfos.com)*



L-SQ-TL-002	Rev.7/99
PRINTED IN USA	