



Technical Handbook

- [TOC](#)
- [CM4 Overview](#)
- [Controls and Indicators](#)
- [Installation](#)
- [Basic Operation](#)
- [Calibration Mode Funct.](#)
- [Review Menu Functions](#)
- [Setup Menu](#)
- [Service Menu](#)
- [Maintenance](#)
- [Options](#)
- [Specifications](#)
- [Fault Listing](#)
- [Detectable Gases](#)
- [Printer Options](#)
- [Serial Comm Protocol](#)
- [Installation Drawings](#)
- [Warranty Statement](#)

Your Uptime Is Our Top Priority

Because your uptime is our top priority, Honeywell Analytics, Inc. provides you with a 24-hour Emergency Service Hotline.

During Business Hours: Honeywell Analytics, Inc. (U.S.A.)
Corporate Headquarters:

847-955-8200
(Toll-Free) 800-323-2000

www.honeywellanalytics.com

24-Hour Emergency Hotline: 847-634-2840

Record your serial number and installation date for easy reference. To save time when calling for service, please have the serial number of your instrument available.





Symbols Used on Your Instrument

Overview

Your Honeywell Analytics instrument uses several symbols to provide information. Each symbol provides a graphic representation of equivalent words. The symbols are easily recognizable in any language.

Below is a listing of symbols used on Honeywell Analytics products and a brief description of what the symbols represent. (Your instrument model might not use all of the symbols listed here.)

Symbols

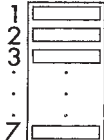
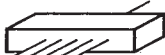
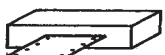
	Power Switch ON
	Power Switch OFF
	Power Indicator LED
	Locked Keypad LED
	Alarm LED
	Equipment Mounting Position in Rack
	Printer Share Box
	Printer



Caution – Refer to accompanying documents. Caution statements are used to indicate hazards or unsafe practices which could result in minor personal injury or product or property damage.



Warning – Refer to accompanying documents. Warning statements are used to indicate hazards or unsafe practices which could result in severe personal injury or death.



Caution – Risk of electrical shock



Caution – Hot Surface



Direct Current (D.C.)



Ground Terminal

EMC Considerations

Overview

Your Honeywell Analytics instrument has been designed to comply with applicable Electromagnetic Compatibility (EMC) standards at the time of manufacture. The design includes filtering, shielding and bypassing techniques. At the time of certification, simulated customer Input/Output (I/O) schemes were tested.

All methods used in your equipment for emission suppression and reduction of susceptibility are interactive. Modifications to the instrument will most likely result in increased emissions and higher vulnerability to other radiated fields.

Following the guidelines in this EMC Considerations section will ensure your instrument maintains the highest degree of EMC integrity. The guidelines listed apply only to I/O emissions and do not apply to A.C. and D.C. instrument power connections.

Cabling

At a very minimum, all cables should include a braided shield. Ideal results have been obtained with twisted pair cabling which has a foil shield surrounding each pair plus foil and 90% braid shielding around the bundle. While this yields the best results, it can be very expensive. In addition, ensure local electrical code requirements are met.

Cabling Type

The following cable parameters must be considered:

- Braid** Must have minimum 90% coverage.
- Foil** When used with braid, provides 100% coverage.

NOTE:
Do not use foil alone, it has a tendency to break.

- Twisted Pair** Provides for cancelling of magnetic fields.
- Stranded Pair** Provides the greatest surface area MDA Scientific product testing uses >90% braid with foil (around the bundle); twisted pair; stranded 24 AWG (minimum wiring for all qualification and certification testing).

Examples:

- Belden 83652 2-conductor
- Belden 83653 3-conductor
- Belden 83654 4-conductor
- Belden 83656 6-conductor

All examples are 18 AWG stranded, with 100% shield coverage.

- Shield Termination** Continuation of the shield to the cabinet earth ground is most important.

For discrete wire terminations, pigtailed to the cabinet (connector) ground should be extremely short (absolutely no greater than three inches).

For multiconductor connector terminations, only 360° shielded shells should be used.

Connectors

All qualification and certification of MDA Scientific products were achieved with high quality connectors, providing 360° shield coverage. These connectors generally had metal shells.

Failure to properly secure the connector to the equipment will result in high emission levels. Also, poorly constructed or improperly assembled connectors can be a high source of radiated noise and provide a path for external signals into the instrument.

Table of Contents

Your Uptime Is Our Top Priority.....	i	1.5.2 Power Connection.....	1-7
Symbols Used on Your Instrument	ii	1.5.3 Optional Serial Output	1-7
Overview.....	ii	1.6 Alarms.....	1-7
Symbols.....	ii	1.6.1 General and Point Gas Alarms	1-7
EMC Considerations	iii	1.6.2 Activating an Alarm.....	1-7
Overview.....	iii	1.7 Instrument Diagnostics.....	1-8
Cabling.....	iii	2 Controls and Indicators	
Cabling Type	iii	2.1 Introduction.....	2-2
Connectors	iii	2.2 Control Panel.....	2-2
1 CM4 Overview		2.2.1 Display	2-2
1.1 Introduction.....	1-2	2.2.2 LEDs and Point ID Labels.....	2-3
1.2 Sampling and Monitoring System.....	1-3	2.2.3 Keypad.....	2-3
1.2.1 Flow Connections	1-3	2.2.4 Power Indicator LED	2-3
1.2.2 Pump	1-3	2.3 Relays	2-4
1.2.3 Filters	1-3	2.4 Sample Flow Controls	2-4
1.3 Detection System.....	1-4	3 Installation	
1.3.1 Chemcassette® Carrier	1-4	3.1 Introduction.....	3-2
1.3.2 Optics and Electronics	1-4	3.1.1 Mounting Alternatives	3-2
1.3.3 Chemcassette® Detection System	1-5	3.1.2 Accessory Kit.....	3-2
1.3.4 Measuring Gases.....	1-5	3.1.3 Installation Steps	3-2
1.4 Displays and Controls.....	1-6	3.2 Components and Connections for Installation.....	3-3
1.4.1 Display	1-6	3.3 Surveying the Installation Site	3-3
1.4.2 Status and Alarm LEDs	1-6	3.3.1 Placement of the CM4	3-3
1.4.3 Keypad.....	1-6	3.3.2 Exposure to Dust and Humidity	3-3
1.4.4 Power LED	1-6	3.3.3 Sample Transport Time	3-4
1.4.5 Flow Control.....	1-6	3.3.4 Instrument Dimensions.....	3-4
1.5 Electrical Connections	1-6	3.4 Sample Locations	3-4
1.5.1 I/O Panel	1-6	3.4.1 Sample Line Particulate Filter Use.....	3-4

Table of Contents

3.4.2 Special Considerations for Positive Pressure ..	3-4
3.5 Configuring for Mounting Method.....	3-4
3.5.1 Wall Mount	3-5
3.5.2 Rack Mount Kit.....	3-6
3.5.3 Rack Mounting the CM4-P	3-7
3.5.4 Rack Enclosures	3-7
3.6 Installing Sample Lines.....	3-9
3.6.1 Sample Line Requirements for Installation ..	3-9
3.6.2 Tubing Connections	3-10
3.6.3 Sample Line Inlet Connections	3-10
3.6.4 Point Legend.....	3-10
3.7 Installing Sample Line Particulate Filters.....	3-11
3.8 Installing Pump Exhaust Line.....	3-11
3.8.1 Exhaust Line Installation Guidelines	3-11
3.8.2 Exhaust Tubing Specifications	3-11
3.9 Connecting AC Power Cord	3-11
3.10 Wiring Relays	3-12
3.10.1 Relay Contacts.....	3-12
3.10.2 Ratings	3-12
3.10.3 Wiring Guidelines.....	3-13
3.11 Wiring Optional Current Loop (4-20 mA Output)	3-13
3.12 Loading Chemcassette® Tape	3-14
3.13 Power On/Off	3-14
3.14 Installation Notice.....	3-14
3.15 Function and Cursor Keys	3-15
3.15.1 MONITOR	3-15
3.15.2 PROGRAM	3-15
3.15.3 RESET/ESCAPE	3-15

3.15.4 ENTER.....	3-15
3.15.5 CURSOR ARROW LEFT/RIGHT.....	3-15

4 Basic Operation

4.1 Introduction	4-2
4.2 Monitor Mode	4-2
4.2.1 Exiting Monitor Mode	4-3
4.2.2 Printing Time Weighted Averages (TWA) During Monitor Mode	4-3
4.2.3 Point Lock-On During Monitor Mode.....	4-3
4.2.4 Display Lock-On During Monitor Mode	4-4
4.2.5 Alarm History During Monitor	4-4
4.2.6 Fault History During Monitor Mode	4-5
4.2.7 Display Point Flows During Monitor Mode...	4-5
4.2.8 Advance Chemcassette Tape During Monitor Mode	4-5
4.3 Program Mode.....	4-5
4.4 Alarms and Faults.....	4-6
4.4.1 Alarms.....	4-6
4.4.2 Faults	4-6
4.5 Accessing Programming Functions	4-6
4.5.1 Programming by Scrolling.....	4-7
4.5.2 Programming Using Direct Numeric Entry...	4-7
4.6 CM4 Menu Structure	4-8
4.7 Keypad Locking Feature	4-9

5 Calibration Mode Functions

5.1 Introduction	5-2
5.2 Function 1.1 – Optics Verify	5-2
5.3 Function 1.2 – Manual K-Factor	5-3
5.4 Function 1.3 – Calibrate Current Loop	5-4

Table of Contents

5.4.1 Selecting the Signal Levels Manually.....	5-5	7.3 Function 3.2 – Point Parameters	7-3
5.4.2 Selecting Signal Levels – Automatic Ramping	5-5	7.3.1 Select Gas Type, Program Alarms and Set Current Loop Full Scale Values.....	7-3
5.4.3 Selecting Signal Levels – Step	5-6	7.3.2 Defining the Point ID	7-5
5.5 Function 1.4 – Tune Current Loop	5-6	7.4 Function 3.3 – Output Options	7-6
6 Review Menu Functions		7.4.1 Optional COM Port (3.3.1)	7-6
6.1 Introduction	6-2	7.4.2 Optional Printer Port (3.3.2)	7-7
6.2 Function 2.1 – Alarm History	6-2	7.4.3 Printer Format (3.3.3)	7-8
6.2.1 Print Alarm History	6-2	7.4.4 Relay State (3.3.4)	7-9
6.2.2 Display Alarm History	6-3	7.4.5 2 mA Fault Operation (3.3.5).....	7-10
6.3 Function 2.2 – Fault History	6-4	7.4.6 Enable/Disable Duty Cycle Option (3.3.6) .	7-10
6.3.1 Print Fault History	6-4	7.5 Function 3.4 – Configuration	7-11
6.3.2 Display Fault History	6-4	7.6 Function 3.5 – Date & Time	7-12
6.4 Function 2.3 – Current TWA	6-5	7.6.2 Set Date & Time (3.5.2)	7-12
6.4.1 Print TWA.....	6-5	7.6.3 Set Display Cycle (3.5.3)	7-13
6.4.2 Display TWA.....	6-6	7.6.4 Set TWA Printout Time (3.5.4)	7-13
6.5 Function 2.4 – Last Power-Down.....	6-6	7.6.5 Set Idle Time (3.5.5)	7-14
6.5.1 Print Last Power-Down	6-6	7.6.6 Set Duty Cycle (optional) (3.5.6).....	7-14
6.5.2 Display Last Power-Down	6-7	7.7 Function 3.6 – Access Setup	7-14
6.6 Function 2.5 – Customer Data	6-7	7.7.1 Set Key Lock Code	7-15
6.6.1 Print Customer Data	6-7	7.8 Function 3.7 – Maintenance Set-Up	7-16
6.6.2 Display Customer Data	6-7	7.8.1 Chemcassette® Counter (3.7.1)	7-16
6.7 Function 2.6 – Print Configuration.....	6-8	7.8.2 Internal Filter Timer (3.7.2)	7-16
6.8 Function 2.7 – Instrument Serial Number.....	6-8	7.8.3 External Filter Timer (3.7.3)	7-17
6.9 Function 2.8 – Print Menu	6-10	8 Service Menu	
7 Setup Menu		8.1 Introduction	8-2
7.1 Introduction	7-2	8.2 Function 4.1 – Relay/LED Test	8-2
7.1.1 Enabling/Disabling the Keypad	7-2	8.3 Alarm Tests.....	8-3
7.2 Function 3.1 – Point Enable	7-3		

Table of Contents

8.3.1 Function 4.2.1-Alarm Indicator Test	8-3
8.3.2 Function 4.2.2-Simulated Alarm Test	8-3
8.3.3 Function 4.2.3-Optics Alarm Test	8-5
8.4 Function 4.3 – Diagnostics	8-7
8.5 Function 4.4 – Reset System	8-8
8.6 Function 4.5 – Load Chemcassette®/Filter Change	8-8
8.7 Function 4.6 – Set Flow	8-11
8.8 Function 4.7 – MDA Service	8-12
8.9 Function 4.8 – Pump Limits	8-12
8.9.1 Operation	8-12
8.9.2 Set-up	8-12
8.10 Function 4.9 – Reboot	8-13
9 Maintenance	9-2
9.1 Introduction	9-2
9.2 Chemcassette® Maintenance	9-2
9.2.1 Remove Carrier	9-2
9.2.2 Verify Optics	9-4
9.2.3 Loading the Carrier	9-5
9.2.4 Installing the Chemcassette®	9-6
9.2.5 Checking Flowrates	9-7
9.3 Filter Maintenance	9-8
9.3.1 CM4 Internal Filter Replacement Procedure	9-9
9.3.2 Sample Line Particulate Filter	9-10
9.3.3 CM4-P Filter Maintenance	9-10
9.4 Fuse Replacement	9-11
9.4.1 AC Line Fuse	9-11
9.5 Cleaning the Chemcassette® Optics	9-12
9.6 Installing Microtube Assembly	9-13

10 Options	10-2
10.1 Communications Options	10-2
10.1.1 Serial Communications	10-2
10.1.2 Printers	10-2
10.2 Remote Alarm Reset Option	10-2
10.2.1 How it Works	10-2
10.2.2 Wiring Considerations	10-3
10.2.3 Using an External Power Supply	10-3
10.2.4 Using the CM4 Monitor's Internal Power Supply	10-3
10.3 Sample Line Integrity Option	10-5
A Specifications	A-2
A.1 Introduction	A-2
A.2 Filter Compatibility	A-2
A.3 General Specifications	A-3
A.3.1 CM4	A-3
A.3.2 CM4-P	A-3
A.4 Transport Times	A-4
B Fault Listing	B-2
B.1 Fault Codes	B-2
B.2 Leak Check Procedure	B-8
C Chemcassette® Detectable Gases	C-2
D Printer Options	D-2
D.1 Overview	D-2
D.1.1 RS-232C	D-2
D.1.2 RS-422	D-2
D.1.3 Desktop Printer	D-2
D.1.4 Enclosure Printer Kit	D-2
D.1.5 Printer Share Box	D-2

Table of Contents

<u>D.2 Jumpers</u>	<u>D-3</u>	Concentration Data Format Code	<u>E-6</u>
<u>D.3 Cabling</u>	<u>D-4</u>	<u>E.3 Protocol Command Definition</u>	<u>E-7</u>
D.3.1 EMC Considerations.....	D-4	<u>E.3.1 Status and Query Commands</u>	<u>E-7</u>
D.3.2 Cabling Diagrams	D-5	NOP - 0x28	E-7
<u>D.4 Instructions and Checklist</u>	<u>D-7</u>	Get System Information - 0x30	E-7
<u>D.5 Other Applications</u>	<u>D-9</u>	Get Unit Status - 0x31	E-8
<u>E Serial Communications Protocol</u>		Get Idle Time - 0x32	E-10
<u>E.1 Introduction</u>	<u>E-2</u>	Get Date & Time - 0x33	E-10
<u>E.1.1 Overview</u>	<u>E-2</u>	Get Maintenance Dates - 0x34	E-10
<u>E.1.2 Communication Port</u>	<u>E-2</u>	Get Point Configuration - 0x35.....	E-11
<u>E.1.3 Set up Procedure</u>	<u>E-3</u>	Get Alarm History - 0x36	E-11
<u>E.1.4 Protocol Specifics</u>	<u>E-3</u>	Get Current Point Status - 0x37.....	E-12
Data and Packets.....	E-3	Get TWA Time - 0x38.....	E-12
Checksum (Check Character).....	E-4	Get Display Cycle Time - 0x39	E-12
ACK/NAK Handshake	E-4	Get the Number of Gas Tables Available - 0x3A.....	E-13
<u>E.2 Protocol Packet Definition</u>	<u>E-5</u>	Get Printer Setup - 0x3B.....	E-13
<u>E.2.1 Packet Format</u>	<u>E-5</u>	Get Gas Table Data - 0x3C	E-13
Start Code.....	E-5	Get Fault History - 0x3D	E-14
Receiver Address.....	E-5	Get K-Factor - 0x3E	E-14
Transmitter Address	E-5	Get Pyrolyzer Temperatures - 0x42	E-15
Length.....	E-5	Get Pump Limits - 0x43	E-15
Command	E-5	Get Filter Life - 0x44	E-15
Data	E-5	Get Floating Status - 0x45.....	E-16
Checksum.....	E-5	Get One Alarm - 0x47	E-17
<u>E.2.2 Generic Data Formats</u>	<u>E-6</u>	<u>E.4 Configuration and Directive Commands</u> ..	<u>E-17</u>
Date Format.....	E-6	Set K-Factor - 0x50.....	E-17
Time Format.....	E-6	Reset Fault or Alarm - 0x51	E-18
Date/Time Examples	E-6	Set Key-Code - 0x52.....	E-18

Table of Contents

Lock Keyboard - 0x53	E-19
Set 2mA Fault Operation - 0x54.....	E-19
Start New Cycle - 0x55	E-19
Program Chemcassette Counter - 0x56	E-20
Set Printer Configuration - 0x57	E-20
Set Point Enable/Disable – 0x58.....	E-21
Set Point Configuration - 0x59	E-21
Set TWA Time - 0x5A.....	E-22
Set Display Time - 0x5B.....	E-22
Set Idle Time - 0x5C	E-22
Set Date Format - 0x5D.....	E-23
Set Date and Time - 0x5E.....	E-23
Set Relay State - 0x5F.....	E-24
End Point Lock-on - 0x60.....	E-24
Start Point Lock-on - 0x61	E-24
Save Current Configuration - 0x62	E-25
Restore Configuration - 0x63.....	E-25
Set Duty Cycle - 0x65	E-25
Set Filter - 0x66	E-26
Get Duty Cycle - 0x69.....	E-26
E.5 Operation	E-27
E.5.1 CM4 Instrument Power-up	E-27
E.5.2 Commands.....	E-27
E.5.3 Responses	E-27
E.6 Example Packets	E-27
E.7 Serial Device Applications	E-31
E.7.1 Impedance Matching	E-33
E.8 Glossary	E-34

[F Installation Drawing](#)

[G Warranty Statement](#)

[Chemcassette® Device Warranty Statement.....G-2](#)

[Chemcassette® Warranties](#)**G-2**

1 CM4 Overview

1.1 Introduction

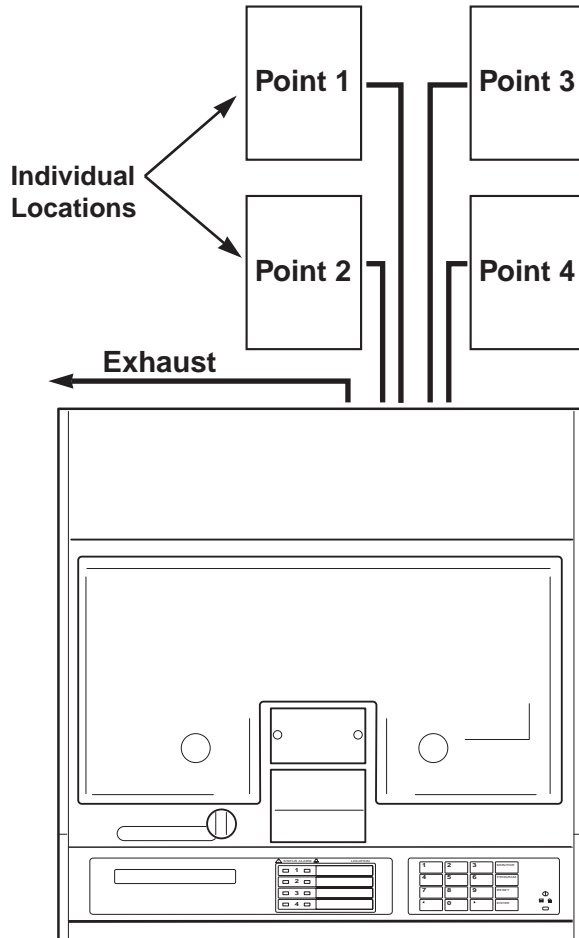

Figure 1-1: Monitoring Points

The MDA Scientific CM4 continuously monitors four locations (called *points*) for toxic gases. It responds to gases that exceed a programmed alarm level by:

- Triggering alarms and LEDs that warn of high or low concentrations
- Triggering relays to external devices
- Displaying the point number, gas type, and gas concentration
- Printing the alarm information and storing it in memory (printing requires optional printer)

The CM4 triggers relays for each individual point for two levels of gas concentrations. These programmable limits are factory-set at TLV and 2 TLV.

Each point may be up to 300 feet (90 m) from the CM4 location. This allows operators to monitor gas concentrations in an area removed from the location where gas may actually be leaking.

The CM4 provides fast response to a wide range of gases. It was designed for maximum uptime, so filters, detector tape, and even the entire chassis can be replaced quickly and easily.

The CM4's flexibility allows it to be easily configured for tabletop use, rack mounting or wall mounting. The CM4 uses MDA Scientific's patented Chemcassette[®] technology for rapid, accurate gas detection.

This section includes information on the CM4's:

- Sampling and Monitoring System ([Section 1.2](#))
- Detection System ([Section 1.3](#))
- Displays and Controls ([Section 1.4](#))
- Electrical Connections ([Section 1.5](#))
- Alarms ([Section 1.6](#))
- Instrument Diagnostics ([Section 1.7](#))

1.2 Sampling and Monitoring System

The system draws sample flow simultaneously from all four points. Two different types of sample movement are:

- Transport flow: high-velocity, large-volume air movement through the lines
- Sample flow: air admitted to the Chemcassette® detection system

The high speed of transport flow allows rapid monitoring and response time when using long lines from monitoring points to the CM4. A small portion of the transport flow is analyzed to determine concentration levels.

NOTE:

On newer style CM4 (S/N XXX-5000 and greater) and all CM4-P models, the flow controls (item 6) are located on the lower left of the front panel. An ambient air filter (item 10) is located on the lower right.

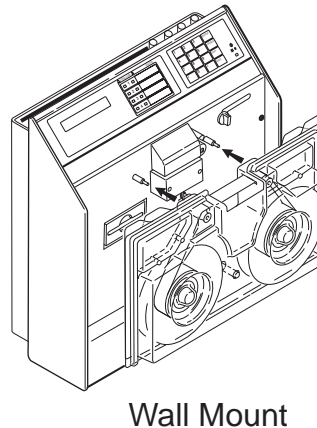
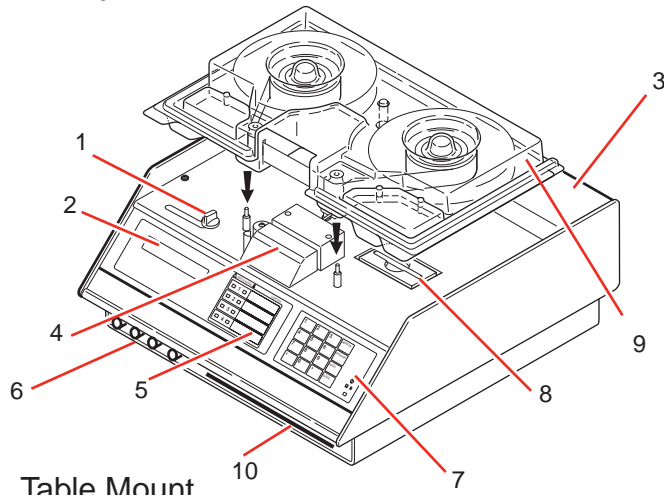

LEGEND

1. Tape load lever
2. 20-character display
3. Alarm relays
4. Detectors and electronics
5. Status and alarm LEDs
6. Flow controls
7. Keypad
8. Filter block
9. Carrier
10. Air filter

The flow system includes:

Flow connections (Manifolds)	Orifice
Pump	Valves
Filters	Transducers

1.2.1 Flow Connections

Flow connections consist of quick-connect ports on the back of the CM4. There are four inlets, one for each monitored point, and an exhaust outlet.

1.2.2 Pump

The pump provides a vacuum source for transport and sample flow during monitoring.

1.2.3 Filters

Filters protect the internal precision orifice from dust particles. Filters are located in a removable filter block on the top of the instrument. See [Section 9](#) for information about filter replacement.

Figure 1-2: CM4 Components and Controls

1.3 Detection System

The CM4 uses the patented MDA Scientific Chemcassette® detection system. Chemcassettes® sample and detect a specific gas or family of gases. The Chemcassette® detection system is included on an analyzer plate on top of the CM4. The analyzer plate:

- Retains the Chemcassette® carrier
- Manages Chemcassette® transport
- Provides optical detection of stain
- Directs sample flow through the Chemcassette®

Components of the detection system include:

- Chemcassette® carrier containing Chemcassette detection tape
- Optics and electronics for the detection system
- Chemcassette® tape transport mechanism

1.3.1 Chemcassette® Carrier

The Chemcassette® carrier can be pre-loaded with Chemcassette® tape for rapid tape change.

1.3.2 Optics and Electronics

The heart of the Chemcassette® system is an optical detection system that measures the stain that develops on the Chemcassette® tape. The CM4's unique design has four individual detectors, one for each monitoring point. See **Figure 1-3** for point stain location.

To monitor a point, the detection system detects and measures a specific gas or family of gases in the sample. The CM4 interprets the data and responds appropriately. See [Section 3.4](#) for instructions on determining sample locations and [Section 3.6](#) for information on installing sample lines.

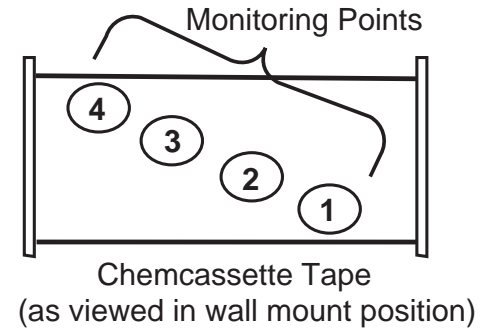
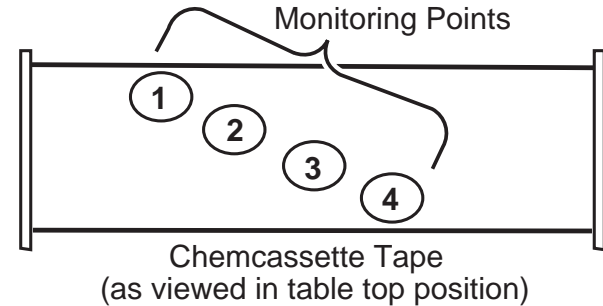

Figure 1-3: CM4 Point Stain Pattern

1.3.3 Chemcassette® Detection System

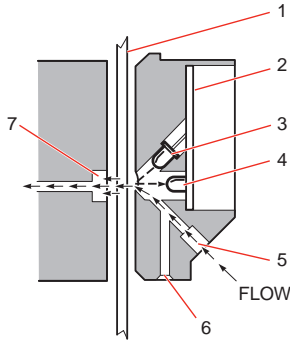

Figure 1-4: Chemcassette Detection System

Legend

1	Chemcassette® tape	5	Sample inlet
2	Electronics	6	Pressure transducer port
3	LED light source	7	Sample outlet
4	Detector		

1. The sample enters the inlet (5) and passes through the Chemcassette® tape (1) to the sample outlet (7).
2. Target gas in the sample flow reacts with the Chemcassette® tape (1) and produces a stain density proportional to the gas concentration.
3. An LED (3) in the CM4 detector head illuminates the sample stain. The detector (4) optically measures the stain.
4. The CM4 CPU interprets the stain, then reports a precise concentration level in parts-per-million (ppm) or parts-per-billion (ppb).

1.3.4 Measuring Gases

Chemcassettes® are available for measurement of gases as well as families of gases. Gases and families the CM4 detects include (See [Appendix C](#) for more information):

Ammonia (NH ₃)	Hydrogen Iodide (HI)
Arsine (AsH ₃)	Hydrogen Selenide (H ₂ Se)
Boron Trifluoride (BF ₃)	Hydrogen Sulfide (H ₂ S)
Chlorine (Cl ₂)	Hydrazine (N ₂ H ₄)
Chlorine Dioxide (ClO ₂)	Monomethyl Hydrazine (MMH)
Diborane (B ₂ H ₆)	Nitrogen Dioxide (NO ₂)
Dimethyl Amine (DMA)	Phosgene (COCl ₂)
Dimethyl Hydrazine (UDMH)	Phosphine (PH ₃)
Fluorine (F ₂)	Silane (SiH ₄)
Germane (GeH ₄)	Tert-Butyl Arsine (TBA)
Hydrogen Bromide (HBr)	Tert-Butyl Phosphine (TBP)
Hydrogen Chloride (HCl)	Triethyl Amine (TEA)
Hydrogen Cyanide (HCN)	Tetrakis(dimethylamino) titanium (TDMAT)
Hydrogen Fluoride (HF)	

The pyrolyzer Model CM4-P is specially designed to detect special gases using high temperature to “crack” those gases into Chemcassette® detectable gases. Current CM4-P detectable gases are:

Nitrogen Trifluoride (NF₃)
Methyl Fluoride (CH₃F)

The Model CM4-P is not designed to accept other calibrations, and cannot be converted.

Detection is accomplished by routing the sample from each of its four points through a high-temperature device (pyrolyzer). For example, at high temperature, NF_3 is converted to Hydrogen Fluoride (HF) which can be detected with a standard Mineral Acids Chemcassette[®] tape. The correlation algorithm between HF and NF_3 is programmed into the CM4-P, so the instrument's display and printouts read directly in ppm of NF_3 .

1.4 Displays and Controls

See [Figure 1-2](#)

The displays and controls clustered on the front panel of the CM4 include:

Display	Power LED
Status and Alarm LEDs	Flow Control
Keypad	

1.4.1 Display

The CM4 uses a 1-line, 20-character display. The CM4 display includes information about concentration and instrument faults and provides menus for CM4 programming. For more information on the display panel, see [Section 2](#).

1.4.2 Status and Alarm LEDs

Status LEDs light green when the CM4 is monitoring the point. There is one LED for each point.

- Light green - normal operation
- Flash green - point lock-on or display lock-on at that point
- Light yellow - instrument fault on that point
- Turn black - not monitoring that point

NOTE:

Status LEDs also turn yellow or flash to indicate an instrument fault.

Alarm LEDs signal gas level alarms for each point. Alarm LEDs:

- Light for Level 1 alarm concentration
- Flash for Level 2 alarm concentration

1.4.3 Keypad

Use the keypad to:

- Program the CM4
- Select specific points to monitor
- Print and display programming parameters

1.4.4 Power LED

The power LED at the bottom right of the panel indicates the CM4 is powered up. A blinking yellow power LED indicates the keypad is locked, requiring a passcode for any CM4 operation.

1.4.5 Flow Control

Four metering valves, one for each point, control the sample flow through the Chemcassette[®] detection system.

1.5 Electrical Connections

All electrical connections are made at the rear of the CM4. User installed wiring connects to a removable relay panel at the top of the instrument, allowing the chassis to be removed without disturbing connections.

1.5.1 I/O Panel

The I/O (Input/Output) panel contains connections to 14 form C relays to activate external devices:

- A watch dog relay (RY12) which indicates power loss or a CPU failure
- Eight gas alarm relays which indicate Level 1 and Level 2 alarms

- Two general gas alarm relays which indicate Level 1 and Level 2 alarms at any point
- A Maintenance fault relay (RY8) which indicates the CM4 needs attention but is continuing to monitor
- An Instrument fault relay (RY10) which indicates the CM4 is unable to monitor one or more points

In addition, the I/O panel includes:

- Terminals for the current loop options, which produce a 4-20 mA output signal in direct variation to the gas concentration at each point
- Terminals for the remote reset option, which permit resetting of faults and alarms for specific points

1.5.2 Power Connection

Connect AC power to the CM4 at the rear panel. The power switch is located above the power line connection.

1.5.3 Optional Serial Output

Install the optional DB9 (nine-pin) serial data and printer connectors on the back panel.

1.6 Alarms

The CM4 has alarms that:

- Warn of Level 1 or Level 2 low or high concentrations of the monitored gas
- Trigger relays to external devices

[Section 3.10](#) describes wiring.

[Section 4](#) describes operation modes and basic operating procedures.

1.6.1 General and Point Gas Alarms

The factory default setting for the Level 1 alarm is the threshold limit value (TLV) of the monitored gas. The default setting for the Level 2 alarm is two times the TLV. Level 1 and 2 alarms can be factory set to 1/2 TLV and 1 TLV by specifying part number 1874-0330.

You can also set individual alarm levels for each sample point. Separate alarm levels for each point provide added protection in critical locations and allow you to customize the settings to meet the specific needs of your site.

1.6.2 Activating an Alarm

When the CM4 detects a gas concentration that exceeds a programmed alarm level, it activates a series of signals. The CM4 continues monitoring during an alarm condition.

NOTE:

When a Level 2 alarm activates, the Level 1 alarm always activates.

- Alarm LEDs indicate Level 1 and Level 2 alarms for the appropriate point
- The gas alarm relay contacts activate for the appropriate point
- The general alarm contacts activate
- The display continues to show the point number, gas type and gas concentrations
- The instrument generates the appropriate current loop signal (2-20 mA/4-20 mA) and an audible tone
- Alarm information is sent to the printer for printing (if enabled)
- Alarm data (most recent 16 alarm events) is stored in memory
- Alarm information is made available over the optional digital network port

1.7 Instrument Diagnostics

The CM4 provides diagnostic instrument fault and maintenance requirement indications. These activate one of the following:

- One or both fault relays activate
- On-board memory stores most recent eight fault events for later recall
- Fault information is sent to the printer (if enabled)
- Status LEDs light yellow for the appropriate point to indicate instrument faults
- The display shows the fault information
- If the fault generated is an instrument fault and the CM4 is appropriately configured, the current level on the optional analog 4-20 mA output port is reduced to 2 mA.

Condition	Point Status LED	Point Alarm LED	Relays Activated	Beeping Audio Alarm	Display
Monitoring	Green	OFF	All OFF	OFF	Current concentrations (each point displayed for four seconds)
Level 1 alarm	Green	Red (steady)	- Low level alarm for affected point - General low level alarm	ON	Current concentrations
Level 2 alarm	Green	Flashing red	- High and low level alarms for affected point - General high and low level alarms	ON	Current concentrations
Low Chemcassette maintenance fault (monitoring continues) (See Appendix B)	Green	OFF	Maintenance fault	OFF	Current concentrations followed by fault message (as last message in sequence)
Power interruption or CPU fault	OFF or random	OFF or random	Watchdog fault	OFF	Blank or random
Instrument Fault (monitoring continues on unaffected points)	Yellow	OFF	Instrument fault	OFF	Current concentrations followed by fault message (as last message in sequence)
Instrument fault (monitoring suspended)	Yellow	OFF	Instrument fault	OFF	Fault Message

Table 1-1: Instrument Alarms

2 Controls and Indicators

2.1 Introduction

This section identifies:

- The control panel display, keypad, and LEDs ([Section 2.2](#))
- Relays ([Section 2.3](#))
- Sample flow controls ([Section 2.4](#))

NOTE:

On newer style CM4 (S/N XXX-5000 and greater) and all CM4-P models, the flow controls (item 6) are located on the lower left of the front panel. An air filter (item 10) is located on the lower right.

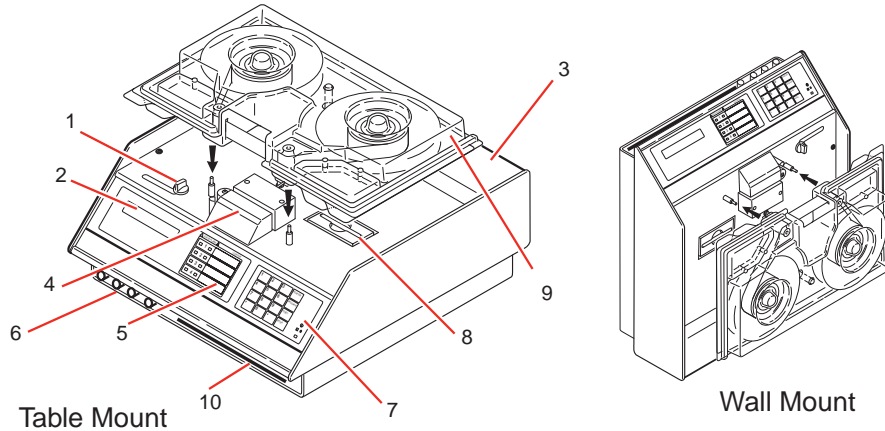

Figure 2-1: CM4 Components and Controls

Legend

1	Tape load lever	6	Flow controls
2	20-character display	7	Keypad
3	Alarm relays	8	Filter block
4	Detectors and electronics	9	Carrier
5	Status and alarm LEDs	10	Air filter

2.2 Control Panel

The front control panel consists of:

- Display (1)
- Status and alarm LEDs and point ID Labels (2)
- Keypad (3)
- Power LED indicator (4)

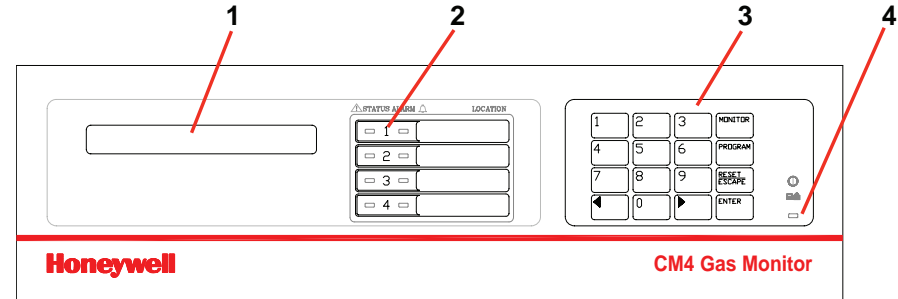

Figure 2-2: Control Panel

Legend

1	Display	3	Keypad
2	Status LED and point ID labels	4	Power/Lock LED

2.2.1 Display

The display is a 1-line by 20-character vacuum fluorescent display that shows program and operation information.

In the Monitor Mode, if no gas concentration is detected and in the Idle Mode, the display brightness is reduced to 60% of full brightness. This feature extends the life of the vacuum fluorescent display.

2.2.2 LEDs and Point ID Labels

Each of the four detection points includes two LEDs:

- Point status LED
- Point alarm LED

Point Status LED

The monitoring status LEDs indicate the following conditions:

- Green for the specific point when the CM4 is monitoring that point
- Yellow, steady or flashing indicating fault
- Red, steady or flashing indicating alarm
- Off when the CM4 is not monitoring that point

Alarm LED

To indicate gas alarm condition, the LEDs:

- Light steady red when Level 1 alarm (low level gas alarm) occurs for any monitored point
- Flash red when Level 2 alarm (high level gas alarm) occurs for any monitored point

Point ID Labels

Identify each point using the write-on surface provided. Use a fiber-tipped permanent marker. You can remove any marks with acetone without damaging the panel.

2.2.3 Keypad

The keypad consists of:

- Numeric keys
- Function keys
- Cursor Arrow Left/Right keys

Numeric Keys

Use the numeric keys, 1 through 9 and 0, to:

- Enter programming values
- Display and select specific detection points

Function Keys

Function keys access menus and functions. Function keys include:

- MONITOR
- PROGRAM
- RESET
- ENTER

Functions are described in detail later in this manual, Sections 4 through 8.

Cursor Arrow Right/Left Keys

Cursor Arrow Left/Right keys scroll the display backwards and forwards to program and view information. Pressing the cursor arrow keys twice while monitoring also advances the tape.

2.2.4 Power Indicator LED

The power indicator LED is:

- On steady green during operation
- Flashes yellow to indicate the keypad is locked

See [Section 7.1.1](#) to activate the keypad using the passcode. See [Section 7.7](#) for passcode information.

2.3 Relays

Relays activate to indicate significant change in gas concentration or instrument status. The relays are on a removable panel on the back of the instrument. The main chassis of the unit is easily removed while leaving terminal contacts intact. A single ribbon cable provides the wiring connection.

Relays provide both normally open and normally closed contacts. There are separate relays for:

- Level 1 alarm (low level) for each point (four relays: RY1, RY3, RY5 and RY7)
- Level 2 alarm (high level) for each point (four relays: RY9, R11, RY13 and RY14)
- General Level 1 alarm for any monitoring point (RY2)
- General Level 2 alarm for any monitoring point (RY4)
- Instrument fault (RY10)
- Maintenance fault (RY8)
- Watch dog (power loss or CPU failure notification) (RY12)
- One “out of monitoring” (RY6)

See [Section 3.11](#) for information on wiring relays.

2.4 Sample Flow Controls

Flow controls adjust the sample flow through the Chemcassette®. For details of sample flow adjustments, see [Section 8.7](#).

3 Installation

3.1 Introduction

The installation and initial start-up procedure for the CM4 consists of six steps, described in this and the following sections:

1. Physical installation of the instrument at the site ([Section 3: Installation](#)).
2. Initial power-up ([Section 4: Basic Operation](#)).
3. Instrument programming configurations ([Section 7: Set-Up Menu](#)).
4. Verification of the integrity of the alarm system ([Section 8.3: Function 4.2–Alarm Test](#)).
5. Adjustment of CM4 sample flow rates ([Section 8.7: Function 4.6–Set Flow](#)).
6. Verification of the optics system ([Section 5.2: Function 1.1–Optics Verify](#)).

3.1.1 Mounting Alternatives

The CM4 is designed to be operated in four different configurations:

- Tabletop
- Wall mount
- Rack kit (customer-supplied rack)
- Rack enclosure (MDA-supplied cabinet)

The tabletop is the basic, stand-alone configuration that is used throughout this manual to show instrument operation. As needed, certain illustrations will also show the wall mount configuration for added clarity.

Wall and rack configurations require either adapter kits or a separate enclosure. See [Section 3.5.3](#) for information.

When selecting a site for installation of the CM4, consider the mounting option best suited for your location. Operators can place the CM4 up to

300 feet (90 m) from monitoring points to monitor gas concentrations in an area removed from the location where gas may actually be leaking.

3.1.2 Accessory Kit

Your CM4 includes an Accessory Kit (P/N 874265) which contains this manual (on CD), a calibration card and other items used in installation.

3.1.3 Installation Steps

Proceed through each of the steps to install the CM4. This section details physical installation procedures which you should perform in order:

- Surveying the Installation Site ([Section 3.3](#))
- Placement of the CM4 ([Section 3.3.1](#))
- Sample Locations ([Section 3.4](#))
- Configuring for Mounting Method ([Section 3.5](#) and [Section 10](#) for options)
- Installing Sample Lines ([Section 3.6](#))
- Installing Sample Line Particulate Filters ([Section 3.7](#))
- Installing Pump Exhaust Line ([Section 3.8](#))
- Connecting AC Power Cord ([Section 3.9](#))
- Wiring Relays ([Section 3.10](#))
- Wiring Optional Current Loop (4-20 mA Output) ([Section 3.11](#))
- Loading Chemcassette[®] Tape ([Section 3.12](#))

3.2 Components and Connections for Installation

All of the sample line fittings and most electrical terminals for installing the CM4 are at the back of the instrument.

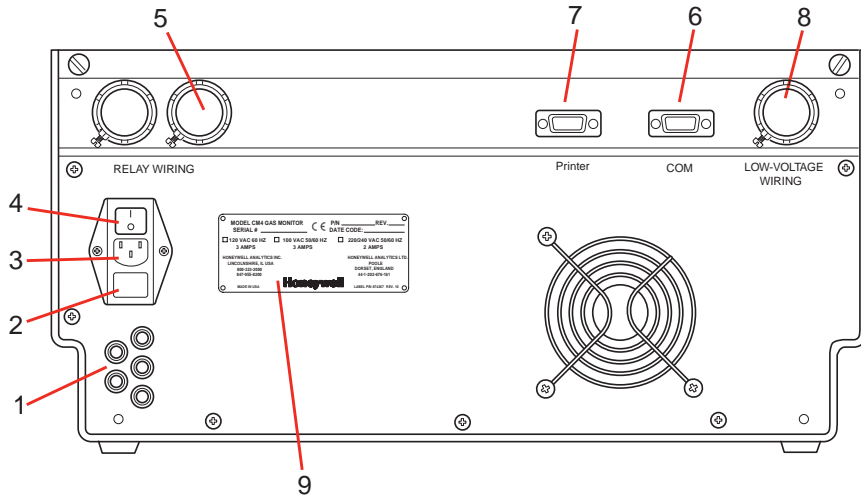

Figure 3-1: CM4 Back Panel

Legend

1	Sample inlets and exhaust	6	COM port
2	Fuse	7	Printer port
3	Line power in	8	Current loop knockout
4	Power switch	9	Serial number label
5	Alarm wire panel knockouts		

3.3 Surveying the Installation Site

A survey of the site helps you make important decisions before installing your CM4. Topics in this section assist you with appropriate placement of the CM4 and in determining if you have special filtering needs at the sampling location. The site should:

- Be remote from the monitored location, not sharing the atmosphere
- Have sufficient ventilation for cabinet cooling
- Have power available
- Be indoors in an area that is not subject to wide variations in temperature (not greater than gradients of 25°C per hour) and humidity

NOTE:

The specified humidity is 20-80% RH and a temperature between 10°C to 40°C.

3.3.1 Placement of the CM4

Install the CM4 in an environmentally-protected setting remote from the manufacturing or storage locations that it monitors.

Operators can place the CM4 up to 300 feet (90 m) from monitoring points to monitor gas concentrations in an area removed from the location where gas may actually be leaking.

3.3.2 Exposure to Dust and Humidity

Exposure to corrosive gases or materials, excess moisture, dust and other unusual environmental conditions could seriously hamper the instrument's monitoring ability and could damage the instrument.

Always allow room behind the CM4 for ventilation and servicing. See the installation drawing #874000-I (included with the CM4) for requirements.

3.3.3 Sample Transport Time

Although transport times are very short (<40 seconds), you should install the monitor in a location central to all four points to achieve equal sample transport times during monitoring. The shorter the sample line, the shorter the response time. If monitoring a critical point, it may be desirable to place the instrument near that critical point to reduce sample transport time for that location. See [Appendix A](#) for transport times.

3.3.4 Instrument Dimensions

Instrument dimensions are important factors in instrument placement. For the basic tabletop configuration, the dimensions are approximately 9.187 inches (23.3 cm) high. See [Section 3.5](#) for required clearances and mounting dimension for the optional wall and rack mount configurations. The CM4 is 17 inches (43 cm) wide and 17-3/4 inches (45 cm) in depth. The CM4 weighs about 50 pounds (23 kg).

3.4 Sample Locations

Before installing the CM4, evaluate the sampling locations to determine if excessive dust or moisture are present. Use an external filter at the end of all sample lines. See [Appendix A](#) for selection of appropriate filter type for the target gas. Dust may be a result of construction as well as manufacturing activities. Moisture may occur from rain entering a line at an outdoor sampling location or from condensation caused by temperature fluctuations. Water condensation in the sample lines could cause false alarms.

NOTE:

Variables such as air flow, the molecular weight and temperature of the sample gas, and the physical conditions of the areas being monitored influence the placement of the sampling locations. You may need to consult your company industrial hygiene or safety officer before installing sample lines to determine your company's policy related to sampling locations and monitoring of the desired sample gas.

3.4.1 Sample Line Particulate Filter Use

Refer to [Appendix A](#) to install sample line filter and to determine if a filter can be used at the location.

3.4.2 Special Considerations for Positive Pressure

A transducer inside the CM4 can detect when positive pressure is present to effectively monitor positive pressure locations. An operational message indicates when a point has detected positive pressure.

3.5 Configuring for Mounting Method

The CM4 is factory configured for tabletop use. Rack mounting and wall mounting require additional procedures for mounting and connections of cable and tubing.

For optional configurations, Honeywell Analytics supplies the following installation drawings:

- Wall mount kit: drawing #874014-I
- Rack mount kit: drawing #874013-I (customer-supplied rack)
- Rack enclosure: drawing #874550-I (MDA-supplied cabinet)

3.5.1 Wall Mount

Figure 3-2 shows wall mounting orientation and dimensions. The mounting kit supplied by Honeywell Analytics includes all hardware and fasteners shown except for wall anchors. Here are important installation points:

- For detailed installation prints, ask for MDA drawing #874014-I
- Use appropriate anchors to secure brackets to wall
- If installing multiple CM4s, allow a minimum 8 inch vertical separation between brackets
- Make sure brackets are securely fastened and level before locking instrument in position

CAUTION

The CM4 weighs about 50 pounds (23 kg). Make sure all installation steps and handling procedures are done with protection and safety margin for this load.

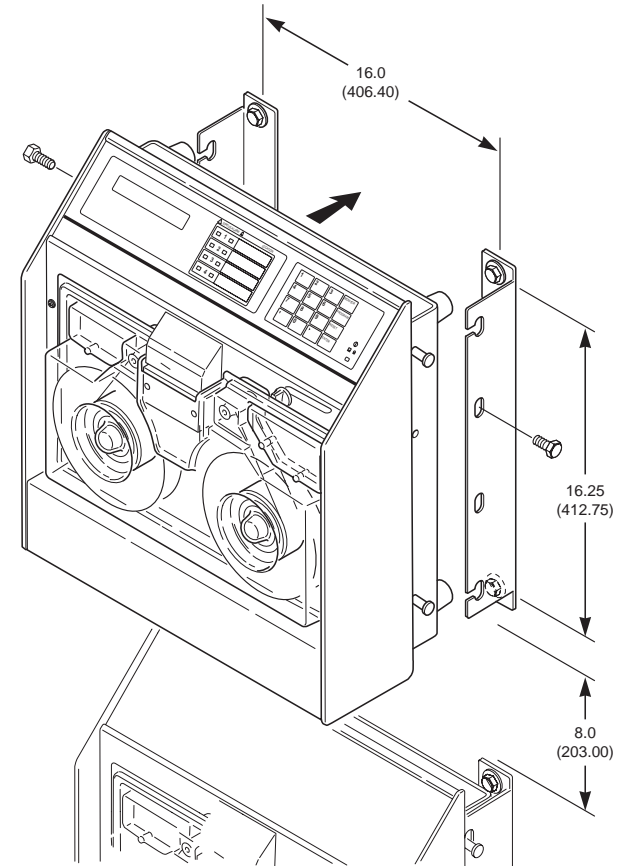

Figure 3-2: Wall Mount

3.5.2 Rack Mount Kit

The CM4 Rack Kit includes two custom slides and hardware for installation in a customer-supplied standard 19 inch rack. For detailed installation prints, ask for MDA drawing #874550-I.

Figures 3-3, 3-4, and 3-5 show rack mounting installation details.

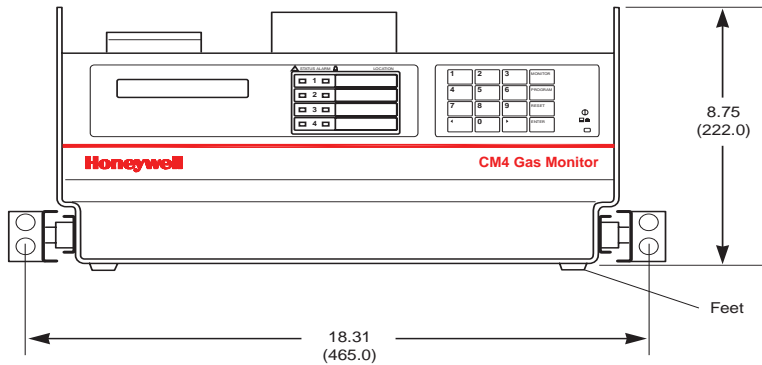

Figure 3-3: Rack Kit Dimensions

CAUTION

Verify power is Off before disconnecting customer I/O board.

Follow these points when installing the rack mount:

- Verify proper clearances and dimensions for instrument placement. See **Figure 3-3**
- Remove feet
- Allow 9.00 inch (23 cm) height between units for proper clearance
- **Figure 3-4** shows right side fastener locations. Left side installation is identical
- In the recessed position, make sure there is 3-1/4 inch (8.25 cm) clearance for the loop of slack cable as shown in **Figure 3-5**

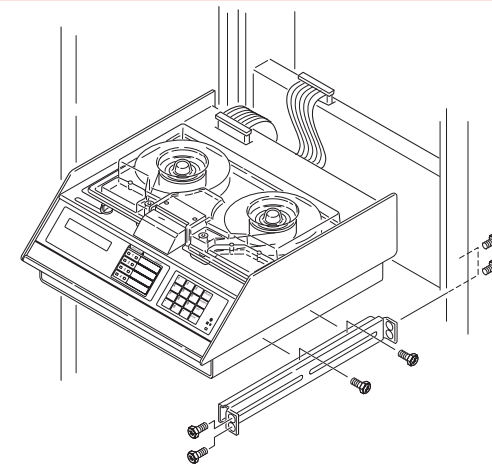
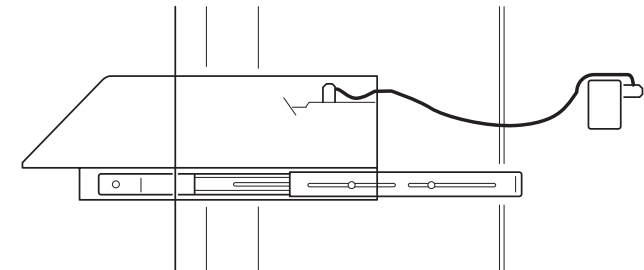

Figure 3-4: Mounting



Adjustable up to 28" between front/rear mounting rail

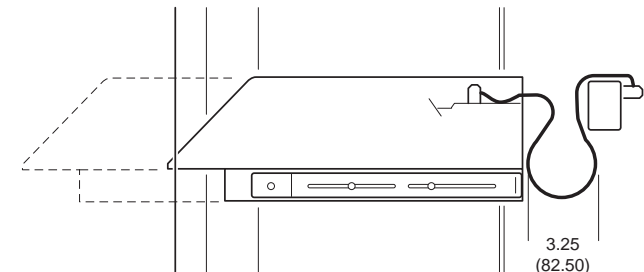

Figure 3-5: Cable Attachments

3.5.3 Rack Mounting the CM4-P

 **CAUTION**

The pyrolyzer operates at a very high temperature, therefore CM4-P units should not be placed immediately adjacent to each other. To provide effective air circulation around the Model CM4-P cabinets, the configuration guidelines in Table 3-1 must be maintained.

The recommended quantities and combinations of CM4 and CM4-P units in a rack is shown in Table 3-1.

Configuration	Qty CM4	Qty CM4-P	Qty Printer and Share Box
1	5	2	0
2	3	3	0
3	1	4	0
4	3	2	1
5	1	3	1
6	0	4	1
7	7	0	0

Table 3-1: CM4 Rack Mount Loading Capacity

The Model CM4-P is not retrofittable to “System16-style” enclosures (P/N 874293). Only “Schroff-Style” enclosures (P/N 1874-0050 and 1874-051) may be used with these units.

3.5.4 Rack Enclosures

The rack enclosure configurations provide space for up to seven CM4 units (or five CM4 units plus a printer) in an Honeywell Analytics-supplied cabinet.

The CM4 rack enclosure will be custom configured for each application. Supplemental installation and start-up instructions will be provided with the cabinet. As a pre-installation step, users must prepare floor anchors to secure the base of the cabinet and prevent tipping. See [Figure 3-6](#). For detailed installation prints, see [Appendix F - Installation Drawings](#).

NOTE

There are several kits available to mount CM4 and CM4-P units into existing rack enclosures. Contact Honeywell Analytics for more information.

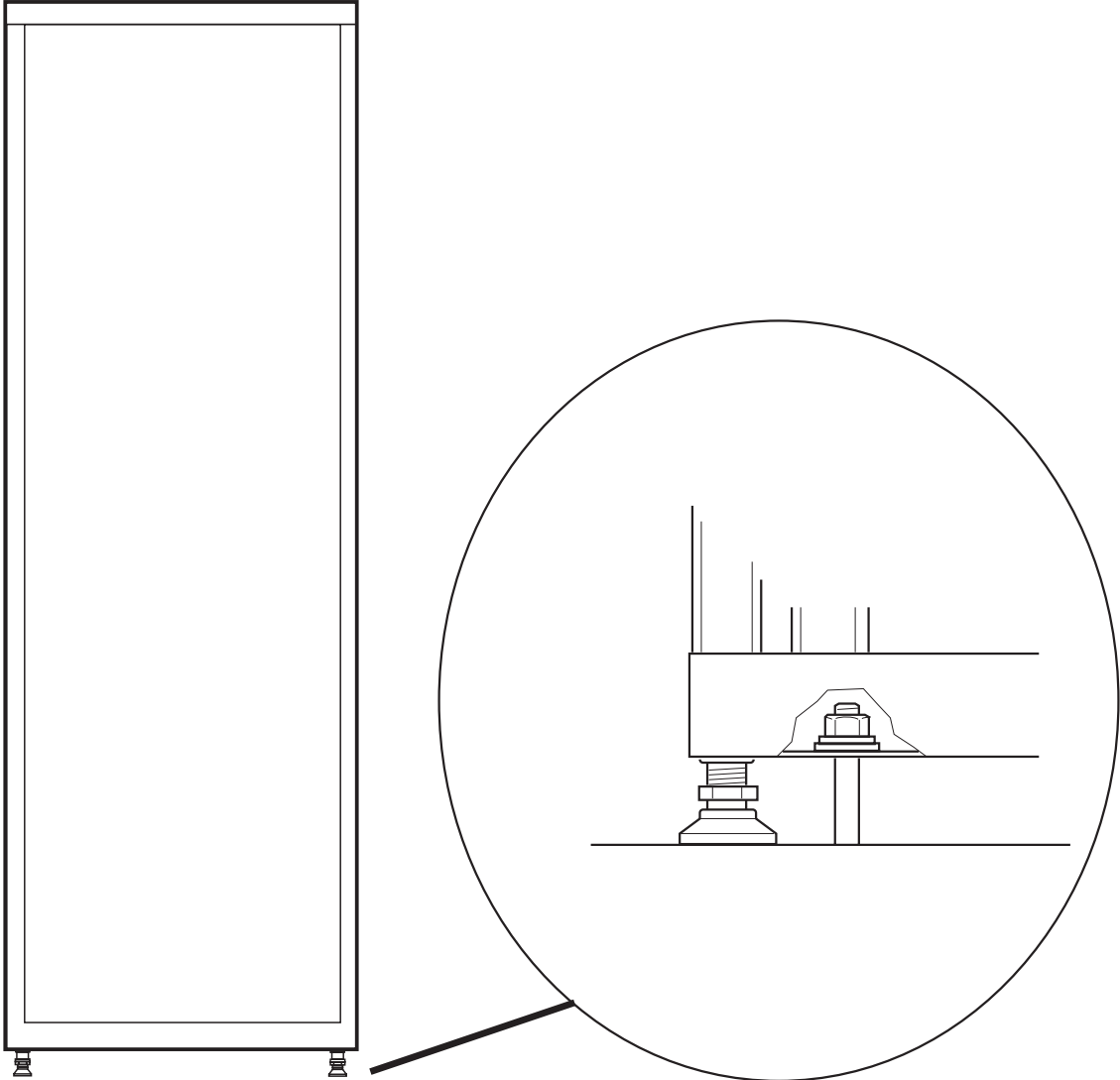

Figure 3-6: Rack Enclosure

3.6 Installing Sample Lines

FEP Teflon tubing must be used to assure proper sample transport. Other types of tubing are not sufficiently inert. Your Model CM4 includes a 400 foot (120 m) roll of 1/4-inch (6.35 mm) x 3/16-inch (4.7 mm) I.D. FEP Teflon sample line tubing included in CM4 kit (P/N 874008). Additional FEP tubing can be ordered from Honeywell Analytics.

NOTE:

Honeywell Analytics supplies FEP grade Teflon® tubing with all new instruments. This tubing is manufactured to our own strict specifications, and has been purged of all by-products of the manufacturing process. On occasion, users have supplied their own tubing. Should you choose to use your own tubing, be advised that some brands of FEP tubing off-gas small amounts of HF, which can be detected on start up by MDA Scientific instruments configured for detecting mineral acids gases (HBr, HCl, HF, NF₃). Before enabling building alarm systems, make certain that 1) you have installed the correct Chemcassette®, and 2) your instrument reads zero.

Install sample lines from each location to the CM4, allowing room to access the back panel. This procedure involves:

- Sample line requirements (**Section 3.6.1**)
- Tubing connections (**Section 3.6.2**)
- Sample line inlet connections (**Section 3.6.3**)
- Point legend (**Section 3.6.4**)

3.6.1 Sample Line Requirements for Installation

Follow the general requirements listed below when installing sample lines.

- Sample lines should not exceed 300 feet (90 m) in length



CAUTION

Hydrogen Bromide (HBr) (low level) using the standard Mineral Acids Chemcassette® (p/n 874337) has a sample line limit of 100 feet.

Hydrogen Bromide (HBr) (low level) using the XP Mineral Acids Chemcassette® (p/n 1874-9310) has a sample line limit of 300 feet.

Hydrazine (N₂H₄), Monomethyl Hydrazine (MMH) and 1,1 Dimethyl Hydrazine (UDMH) have a sample line limit of 50 feet.

- All runs should be as direct as possible to improve transport time (see **Appendix A** for transport times)
- Make sure there is some slack in the tubing and the power line to allow access to the back of the cabinet
- Avoid running sample lines through areas of great temperature extremes, such as adjacent to steam or chiller lines
- Sample lines should not be crimped, bent to less than a 5 inch (12 cm) radius, or placed in an area where weight could collapse the tubing. Sample lines should be easily accessible for periodic inspection.
- Leave as many bends as possible exposed for periodic visual inspection of the line for kinked or damaged tubing

Check each sample line installation for leak integrity after completing installation of the CM4. The leak check procedure is described in **Appendix B**. Also use this procedure to detect leaking or severed tubing after events, such as construction, which may have affected the integrity of the tubing.

3.6.2 Tubing Connections

To prepare for installation of sample lines, remove the FEP Teflon tubing (3/16 inch I.D. x 1/4 inch O.D.) from the Installation Kit. The back of the unit includes five connections:

- | | |
|--------------------------|--------------------------|
| 1 Sample Inlet - Point 1 | 4 Sample Inlet - Point 4 |
| 2 Sample Inlet - Point 2 | 5 Exhaust |
| 3 Sample Inlet - Point 3 | |

NOTE:

Always perform a leak check after installing all sample lines. See [Appendix B](#).

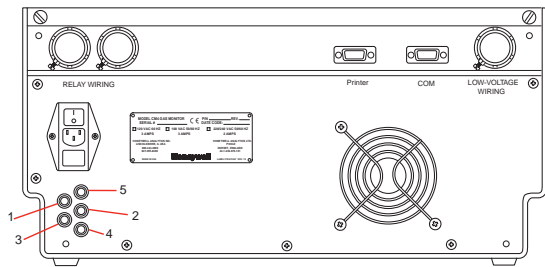

Figure 3-7: Tubing Connections

Legend

- | | |
|--------------------------|--------------------------|
| 1 Sample Inlet - Point 1 | 4 Sample Inlet - Point 4 |
| 2 Sample Inlet - Point 2 | 5 Exhaust |
| 3 Sample Inlet - Point 3 | |

3.6.3 Sample Line Inlet Connections

Each inlet has a quick connect/disconnect fitting with an internal O-ring and an external grab ring. To install a tube into a sample line inlet, insert the tube far enough into the fitting to ensure that the tube has passed through both the external grab ring and the internal O-ring and is firmly seated against the stop. The insertion

depth for a correctly installed sampling line is 1/2 inch to 5/8 inch (12-16 mm). Verify the insertion depth by holding the tube and marking with your thumb where it emerges from the fitting. Remove the tube to measure the insertion depth.



CAUTION

Improper installation of the tube into the connector results in dilution of the sample.

3.6.4 Point Legend

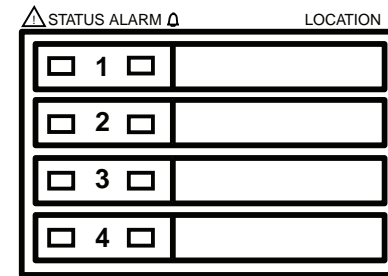

Figure 3-9: Point Legend

To keep track of the location corresponding to each point, the CM4 front panel contains an area to the right of the status and alarm LEDs for point identification. Write the name of each location on the area next to the point alarm LED on the control panel. Use a fiber-tipped permanent marker.

3.7 Installing Sample Line Particulate Filters

See [Appendix A](#) to determine if you can use sample line filters with your target gas.

Attach a sample line filter to the sampling end of the line only if you have determined that environmental dust or moisture is a concern at the sampling location.



CAUTION

When attempting to use a sample line particulate filter, keep in mind that excess amounts of dirt in the filters reduce the sample flow and may affect concentration readings of the analyzer.

See [Appendix A](#) to determine which filter to use with your target gas.

3.8 Installing Pump Exhaust Line

This section describes exhaust connections and installation.

3.8.1 Exhaust Line Installation Guidelines

Properly ventilate the exhaust line, which should not exceed 50 feet (15 m) in length. If longer distances are required, contact Honeywell Analytics.

- If multiple CM4s are installed in the same location, use a separate line for each exhaust outlet
- Do not crimp exhaust lines, or place them in an area where weight could collapse the tubing, or bend them to less than a 5-inch (12 cm) radius
- Leave as many bends as possible exposed for periodic visual inspection of the line for kinked or damaged tubing
- Varying exhaust pressure can induce pump failure

3.8.2 Exhaust Tubing Specifications

The instrument includes 50 feet (15 m) of 3/16 inch (4.7 mm) I.D. x 1/4 inch (6.35 mm) O.D. polypropylene tubing.

3.9 Connecting AC Power Cord

The CM4 requires a dedicated AC power line. Configurations include:

- 120 volt \pm 10%; 60 Hertz; 3 amp
- 100 volt \pm 10%; 50 or 60 Hertz; 3 amp
- 220/240 volts \pm 10%; 50 or 60 Hertz; 2 amp

The CM4-P requires:

- 100-120 volt \pm 10%; 60 Hertz; 5 amp
- 220/240 volts \pm 10%; 50 or 60 Hertz; 4 amp

Plug the line into a dedicated outlet having sufficient amperage capacity.

Line voltage should fluctuate no more than \pm 10%.

3.10 Wiring Relays

This section describes relay:

- Contacts
- Ratings
- Wiring guidelines

WARNING

Use caution when servicing fuses or terminal blocks. Power to contacts is supplied externally.

3.10.1 Relay Contacts

The CM4 has 13 form C, single-pole, double-throw relays that activate external alarm devices. Contacts are available for each circuit to accommodate installation of external devices.

The relay panel may be removed from the CM4 chassis without disconnecting relay wiring. This allows you to replace the CM4 without having to reinstall the relay connections.

Each relay has three terminal contacts.

- Normally open
- Fused common
- Normally closed

The terminal blocks for the relay contacts are located on the relay panel. See [Figure 3-11](#). Relays include:

- Four Level 1 alarms (RY1, RY3, RY5, RY7)
- Four Level 2 alarms (RY9, RY11, RY13, RY14)
- One general Level 1 alarm (RY2)
- One general Level 2 alarm (RY4)
- One watch dog (power loss/CPU failure) relay (RY12)
- One maintenance fault relay (RY8)
- One instrument fault relay (RY10)
- One “Out of Monitoring” relay (RY6)

NOTE:

Make sure that watch dog relays and instrument fault relays are wired in series to ensure that any fault will trigger a diagnostic alarm. This will ensure a fail-safe operation.

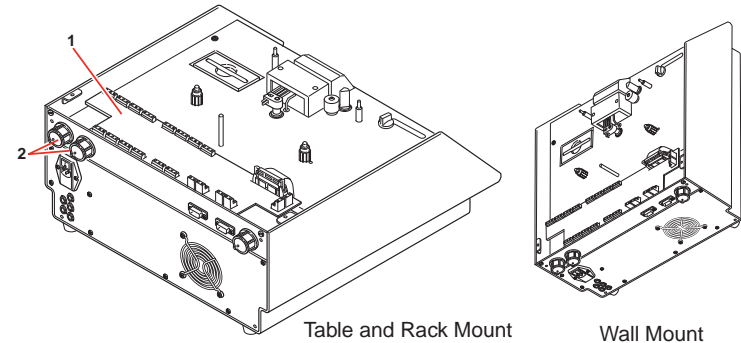

Figure 3-10: Relay Panel (Cover Removed)

Legend

1	I/O panel (cover removed)	2	Route relay wiring through knockouts as required
---	---------------------------	---	--------------------------------------------------

3.10.2 Ratings

To ensure reliable contact operation, the following limits must be observed:

- 0.1 to 2.0 amps
- @5-24 VDC or
- @5-120 VDC

CAUTION

The alarm relay has a minimum load requirement of greater than 5V and 100 mA. For reliable relay operation, ensure the alarm circuit meets these requirements.

The relay contacts are protected by metal oxide varistors rated for 120 VAC maximum operation.

3.10.3 Wiring Guidelines

To wire the alarm relays:

- Use shielded cable or conduit. See [Appendix E](#) for additional cable information.

CAUTION

Failure to replace and retighten hardware after servicing can adversely affect instrument performance and EMC compliance. Make certain all fasteners are reinstalled and firmly tightened. This will ensure a proper ground.

- Connect grounds to stud at lower left corner of the I/O panel. See [Figure 3-11](#)
- Use #8 hardware provided
- Use a single, solid or stranded wire (not exceeding 14 gauge) per terminal block connection
- Do not switch DC current with the relay contact unless you are using counter electromotive force (CEMF) protection such as a suppression diode
- Do not use the CM4 power supply for external alarm power

IMPORTANT:

Make sure all connections comply with applicable RFI/EMI standards.

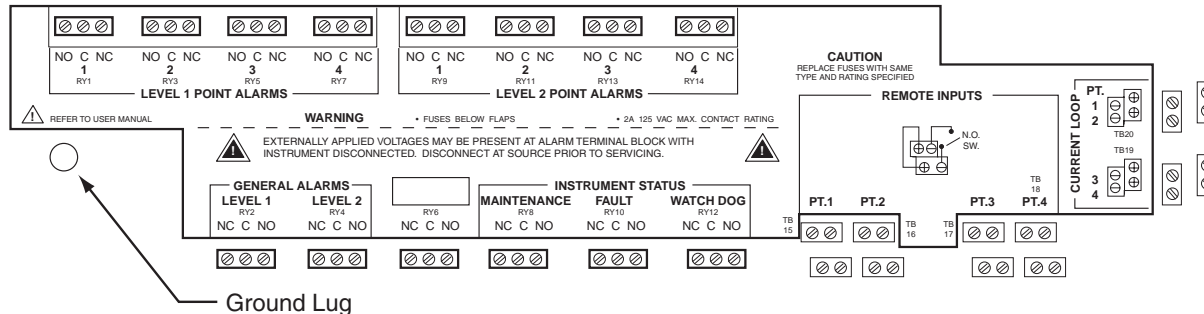

Figure 3-11: I/O Panel Connections

3.11 Wiring Optional Current Loop (4-20 mA Output)

Each current loop output produces a current which varies linearly from 4 to 20 mA as the concentration of gas varies from zero to a user-programmable full scale concentration. The gas concentration for 20 mA full scale defaults to the full scale of the gas, but can be configured lower.

Furthermore, the CM4 can be configured lower to reduce these output currents to 2 mA if certain faults occur. These outputs will drop to zero mA after a power failure.

The current loop connection points are located on the I/O Panel.

The impedance range of the analog output is 100-800 ohms.

All wiring should follow the wiring guidelines described in Wiring Guidelines ([Section 3.10.3](#)).

3.12 Loading Chemcassette® Tape

For Chemcassette® loading procedure, see [Section 9.2.3](#) and [9.2.4](#).

WARNING

Be sure to install the correct Chemcassette®. (See [Appendix A](#) for part number information.) Make sure the label on the Chemcassette® and the label on the analyzer correspond. Incorrect Chemcassette® replacement defeats the CM4's ability to warn of dangerous gas concentrations.

NOTE:

Only one Chemcassette® type should be used with each carrier.

3.13 Power On/Off

Use the rocker switch on the right rear of the unit, above the power cord, to turn on power to the Model CM4. For Rack Mount units, use the power panel at the top of the rack. The number of each switch correlates to the position of the CM4 unit in the rack.

The display shows:

CM4

Upon power-up, the CM4 conducts a self-diagnostic procedure to check:

- Memory
- Hardware
- Voltages

The display shows:

SELF TEST
CM4 V3.05

After this display, the Chemcassette® advances and the pump turns on. The display shows:

STABILIZING
then
CURRENTLY MONITORING

NOTE:

The CM4 automatically attempts to enter the Monitoring Mode whenever it is switched on.

3.14 Installation Notice

Press PROGRAM to exit the Monitor Mode.

You must perform the following Quick-start procedure at installation before operating the instrument. With the Chemcassette® and tubing installed:

1. Access Service Mode 4.8 in the SERVICE (4.SERVICE) menu. The display will show:

PRESSURE CTS = 832
1 = PUMP 2 = LIMITS

2. Press 1 to switch the pump on. A new pressure counts value will appear in the display. This is your “normal reading.”
3. Select 2 to set the High and Low Limits.
4. Set the High Limit value to the “normal reading” plus 52 ± 12 .
5. Set the Low Limit value to the “normal reading” minus 52 ± 12 .
6. When the values are set, press ENTER to store the values.

Refer to [Section 8.9](#) for more details on this procedure.

3.15 Function and Cursor Keys

This section describes function keys and cursor keys.

3.15.1 MONITOR

Press MONITOR to initiate monitoring.

3.15.2 PROGRAM

Press PROGRAM to exit the Monitor Mode.

3.15.3 RESET/ESCAPE

Press RESET to reset all CM4 alarm and fault LEDs and relays. Also, press RESET to escape from subroutines.

3.15.4 ENTER

Press ENTER to confirm configuration changes.

3.15.5 CURSOR ARROW LEFT/RIGHT

Press CURSOR ARROW LEFT/RIGHT to:

- Scroll the display forward/backward to access menus and functions
- View and configure CM4 operating parameters, including calibrating, reviewing alarm history, reviewing configuration, setting-up for operation, and servicing the instrument.

4 Basic Operation

4.1 Introduction

This section describes:

- Monitor Mode ([Section 4.2](#))
- Program Mode ([Section 4.3](#))
- Alarms and Faults ([Section 4.4](#))
- Accessing Programming Functions ([Section 4.5](#))
- CM4 Menu Structure ([Section 4.6](#))
- Keypad Locking Feature ([Section 4.7](#))

If you are not working with a CM4 as you read these sections, refer to the illustrations in [Section 2](#).

4.2 Monitor Mode

Monitor Mode is the CM4's standard operation state. After the instrument is powered, the pump turns on and the instrument takes initial zero readings and turns on the sample flow valve. The instrument:

- Continuously monitors gas concentrations at all four points connected to the CM4
- Measures and calculates gas concentrations every second for each of the four points

Response time is determined by the gas type and the alarm level setting. The display shows the first reading:

```
PT 1  0 PPB  AsH3
```

The display continues to show the concentration monitored at each point for a user-specified number of seconds, with a four-second default:

```
PT 2  0 PPB  AsH3
```

```
PT 3  0 PPB  AsH3
```

```
PT 2  0 PPB  AsH3
```

A fifth status line will be displayed, if applicable.

The concentration information for each point may be sent to three optional outputs:

- Isolated current loop (4-20 mA)
- Serial
- Printer

NOTE:

Any time power is lost to the CM4, it enters Monitor Mode automatically after power is restored.

When switching On Model CM4-P, the instrument requires up to ten minutes for the pyrolyzer to heat up to its operating temperature. The following display appears momentarily:

```
MONITOR MODE
```

The display then reads:

```
WARMING UP 600 SEC
```

Warm-up time is typically faster than initially indicated on the display above. The Model CM4-P will usually begin monitoring approximately one minute after <MONITOR> is pressed.

During the warm-up cycle, the display status LEDs will be flashing green. The Chemcassette advances as the instrument enters analysis. The display reads:

```
CURRENTLY MONITORING
```

During monitoring, the status LEDs for each active point will be solid green. When the first concentration has been calculated, the display will read:

```
PT1 NF3 = 0 PPM
```

CAUTION

The pyrolyzer operates at a very high temperature. Before performing any service on the instrument, always wait 30 minutes after switching off power to allow the pyrolyzer to cool.

4.2.1 Exiting Monitor Mode

To exit Monitor Mode:

1. Press PROGRAM from Monitor Mode. The CM4 displays:

```
END MONITOR? 1=Y 0=N
```

2. Press 1 within two seconds to end monitoring. If the printer option is available, the display reads:

```
PRINT TWA 1=Y 0=N
```

3. Press 1 to print TWA information. Entering 0 exits without printing TWA information.

After selecting 1, the display advances to:

```
SELECT PROGRAM ◀▶
```

4.2.2 Printing Time Weighted Averages (TWA) During Monitor Mode

If the printer option is installed, press MONITOR twice to print TWAs while in Monitor Mode. The CM4 prints the current TWA information. If there is no printer option installed, TWAs can be displayed. Refer to [Section 6.4.2](#).

4.2.3 Point Lock-On During Monitor Mode

The Point Lock-On feature causes the CM4 to optimize tape advance timing of the most rapid updating of concentration on one point.

Monitoring ceases on the other points, and the display locks-on to the one selected point. To enable a specific point:

1. Press MONITOR.
2. Press 1, 2, 3, or 4 to select the specific point.

The CM4 disables the remaining points. The Status LED for the selected point flashes green. All other point status LEDs are off.

To re-enable disabled points, either:

1. Exit Monitor Mode and then reenter.
- or
2. Press MONITOR, then 0.

If a point inadvertently remains locked on, a fault triggers after the user defined idle time (see [Section 7.6.5](#)) has elapsed. The following fault displays at the end of each point display cycle:

```
F28 PT LOCK-ON TIMEOUT
```

Press RESET to clear the fault.

4.2.4 Display Lock-On During Monitor Mode

Normally the CM4 displays the gas concentration on all enabled points. However, the CM4 can also be configured to display only one point while continuing to monitor all points.

Press 1, 2, 3, or 4 during Monitor Mode to select the specific point. The CM4 displays only the concentration for the selected point.

The display will not return to normal unless you press 0 or exit and reenter Monitor Mode.

4.2.5 Alarm History During Monitor

Use the alarm history function to print and display up to a maximum of 16 gas alarms with the most recent alarm shown first.

Print Alarm History

If the CM4 is equipped with a printer, see **Figure 4-1** for an example of a typical printout. The printout of the alarm history shows the most recent alarm first for up to 16 total alarms.

To print and display the alarm history, press ENTER followed by the point desired (1, 2, 3 or 4).

The alarm history is printed (if installed) and displayed showing the most recent alarm first. The display will scroll through each alarm. Use the cursor keys to advance through each alarm.

The CM4 sends the alarm history of the selected point to the printer. The printout shows:

- Instrument serial number
- Current date and time
- Customer name and location
- Point number
- Alarm date and time
- Concentration in ppb or ppm
- Alarm level (1 or 2)

02/29/00 14:23 CM4-851-0006 ALM HISTORY			
ALL POINTS			
ABC MANUFACTURING CO., KANSAS CITY, MO			
PT1- CM4-851-0006			
02/29/00	14:18	Level 2 Alarm	50.1 PPM NH ₃ -II
02/29/00	14:18	Level 1 Alarm	37.0 PPM NH ₃ -II
PT2-CM4-851-0006			
02/29/00	14:16	Level 1 Alarm	29.8 PPM NH ₃ -II
PT3-CM4-851-0006			
02/29/00	14:19	Level 1 Alarm	28.7 PPM NH ₃ -II
PT4-CM4-851-0006			
NO ALARM HISTORY			
END OF ALARM HISTORY			

Figure 4-1: Typical Alarm History Printout

The display returns to normal ten seconds after the last keypad entry.

Pressing RESET does not clear alarm history.

4.2.6 Fault History During Monitor Mode

Use the fault history function to print and display the four most recent faults and alarms. See **Figure 4-2**.

To print and display the fault history, press ENTER followed by 0.

The fault history is printed (if printer is installed) and displayed showing the most recent fault first. The display will scroll through each fault. Use the cursor keys to advance through each fault.

The printout of the fault history shows the most recent fault first for up to eight total faults. The printout includes:

- Instrument serial number
- Current date and time
- Customer name and location
- Fault number (Fxx)
- Fault type
- Fault date and time

The CM4 sends the fault history to the printer.

02/29/05 14:23 CM4-851-0006 FAULT HISTORY			
ABC MANUFACTURING CO., Kansas City, MO			
02/29/05	14:22	F37	TRANSPORT ERROR
02/29/05	14:22	F27	FLOW FAILURE PT1
02/29/05	14:19	F39	LOSS OF FLOW PT4
END OF FAULT HISTORY			

Figure 4-2: Typical Fault History Printout

The display returns to normal 20 seconds after the last keypad entry.

Pressing RESET does not clear fault history.

4.2.7 Display Point Flows During Monitor Mode

Use the display point flows to check sample flows without leaving monitor mode. To set or check the sample flows, press ENTER followed by 5. The four flows will be displayed in real time along with the up or down arrows if they are out of tolerance:

173	189	165 ↑	182
-----	-----	-------	-----

The display will update once per second. The display will revert to normal operation after 20 seconds or after RESET is pressed.

4.2.8 Advance Chemcassette Tape During Monitor Mode

Press the CURSOR RIGHT ARROW twice to advance the tape and view the stain pattern while remaining in Monitor Mode. Display lock-on and point lock-on remain active during this procedure. TWA information is uninterrupted.

4.3 Program Mode

To access Program Mode:

1. Press PROGRAM from Monitor Mode. The CM4 displays the message:

END MONITOR? 1=Y 0=N

2. Press 1 to end Monitor Mode and go to Program Mode.

If you do not press 1 within three seconds, the CM4 returns to Monitor Mode.

The CM4 goes to Program Mode and displays:

SELECT PROGRAM

Press CURSOR ARROW LEFT/RIGHT to select items from the four program menus.

Use the CM4 function keys while in Program Mode to:

- Program the CM4 for calibration, fault history, set-up or service
- Access Monitor Mode
- Reset fault and alarm relays

Press MONITOR to return to Monitor Mode.

NOTE:

The CM4 signals a fault after a period of idle time. See [Section 7.6.5](#) for more information.

4.4 Alarms and Faults

The CM4 continuously displays the current concentrations while monitoring.

4.4.1 Alarms

If latching relay is on (default), the Alarm LEDs will indicate a gas alarm (if gas is detected).

If non-latching is selected, the LEDs will represent the current concentration (i.e., if current concentration is below Alarm 1, Alarm LED will be off).

See [Section 7.4.4](#) for more information.

NOTE:

During alarms, the display continues to show the current gas concentration.

Level 1 alarms:

- Display current gas concentration
- Constant audio alarm tone
- Continuously lit Alarm LED

Level 2 alarms:

- Display current gas concentration
- Beeping audio alarm tone
- Flashing Alarm LED

4.4.2 Faults

If an instrument fault or maintenance fault is detected, the CM4 displays the most recent fault and a fault code after the last point display. The display cycles through points being monitored, ending the cycle with the last fault that occurred during monitoring:

```
PT 4  0 PPB  AsH3
```

This is followed by the fault information:

```
F2 LOW FLOW POINT 4
```

This fault information will continue to be displayed until the fault is reset.

Certain fatal faults will cause the CM4 to suspend monitoring. See [Appendix B](#).

4.5 Accessing Programming Functions

Programming functions are accessed using two methods:

- By scrolling through the menu selections via the arrow keys (see [Section 4.5.1](#))
- By direct numeric entry, using the menu structure (see [Section 4.5.2](#)).

4.5.1 Programming by Scrolling

1. Press PROGRAM to exit Monitor Mode. The display reads:

END MONITOR? 1=Y 0=N

2. Press 1 to end the monitoring session. The display reads:

SELECT PROGRAM ◀▶

◀▶ indicates further menu choices are available.

3. Press CURSOR ARROW LEFT/RIGHT to scroll forward/backward through the four mode (menu) choices. The display shows modes preceded by a one-digit number.

1 – CALIBRATION MODE

2 – REVIEW MODE

3 – SETUP MODE

4 – SERVICE MODE

4. Press ENTER when the display shows the desired mode selection. Depending on the entry, the CM4 displays the menu (subfunction) choices.

CALIBRATION MODE ◀▶

REVIEW MENU ◀▶

SETUP MENU ◀▶

SERVICE MENU ◀▶

5. If the option includes additional functions, the display shows ◀▶. Press CURSOR ARROW LEFT/RIGHT to display menu options.
6. Press ENTER.

4.5.2 Programming Using Direct Numeric Entry

Refer to the menu structure in **Section 4.6**. To select an item using direct numeric entry:

1. Press PROGRAM to exit Monitor Mode. The display reads:

END MONITOR? 1=Y 0=N

2. Press 1 within two seconds to end monitoring. If the printer option is available, the display reads:

PRINT TWA 1=Y 0=N

3. Press 1 to print TWA information. Entering 0 exits without printing TWA information.

After selecting 1, the display advances to:

SELECT PROGRAM ◀▶

◀▶ indicates further menu choices are available.

4. Press the numeric key corresponding to the menu numbers, functions, and points (see **Section 4.6** for complete menu listing). For example, to select the alarm history for Point 3, press the following in sequence:
 - 2 (to access the Review Mode)
 - 1 (to access Alarm History)
 - 3 (to specify Point 3)

NOTE:

The following sections describe accessing menus and functions using the scrolling method and function keys. Once you become familiar with the menu structure, you will be able to access menus and functions more quickly using direct numeric entry rather than using the scrolling and function key method.

4.6 CM4 Menu Structure

This section shows the complete CM4 software menu structure, including the four main menus and the functions available from each menu.

Refer to this menu structure when using direct numeric entry to quickly access menus and programming functions.

1. CALIBRATION MODE

- 1.1 OPTICS VERIFY
- 1.2 MANUAL K-FACTOR
- 1.3 CAL CURRENT LOOP
- 1.4 TUNE CURRENT LOOP

2. REVIEW MODE

- 2.1 ALARM HISTORY
- 2.2 FAULT HISTORY
- 2.3 CURRENT TWA
- 2.4 LAST POWER DOWN
- 2.5 CUSTOMER DATA
- 2.6 PRINT CONFIG
- 2.7 INST SERIAL #
- 2.8 PRINT MENU

3. SET-UP MODE

- 3.1 POINT ENABLE
- 3.2 POINT PARAMETERS
- 3.3 OUTPUT OPTIONS
 - 3.3.1 COM PORT
 - 3.3.2 PRINTER PORT
 - 3.3.3 PRINTER FORMAT
 - 3.3.4 RELAY STATE
 - 3.3.5 2 mA FAULT OPER
 - 3.3.6 EN/DIS DUTY CYCLE
- 3.4 CONFIGURATION
- 3.5 DATE & TIME
 - 3.5.1 DATE FORMAT
 - 3.5.2 SET DATE & TIME
 - 3.5.3 SET DISPLAY CYCLE
 - 3.5.4 SET TWA TIME

- 3.5.5 SET IDLE TIME
- 3.5.6 SET DUTY CYCLE
- 3.6 ACCESS SETUP
 - 3.6.1 EN/DIS KBD LOCK
 - 3.6.2 EN/DIS MENU PASSWD
 - 3.6.3 SET PASSWORD
- 3.7 MAINT SET-UP
 - 3.7.1 CHEMCASS CTR
 - 3.7.2 INT FILT. LIFETIME
 - 3.7.3 EXT FILT. LIFETIME

4. SERVICE MODE

- 4.1 RELAY/LED TEST
- 4.2 ALARM TESTS
 - 4.2.1 ALM INDICATOR TEST
 - 4.2.2 SIMULATED ALM TEST
 - 4.2.3 OPTICS ALM TEST
- 4.3 DIAGNOSTICS
 - SOFTWARE VERSION AND KERNEL
 - GAS TABLE VERSION
 - FIRMWARE CHECKSUMS
 - REAL-TIME RAW OPTICS COUNTS
 - TAPE WINDOWS REMAINING
 - REAL-TIME POSITION OF TAPE AND COUNT OF EXTRA WINDOWS PULLED
 - POWER SUPPLY VOLTAGES
 - OPTICS DAC DRIVE VALUES
 - Q CALIBRATION FACTORS
 - FLOW TRANSDUCER OFFSETS
 - FLOW TRANSDUCER COEFFICIENTS
 - NEURON ID OF LONWORKS INTERFACE (IF FITTED)
 - PUMP LIMIT SETTINGS
 - BAROMETRIC PRESSURE, OPTICS TEMP, AND INTERNAL TEMP
 - TIMESTAMP OF ERASURE OF FAULT AND ALARM HISTORIES
- 4.4 RESET SYSTEM
- 4.5 LOAD CHEMCASSETTE
- 4.6 SET FLOW
- 4.7 MDA SERVICE

4.7 Keypad Locking Feature

Purpose

The keypad locking feature prevents unauthorized personnel from entering any information into the CM4 keypad without knowledge of a five-digit password. Without the password, for example, it is impossible to reset faults, change alarm levels or set K-factors. The keypad lock cannot be defeated by cycling the power on and off.

NOTE:

If the password is lost or forgotten, contact Honeywell Analytics Service for assistance.

Instructions

Refer to [Section 7.7](#) to enable the keypad lock feature. By default it is disabled. Set the password to some desired value between 90000 and 99999.

The power LED in the lower right corner of the CM4 control panel indicates the status of the keypad. Steady green indicates the keypad is unlocked. Flashing yellow indicates it is locked.

To set the keypad locking feature:

1. Enter Monitor Mode by pressing MONITOR and waiting at least 10 seconds for the tape to advance.
2. Enter the five-digit password on the keypad with about one second delay between keystrokes.
3. Verify from the power LED that the new state of the keypad is as desired. The character display will not provide any indication of the change.

NOTE:

The keypad is unlocked by entering the password again.

5 Calibration Mode Functions

5.1 Introduction

Use the Calibration Mode to:

- Perform tests
- Make adjustments to Chemcassette Analyzer calibration

The Calibration Mode offers four functions:

1 CALIBRATION MODE

- 1.1 OPTICS VERIFY
- 1.2 MANUAL K-FACTOR
- 1.3 CAL CURRENT LOOP
- 1.4 TUNE CURRENT LOOP

The following is an overview of each of the four functions. The following sections describe each of these options in detail:

- 1.1 OPTICS VERIFY verifies proper operation of the Chemcassette optics system (see [Section 5.2](#))
- 1.2 MANUAL K-FACTOR permits entry of a new K-factor for each particular point (see [Section 5.3](#))
- 1.3 CALIBRATE CURRENT LOOP controls the optional external analog output for testing and installation (see [Section 5.4](#))
- 1.4 TUNE CURRENT LOOP controls the adjustment of the CM4 monitor's output level (see [Section 5.5](#))

5.2 Function 1.1 – Optics Verify

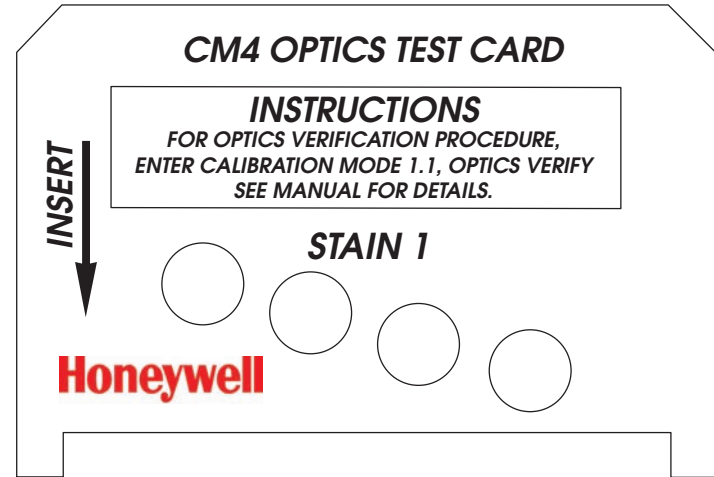

Figure 5-2: Verification Card

Purpose

Use the Optics Verify function and the Optics Verification Card to verify proper operation of the Chemcassette Analyzer's optics system. The CM4 compares the nominal stain values stored in the instrument's memory to the values the Optics Verification Card produces.

Instructions

1. Press PROGRAM to exit Monitor Mode.
2. From the 1–CALIBRATION MODE, choose the subfunction 1–OPTICS VERIFY.

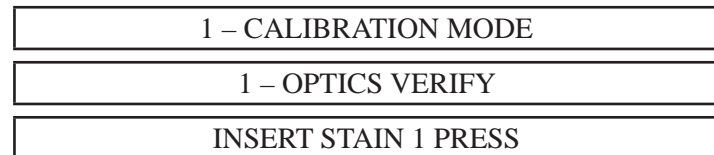

3. Open the tape load lever and remove the carrier. (See [Figure 9-1](#).)
4. Insert the verification card into the detector head with Stain 1 facing the front of the CM4. Make sure that Stain 1 is fully inserted into the detector head.
5. Carefully close the tape load lever.
6. Press CURSOR ARROW RIGHT on the numeric keypad. The readings for Stain 1 are stored. The display reads:

INSERT STAIN 2 PRESS ►

7. Open the tape load lever.
8. Remove the verification card.
9. Turn the card and fully insert Stain 2.
10. Carefully close the tape load lever.
11. Press CURSOR ARROW RIGHT.

The display shows one of two messages:

VERIFY SUCCESSFUL

or

F24 OPTICS FAIL

12. Open the tape load lever and remove the verification card.

If the optics verification is not successful, repeat the procedure if it not successful after the second test, see [Section 9.5](#), Cleaning the Chemcassette Optics. Once the cleaning is complete, repeat the optics verification procedure. Contact Honeywell Analytics if the instrument prints and displays the error message after a second optics verification attempt.

13. Reinstall carrier and close tape load lever.

Press RESET to return to the Calibration main menu.

5.3 Function 1.2 – Manual K-Factor

NOTE:

Some local fire ordinances require certified calibration at installation or annual intervals. While dynamic calibration is not required for proper operation of the Model CM4, Honeywell Analytics offers an optional Z-Cal calibration program which can quickly and safely satisfy your local needs. Contact Honeywell Analytics' Service department for this service.

NOTE:

For detailed instructions on gas calibration, refer to *Technical Note 971092, "Gas Verification of Chemcassette Monitors."*

The Manual K-factor adjusts the calculated concentration of a CM4 point. The K-factor is set at 1.000 for all gases during factory gas calibration. Change the factor only if the instrument's concentration readings do not match that of a known calibration gas.

Use a test gas of known concentration and at ambient humidity when using this function to re-calibrate the CM4.

A K-factor is the numeric result of a formula used to adjust the CM4 output of gas concentrations. The K-factor may be used to change the sensitivity of the instrument. Adjustments to concentration are made after calculation of concentration, and before the following are determined:

Display	Serial output
Optional current loop (4-20 mA)	Exceeding alarm level

The factory-set K-factor is 1.000 for all gases.

To calculate a new K-factor, use the following formula:

$$K = \frac{\text{True Concentration Value of Test Gas}}{\text{CM4 Reading}}$$

WARNING

Use appropriate safety precautions when handling toxic gases.
Properly vent toxic gases.

NOTE:

K-factors should be 1.000 unless actual gas calibration procedures are performed.

Instructions

1. Press PROGRAM to exit Monitor Mode.
2. From the 1–CALIBRATION MODE, choose the subfunction 2–MANUAL K-FACTOR.

1 – CALIBRATION MODE

2 – MANUAL K-FACTOR

The display now shows:

SELECT POINT

3. Use the numeric keys to specify the point. The display shows the current K-factor:

PT 1 K-FACTOR = 1.000

4. Use the numeric keys to enter the new K-factor.
5. Press either:
 - ENTER to save the new entry and return to the Calibration Mode
 - or
 - RESET to return to the Calibration Mode without changing any data

Repeat Steps 1 through 5 to adjust the calculated concentration for each point, if required.

K-factor range limits are 0.200 to 5.000. Using a value outside of these limits displays the following, after which the CM4 returns to the previous display:

OUT OF LIMITS

PT 1 K-FACTOR = 1.000

5.4 Function 1.3 – Calibrate Current Loop

Purpose

The Calibrate Current Loop function calibrates the external analog devices connected to the module by generating a 2 mA to 20 mA analog signal from each individual point. If 2 mA fault indication is disabled via menu function 3.3.5, then the minimum current will change from 2 mA to 4 mA. This function provides three methods to calibrate connected devices:

- Toggling between 2 mA, 4 mA, and 20 mA signal levels
- Automatically changing output signal levels beginning at 2 mA and going up to 20 mA
- Step up the current loop from 4 mA to 20 mA in 1 mA increments.

5.4.1 Selecting the Signal Levels Manually

Purpose

The Calibrate Current Loop function allows selection of the signal level for each individual point.

Instructions

1. Press PROGRAM to exit Monitor Mode.
2. From the 1–CALIBRATION MODE, choose CALIBRATION MENU, then the subfunction 3–CALCULATE CURRENT LOOP.

1 – CALIBRATION MODE

CALIBRATION MENU <>

3 – CAL CURRENT LOOP

The display reads:

SELECT POINT

3. Use the numeric keys to specify a point. The screen displays:

PT 1 CAL 1=MAN 2=RAMP 3=STEP

4. Press 1. The selected output point drops automatically to 2 mA or remains at 4 mA, depending on whether 2 mA fault operation is set (see [Section 7.4.5](#)). The display reads:

PT 1 2 mA PRESS ► 20 mA

5. Press CURSOR ARROW RIGHT to toggle the output between 2 mA to 20 mA. The display reads:

PT 1 20 mA PRESS ► 2 mA

Press RESET to return to the Calibration Mode without toggling the test levels.

5.4.2 Selecting Signal Levels – Automatic Ramping

1. Press PROGRAM to exit Monitor Mode.
2. From the 1–CALIBRATION MODE, choose CALIBRATION MENU, then the subfunction 3–CALIBRATE CURRENT LOOP.

1 – CALIBRATION MODE

CALIBRATION MENU <>

3 – CAL CURRENT LOOP

The display reads:

SELECT POINT

3. Use the numeric keys to specify a point. The displays reads:

PT 1 CAL 1=MAN 2=RAMP 3=STEP

4. Press 2. The display shows the output for the selected point, beginning at 2 mA, then 4 mA, 8 mA, 12 mA, 16 mA, and ending at 20 mA. Each output level is displayed 5 seconds. The display reads:

PT 1 RAMP = 2 mA

PT 1 RAMP = 4 mA

PT 1 RAMP = 8 mA

PT 1 RAMP = 12 mA

PT 1 RAMP = 16 mA

PT 1 RAMP = 20 mA

The CM4 repeats the sequence showing level of output, from 4 mA to 20 mA (or 2 mA to 20 mA if selected). Press RESET twice to return to the Calibration Mode.

5.4.3 Selecting Signal Levels – Step

1. Press PROGRAM to exit Monitor Mode.
2. From the 1–CALIBRATION MODE, choose CALIBRATION MENU, then the subfunction 3–CALIBRATE CURRENT LOOP.

1 – CALIBRATION MODE

CALIBRATION MENU <>

3 – CAL CURRENT LOOP

The display reads:

SELECT POINT

3. Use the numeric keys to specify a point. The displays reads:

PT 1 CAL 1=MAN 2=RAMP 3=STEP

4. Press 3. The display shows the output for the selected point, which will be set at 4 mA, whether or not a 2 mA fault operation is enabled. The current loop can be lowered (decremented) to 20 mA if a 2 mA fault indication is enabled.

You are able to use the arrow keys to adjust the current loop from 4 mA to 20 mA in 1 mA increments. The display reads:

PT 2 CURR = 04 mA

PT 2 CURR = 07 mA

Press RESET twice to return to the Calibration MENU.

5.5 Function 1.4 – Tune Current Loop

Purpose

The Tune Current Loop function allows you to adjust the CM4 monitor's output level so that it is correlated from zero to full scale with a driven device (an instrument used to monitor 4-20 mA output).

This is necessary only if new current loop hardware has been field installed.

Instructions

To access Tune Current Loop:

1. Press PROGRAM to exit the Monitor Mode.
2. From the 1–CALIBRATION MODE, choose the subfunction 4–Tune Current Loop, then SELECT POINT.

1 – CALIBRATION MODE

4 – TUNE CURRENT LOOP

BOARD NOT FOUND

This message is displayed on newer CM4s if the optional current output board is absent or defective.

LOAD DEFAULT 1=Y 0=N

This message is displayed only on newer CM4s. If “1” is chosen then the factory calibration parameters will be loaded.

4 mA = 712

The user may change the DAC endpoint value corresponding to 4 mA by pressing the arrow keys. However this should not be performed without a known accurate external ammeter and Technical Note T/N 1988-0040. Press <ENTER> to proceed.

20 mA = 3750

Similarly, this permits changing the 20 mA DAC endpoint. Press <ENTER> to proceed.

SELECT POINT

The above procedure should be repeated for all four points.

6 Review Menu Functions

6.1 Introduction

The Review Menu contains eight functions which permit viewing data. It is not possible to change the CM4 configuration with these functions.

2 REVIEW MENU	
2.1	ALARM HISTORY
2.2	FAULT HISTORY
2.3	CURRENT TWA
2.4	LAST POWER DOWN
2.5	CUSTOMER DATA
2.6	PRINT CONFIGURATION
2.7	INST. SER. NUMBER
2.8	PRINT MENU

Figure 6-1: Review Mode Menu

The following is an overview of each of the eight options. The following sections describe each of these options in detail:

- 2.1 ALARM HISTORY displays and prints up to 16 gas alarms with the most recent alarm shown first (see [Section 6.2](#))
- 2.2 FAULT HISTORY displays and prints up to eight faults with the most recent shown first (see [Section 6.3](#))
- 2.3 CURRENT TWA displays and prints the current Time Weighted Average (TWA) for each point that has been monitored since the start of the current 8-hour TWA (see [Section 6.4](#))
- 2.4 LAST POWER DOWN displays the most recent power-down and power-up date and time (see [Section 6.5](#))
- 2.5 CUSTOMER DATA displays customer name and location (see [Section 6.6](#))

- 2.6 PRINT CONFIGURATION prints the programmed configuration for the system (see [Section 6.7](#))
- 2.7 INST. SER. NUMBER displays CM4 serial number (see [Section 6.8](#))
- 2.8 PRINT MENU prints the CM4 menu options (see [Section 6.9](#))

6.2 Function 2.1 – Alarm History

Use the alarm history function to print or display up to a maximum of 16 gas alarms with the most recent alarm shown first.

6.2.1 Print Alarm History

If the CM4 is equipped with a printer, see [Figure 6-2](#) for an example of a typical alarm history printout.

Purpose

The printout of the alarm history shows the most recent alarm first for up to 16 total alarms. The printout shows:

- Instrument serial number
- Current date and time
- Customer name and location
- Point number
- Alarm date and time
- Concentration in ppb or ppm
- Alarm levels

Instructions

1. Press PROGRAM to exit Monitor Mode.
2. At the REVIEW MENU display, press 1 or RIGHT ARROW and ENTER to select alarm history.

The display reads:

1 – ALARM HISTORY

- Use the numeric keys to specify a point, or press ENTER to select the alarm history of all monitored points.

The display briefly shows:

ALM HISTORY ALL PTS

or

PT 1 ALARM HISTORY

The display then reads (for both):

1 = DISPLAY 2 = PRINT

- Press 2 to print the alarm history.

The CM4 sends the alarm history to the printer.

```
05/15/98 09:46 CM4-851-0000 ALM HISTORY ALL POINTS
ABC MANUFACTURING CO., CHICAGO, IL

PT1 CM4-851-0000
NO ALARM HISTORY

PT2 CM4-851-0000
05/15/98 08:33 LEVEL 1 ALARM 27.8 PPM NH3-II
05/14/98 08:42 LEVEL 1 ALARM 27.6 PPM NH3-II

PT3 CM4-851-0000
NO ALARM HISTORY

PT-4-CM4-851-0000
NO ALARM HISTORY

END OF ALARM HISTORY
```

Figure 6-2: Typical Alarm History Printout

Alarm history is not cleared using the RESET key. The display returns to normal after ten seconds.

Press RESET to return to the Review Menu.

6.2.2 Display Alarm History

Purpose

The alarm history display shows alarm:

- Point number
- Concentration
- Time
- Level

Instructions

- Press PROGRAM to exit Monitor Mode.
- At the REVIEW MENU display, press 1 or CURSOR RIGHT ARROW.

The display reads:

1 – ALARM HISTORY

- Use the numeric keys to specify a point, or press ENTER to select the alarm history of all monitored points.

The display briefly shows:

ALM HISTORY ALL PTS

or

PT 1 ALARM HISTORY

The display then reads (for both):

1 = DISPLAY 2 = PRINT

- Press 1 to display the alarm history.

The CM4 stores up to 16 alarms. Press CURSOR ARROW LEFT/RIGHT to scroll through the list of alarms. The CM4 displays date, time, point number, concentration, gas and alarm level.

- Press either:

- The CURSOR ARROW LEFT/RIGHT to scroll the display

forward/backward to the next/previous event stored
or

- ENTER to re-scroll the event just displayed

PT 1 56 PPB ASH3

12/27/95 09:31 L2 ►

Alarm history is not cleared using the RESET key.

Press RESET to return to the Review menu.

6.3 Function 2.2 – Fault History

Use the fault history function to print and display the eight most recent faults and alarms.

6.3.1 Print Fault History

See **Figure 6-3** for a typical example of a fault history printout.

Purpose

The printout of the fault history shows the most recent fault first for up to eight total faults. The printout includes:

- Instrument serial number
- Current date and time
- Customer name and location
- Fault number (FXX)
- Fault type
- Fault date and time

Instructions

1. Press PROGRAM to exit Monitor Mode.
2. From the 2–REVIEW MENU, choose the subfunction 2–FAULT HISTORY.

2 – REVIEW MODE

2 – FAULT HISTORY

The display reads:

1 = DISPLAY 2 = PRINT

3. Press 2 to print the fault history.

The CM4 sends the fault history to the printer.

08/26/05 13:51 CM4-851-0000 FAULT HISTORY ABC MANUFACTURING CO., CHICAGO, IL			
08/26/05	10:34	F12	END OF CASSETTE
08/25/05	09:15	F8	Chemcassette SUPPLY LOW
07/26/05	08:33	F9	GATE OPEN DURING MONITOR
06/21/05	15:50	F15	FLASH CARD ERROR

Figure 6-3: Typical Fault History Printout

Fault history is not cleared using the RESET key.

6.3.2 Display Fault History

Purpose

The fault history display shows fault:

- Number
- Name
- Date and time

Instructions

1. Press PROGRAM to exit Monitor Mode.
2. From the 2–REVIEW MENU, choose the subfunction 2–FAULT HISTORY.

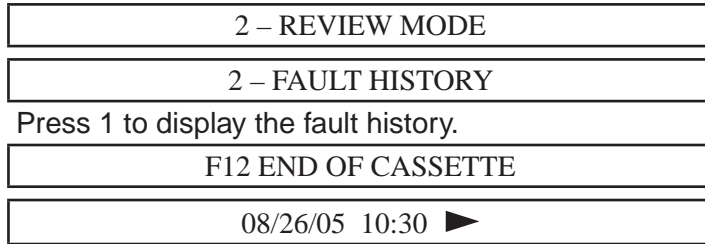

3. Press 1 to display the fault history.

The display shows the last eight faults stored in fault history.

4. Press either:

- CURSOR ARROW LEFT/RIGHT to scroll forward/backward to the next/previous event stored
or
- ENTER to repeat the event just displayed

Fault history is not cleared using the RESET key. Press RESET to return to the Review Menu.

6.4 Function 2.3 – Current TWA

Use the Current TWA (Time Weighted Average) function to display or print the current TWA for each point monitored since the start of the current 8-hour TWA. The TWA is the concentration of gas measured and averaged over the entire period.

6.4.1 Print TWA

See [Figure 6-4](#) for an example of a typical TWA printout.

Purpose

The printout of the TWA shows:

- Instrument serial number
- Current date and time
- Customer name and location
- Start and end time

- Elapsed time
- Concentration levels for each point

Instructions

1. Press PROGRAM to exit Monitor Mode.
2. From the 2–REVIEW MENU, choose the subfunction 3–CURRENT TWA.



The display reads:



3. Press 2 to print the TWA history.

The CM4 calculates and prints TWA information based upon the elapsed time (maximum of 8 hours) from the last entry into Monitor Mode, power-up, or completed TWA printout until the last sample prior to leaving Monitor Mode.

08/26/05 13:51 CM4-851-0000 TWA			
ABC MANUFACTURING CO., CHICAGO, IL			
START TIME:		08/26/05	03:56
END TIME:		08/26/05	11:26
ELAPSED TIME:		7 HOURS 30 MINUTES	
POINT 1	GASCAB	16 PPB	AsH3
POINT 2	VALVEBOX	8 PPB	AsH3
POINT 3	OPZONE	0 PPB	AsH3
POINT 4	EXHDUCT	0 PPB	AsH3

Figure 6-4: TWA Printout

6.4.2 Display TWA

Purpose

The Current TWA display shows:

- Current TWA start time
- Current TWA end time
- Elapsed time
- Concentration levels for each point

Instructions

1. Press PROGRAM to exit Monitor Mode.
2. From the 2-REVIEW MENU, choose the subfunction 3-CURRENT TWA.

```
2 - REVIEW MODE
```

```
3 - CURRENT TWA
```

The display reads:

```
1 = DISPLAY 2 = PRINT
```

3. Press 1 to display the TWA information.
4. Press CURSOR ARROW LEFT/RIGHT to scroll forward/backward to the next/previous display.

```
START 08/26/05 03:56
```

```
END 08/26/05 11:26
```

```
ELAPSED 07HRS 30MIN
```

The display shows, in sequence beginning at point 1, accumulated concentrations for all four points.

Press RESET to return to the Review Menu.

6.5 Function 2.4 – Last Power-Down

Use the last power-down function to print and display the most recent power-down and power-up date and time.

Purpose

Last power-down information which the CM4 prints and displays includes:

- Instrument serial number
- Current date and time
- Date and time power was interrupted
- Date and time power was restored

6.5.1 Print Last Power-Down

See **Figure 6-5** for an example of a typical last power-down function printout.

Instructions

1. Press PROGRAM to exit Monitor Mode.
2. From the 2-REVIEW MENU, choose the subfunction 4-LAST POWER DOWN.

```
2 - REVIEW MODE
```

```
4 - LAST POWER DOWN
```

The display reads:

```
1 = DISPLAY 2 = PRINT
```

3. Press 2 to send the information to the printer.

```
CM4-851-0000
08/26/05 10:22
POWER INTERRUPTED 05/26/05 10:15
POWER RESTORED 06/01/05 07:30
```

Figure 6-5: Typical Last Power-Down Printout

The CM4 also prints this information when power is restored after a power loss.

6.5.2 Display Last Power-Down

Purpose

The display last power-down function displays the same information for the last power-down as is sent to the printer, described in the previous section.

Instructions

1. Press PROGRAM to exit Monitor Mode.
2. From the 2–REVIEW MENU, choose the subfunction 4–LAST POWER DOWN.

2 – REVIEW MODE

4 – LAST POWER DOWN

The display reads:

1 = DISPLAY 2 = PRINT

3. Press 1 to display the last power-down information.

PWRDN 05/26/05 10:15

PWRUP 06/01/05 07:30

The display alternates the power-down/power-up messages until RESET is pressed.

6.6 Function 2.5 – Customer Data

Use the customer data function to print and display information about the customer. Honeywell Analytics programs and stores the customer name and location in the CM4. This information is included in TWA and other printouts.

6.6.1 Print Customer Data

Purpose

The CM4 prints the following customer information:

- Name
- Location

Instructions

1. Press PROGRAM to exit Monitor Mode.
2. From the 2–REVIEW MENU, choose the subfunction 5–CUSTOMER DATA.

2 – REVIEW MODE

5 – CUSTOMER DATA

The display reads:

1=DISPLAY 2=PRINT

3. Press 2 to print the customer name and location.

6.6.2 Display Customer Data

Purpose

Use the Display Customer Data function to display the same information about the customer as is sent to the printer, described in the previous section.

Instructions

1. Press PROGRAM to exit Monitor Mode.
2. From the 2–REVIEW MENU, choose the subfunction 5–CUSTOMER DATA.

2 – REVIEW MODE

5 – CUSTOMER DATA

The display reads:

1 = DISPLAY 2 = PRINT

3. Press 1 to display the customer data. Press 1 again to alternate between the two lines of customer data.

ABC MANUFACTURING

CHICAGO, ILL

Press RESET to return to the Review Menu

6.7 Function 2.6 – Print Configuration

Purpose

Use the Print Configuration function to print the preprogrammed system configuration, including:

- Serial number
- Customer name and location
- Date and time
- All configuration information

See [Figure 6-6](#) for a typical printout.

The CM4 only prints the data. Data is not displayed.

Instructions

1. Press PROGRAM to exit Monitor Mode.
2. From the 2–REVIEW MENU, choose the subfunction 6–PRINT CONFIGURATION.

2 – REVIEW MODE

6 – PRINT CONFIG

Use the Set-Up Menu to change any configurable parameters shown on the printout (see [Section 7](#)).

The CM4 prints the system configuration information, shown on the sample printout in [Figure 6-6](#).

6.8 Function 2.7 – Instrument Serial Number

Purpose

Use the Instrument Serial Number function to display the CM4 serial number. Being able to display the instrument serial number avoids the necessity of looking behind the instrument to retrieve the serial number when placing a call to Honeywell Analytics for information or service. It is always a good idea to write the serial number and file it for future reference. This information appears in TWA and other printouts.

Instructions

1. Press PROGRAM to exit Monitor Mode.
2. From the 2–REVIEW MENU, choose the subfunction 7–INSTRUMENT SERIAL NUMBER.

2 – REVIEW MODE

7 – INST. SER. NUMBER

The display shows the instrument serial number:

SERIAL #851-0000

Press RESET to return to the Review Menu.

For the CM4-P, the letter “P” replaces the hyphen used in standard CM4 serial numbers, i.e. 851P000X for a CM4-P instrument, and 851-000X is a standard CM4 serial number. This designation appears on all printouts, point IDs, and displays in which the instrument identification is used.

```

5/15/05 10:06 CM4-851-0000                                SYSTEM CONFIGURATION PRINTOUT
                                ABC MANUFACTURING CO., CHICAGO, IL.
Chemcassette:          Hydrides
NAME                   ABBREVIATION
ARSINE                  AsH3
PHOSPHINE               PH3
SILANE                  SiH4
DIBORANE                B2H6
TERTIARYBUTYLARSINE   TBA
HYDROGEN SULFIDE       H2S
DRY ARSINE              AsH3/D
HYDROGEN SELENIDE     H2Se
NAME                   GAS          K-FACTOR    ALARM 1      ALARM 2      20 mA FS     ENABLE
PT1-CM4-851-0006      AsH3        1.000       50ppb        100ppb       500ppb       YES
PT2-CM4-851-0006      AsH3        1.000       50ppb        100ppb       500ppb       YES
PT3-CM4-851-0006      AsH3        1.000       50ppb        100ppb       500ppb       YES
PT4-CM4-851-0006      AsH3        1.000       50ppb        100ppb       500ppb       YES
RELAY STATE.....    LATCHING .....DE-ENERGIZED
2 mA FAULT INDICATION.....DISABLED
PUMP LIMITS.....    .500, 400
DISPLAY UPDATE TIME.....4 SECONDS
TWA PRINT TIMES.....00:00, 08:00, 16:00
PRINTER PORT.....    9600 BAUD
HAND SHAKE.....      DISABLED
PRINTOUT SELECTED.....COMPRESSED
IDLE TIMEOUT.....    45 MINUTES
DUTY CYCLE 000 SECONDS.....POINTS LINKED TO MONITOR RELAY (1, 2, 3, 4)
SERVICE HISTORY.....
INT. FILTER LIFE .....0 DAYS
EXT. FILTER LIFE .....0 DAYS
Chemcassette REMAINING.....0 DAYS
LAST OPTICS VERIFICATION:.....05/15/05 10:06
LAST FLOW BALANCE:.....05/15/05 10:06
COM PROTOCOL VERSION 1.....ADDRESS OO1. 9600 BAUD
KEYBOARD LOCK.....    DISABLED
MENU PASSWORD.....    DISABLED
DATE FORMAT.....      MM/DD/YY
TAPE ADVANCE SENSOR.....128P.....STATUS 04CF 68A7 4846
END OF SYSTEM CONFIGURATION PRINTOUT*****
    
```

Figure 6-6: Typical Configuration Printout

6.9 Function 2.8 – Print Menu

Purpose

Use the Print Menu function to print a list of CM4:

- Menu options
- Functions available from each menu

Instructions

1. Press PROGRAM to exit Monitor Mode.
2. From the 2–REVIEW MENU, choose the subfunction 8–PRINT MENU.

2 – REVIEW MODE

8 – PRINT MENU

The CM4 prints a complete listing of the master menu. See [Section 4.6](#) for an example.

If the printer is not enabled or a printer fault occurs, the CM4 displays the following:

PRINTER DISABLED

Correct the fault and repeat Steps 1 and 2.

See [Section 7.4.2](#) to enable the printer.

7 Setup Menu

7.1 Introduction

Use the Set-Up Menu to:

- Configure the CM4
- Program monitoring sequences and parameters

The Set-Up Menu offers seven primary functions (see Figure 7-1).

7.1.1 Enabling/Disabling the Keypad

The CM4 includes a function that allows enabling and disabling of the keypad. The function toggles between enabling and disabling the keypad when a passcode is entered via the keypad.

NOTE:

The keypad enable function and all passcodes begin with “9” number.

The keypad locking feature is disabled by default. However, it may be enabled by setup function 3.6.1

While in the Monitor Mode, entering the proper passcode toggles between the keypad lock and unlock conditions. The factory-set default is 90000.

For all subsequent CM4 operation, you must use a passcode to change between keypad lock and unlock (i.e., enabled and disabled). For passcode information, refer to [Section 7.7](#).

3	SET-UP MODE
3.1	POINT ENABLE
3.2	POINT PARAMETERS
3.3	OUTPUT OPTIONS
3.3.1	COM PORT
3.3.2	PRINTER PORT
3.3.3	PRINTER FORMAT
3.3.4	RELAY STATE
3.3.5	2mA FAULT OPER
3.3.6	EN/DIS DUTY CYCLE
3.4	CONFIGURATION
3.5	DATE & TIME
3.5.1	DATE FORMAT
3.5.2	SET DATE & TIME
3.5.3	SET DISPLAY CYCLE
3.5.4	SET TWA TIME
3.5.5	SET IDLE TIME
3.5.6	SET DUTY CYCLE
3.6	ACCESS SETUP
3.6.1	END/DIS KBD LOCK
3.6.2	EN/DIS MENU PASSWD
3.6.3	SET PASSWORD
3.7	MAINT. SET-UP
3.7.1	CHEMCASS CTR
3.7.2	INT. FILTER LIFETIME
3.7.3	EXT. FILTER LIFETIME

Figure 7-1: Set-Up Menu

The following is an overview of each of the seven functions. The following sections describe each of these functions in detail:

- 3.1 POINT ENABLE disables points not needed (see Section 7.2)
- 3.2 POINT PARAMETERS configures points, selects gas type, alarm level, and 20 mA full scale, as well as assigns each point an identification (see [Section 7.3](#))
- 3.3 OUTPUT OPTIONS enables the Printer and COM outputs and defines data format between data transmissions and determines relay state and 2mA fault operational status (see [Section 7.4](#))
- 3.4 CONFIGURATION saves a new instrument configuration or restores a previously saved instrument configuration (see [Section 7.5](#))
- 3.5 DATE & TIME controls several date and time functions (see [Section 7.6](#))
- 3.6 ACCESS KEYLOCK locks the keypad from unauthorized access when in Monitor Mode (see [Section 7.7](#))
- 3.7 MAINT. SET-UP enables and disables the Chemcassette® and internal/external filter counters (see [Section 7.8](#)). See [Section 8.6](#) to reset Chemcassette® and filter counters.

7.2 Function 3.1 – Point Enable

Purpose

Use the Point Enable function to disable points not needed.

Instructions

1. Press PROGRAM to exit Monitor Mode.
2. From the 3–SET-UP MENU, choose the subfunction 1–POINT ENABLE.

The display reads:

```
SELECT POINT
```

3. Select Point 1.

The display reads:

```
PT1 ENABLE 1=Y 0=N
```

4. Enter your selection, “1” or “0”.

The display returns to:

```
SELECT POINT
```

5. Press RESET to return to the Set-Up Menu.

NOTE:

Disabling a point will not activate any alarm or set any output concentrations for that point.

7.3 Function 3.2 – Point Parameters

Purpose

Use the Point Parameters function to:

- Specify gases for monitoring
- Set alarm levels and current loop Full Scale (FS) value for each point
- Assign point identification strings

7.3.1 Select Gas Type, Program Alarms and Set Current Loop Full Scale Values

Instructions

1. Press PROGRAM to exit Monitor Mode.
2. From the 3–SET-UP MENU, choose subfunction 2–POINT PARAMETERS.

3 – SET-UP MENU

2 – POINT PARAMETERS

The display reads:

SELECT POINT

3. Use the numeric keys to specify the point you wish to configure, or press RESET to exit this function.

If the printer output is enabled, the display reads:

PRINT? 1=YES 0=NO

The printout helps to determine which point parameters to change. If, for example, you selected point 1 (pressed 1) in Step 3, the printer prints the parameters and the display briefly reads:

POINT 1 SELECTED

The status LED blinks for the point selected

The display changes to:

1=GAS/LEVELS 2=PT ID

4. Press 1 to:
 - Select a gas type
 - Program the Level 1 and Level 2 alarms
 - Set the full scale value of the 20 mA output.

Press 2 to define the point identification. See [Section 7.3.2](#).

Upon pressing 1 the display reads:

PT 1 GAS AsH3 ◀▶

5. Press the CURSOR ARROW LEFT/RIGHT to scroll through the available gases. See [Appendix C](#) for a list of values.

WARNING

Make sure the gas assignment is correct when entering designations for specific gases within a gas family (such as Hydrides or Mineral Acids); the instrument will not show an error prompt for the wrong gas (e.g., if you select HF rather than HCl). Incorrect gas assignment or Chemcassette® replacement defeats the CM4's ability to warn of dangerous gas concentrations.

Be sure you have installed the proper Chemcassette® in the analyzer for the type of gas being measured; the CM4 will not show an error prompt for installation of an incorrect type of Chemcassette®.

6. Press ENTER to select the desired target gas. The following display will appear briefly:

SET ALARM LEVELS

The display will then read:

L1 = 0050 PPB AsH3

Both Level 1 and Level 2 alarms must be set. The cursor flashes over the alarm value.

7. Use the numeric keypad to set the Level 1 alarm value (lower alarm level) for the chosen gas. Press ENTER to accept the value and advance to the following display:

L2 = 100 PPB AsH3

The cursor flashes over the alarm value.

8. Use the numeric keypad to set the Level 2 alarm value (upper alarm level) for the chosen gas.

NOTE:

The unit will record any changes if Level 1 is set higher than Level 2 or if Level 1 and/or Level 2 are set outside the gas alarm ranges (see [Appendix C](#)). Re-enter the values until the parameters are acceptable.

9. Press ENTER to accept the value and advance to the display prompt used to set the current loop Full Scale values:

20 mA = 500 PPB

Setting the current loop Full Scale values applies to the 4-20 mA current loop. To select the 2 mA fault indication, see Section 7.4.5.

The display reads:

20 mA = 500 PPB

The cursor flashes over the Full Scale (FS) value.

10. Press CURSOR ARROW LEFT/RIGHT and numeric keys to enter the desired full scale value.
11. Press ENTER to accept the value and advance to the following display:

1=GAS/LEVELS 2=PT ID

or

Press RESET to select another point. The display reads:

SELECT POINT

The flashing status LED stops. Press RESET again to display the print prompt:

PRINT? 1=YES 0=NO

12. Repeat Steps 4 through 11 to set the gas type and alarm for the remaining three points.
13. After programming the chosen points, press ENTER to accept the values. The display reads:

1=GAS/LEVELS 2=PT ID

Press 2 to define the point identification (see [Section 7.3.2](#)).

7.3.2 Defining the Point ID

This feature permits changing the default point ID label to a more informative string. The name will be displayed on the front panel display during monitor mode.

Instructions

1. Press PROGRAM to exit Monitor Mode.
2. From the 3-SET-UP MENU, choose the subfunction 2-POINT PARAMETERS.

3 - SET-UP MODE

2 - POINT PARAMETERS

The display reads:

SELECT POINT

3. Use the numeric keys to specify the point you wish to configure, or press RESET to exit this function.

If printer output is enabled, the display reads:

PRINT? 1=YES 0=NO

The printout helps to determine which point parameters to change. If, for example, you selected point 1 (pressed 1) in Step 3, the printer prints the parameters and the display briefly reads:

POINT 1 SELECTED

The corresponding point status LED blinks.

The display changes to:

1=GAS/LEVELS 2=PT ID

4. Press 2 to define the point identification.

The display briefly reads:

PROGRAM RESET

The display then shows the default ID:

PT1—CM4—851—0000

The “PT1-” portion of the above display indicates the point ID and therefore cannot be changed. You can program up to 16 total characters, starting at the C. Example: “PT1-NORTH-CAB”

NOTE:

The default ID does not use the full length of 16 characters.

5. Press PROGRAM to scroll up or RESET to scroll down through the 46-character alpha, numeric, and symbols shown here:
 - [SPACE] 0123456789
 - ABCDEFGHIJKLMNOPQRSTUVWXYZ
 - _ -) (# / . ,
6. When the correct character appears, use CURSOR ARROW LEFT/RIGHT to select the next space.
7. Press ENTER to save the configuration, turn off the blinking LED for the specific point, and return to:

1=GAS/LEVELS 2=PT ID

The point ID changed message is printed.

Press RESET to return to the display:

SELECT POINT

Press RESET again and then press 1 to print the new configuration and the date and time of change if the printer is enabled, or press 0 to return to the Set-Up Menu.

8. To define the remaining points, repeat Steps 3 through 7 when the display in Step 7 reads:

SELECT POINT

7.4 Function 3.3 – Output Options

Use the output options function to specify parameters for:

- COM port
- Printer port
- Printer format

Also use this function to determine:

- Relay state
- 2 mA fault operational status
- EN/DIS duty cycle

7.4.1 Optional COM Port (3.3.1)

Purpose

Use the COM port function to enable the optional communication port and specify the baud rate for communication with the Network as either:

- 1200 baud
- 2400 baud
- 4800 baud
- 9600 baud
- 19200 baud

The default speed of 9600 baud is satisfactory for most installations.

The CM4 Communications Protocol is described in detail in [Appendix E](#).

Instructions

1. Press PROGRAM to exit Monitor Mode.
2. From the 3–SET-UP MENU, choose the subfunction 3–OUTPUT OPTIONS, then 1–COM PORT

3 – SET-UP MODE

3 – OUTPUT OPTIONS

1 – COM PORT

The display reads:

COM PROT VER 1

Other choices include:

COM PROT VER 2

COM PROT LONWORKS

and

COM PORT DISABLED

Refer to the CM4 Serial Communications Protocol Manual (P/N 1998M0020) for more information.

3. After making a selection, press ENTER. The display reads:

COM PORT = 9600 BAUD

4. Press CURSOR ARROW RIGHT to advance the display from 1200, 2400, 4800, 9600, to 19200 baud.
5. Press ENTER when the display shows the desired baud rate.

The display reads:

BAUD RATE UPDATED

The display reads:

INST. ADDRESS 001

6. Press ENTER after selecting the desired address. A unique address must be assigned to each CM4 sharing an RS 485 bus.

The display then returns to the output options function.

Press RESET to return to the Set-Up Menu.

7.4.2 Optional Printer Port (3.3.2)

Purpose

Use the printer port function to enable the optional communication port and specify the baud rate for communication with the Network as either:

- 1200 baud
- 2400 baud
- 4800 baud
- 9600 baud
- 19200 baud

Instructions

1. Press PROGRAM to exit Monitor Mode.
2. From the 3–SET-UP MENU, choose the subfunction 3–OUTPUT OPTIONS, then 2–PRINTER PORT.

3 – SET-UP MODE

3 – OUTPUT OPTIONS

2 – PRINTER PORT

The display reads:

PRINTER PORT = ENABLE

3. Press CURSOR ARROW RIGHT to toggle between enabling and disabling the printer port.
4. Press ENTER. The display reads:

PRINTER 9600 BAUD

5. Press CURSOR ARROW RIGHT to advance the display from 1200, to 2400, to 4800, to 9600, to 19,200 baud.
6. Press ENTER when the display shows the desired baud rate.

The display shows the baud rate selected:

BAUD RATE UPDATED

The display reads:

HW HANDSHAKE DISABLE

Use the cursor keys to toggle between enable and disable. Press ENTER.

7. Enable the handshake. The handshake, when enabled, indicates a printer time-out fault on the maintenance relay. The display reads:

HW HANDSHAKE ENABLE

This option enables RTS/CTS flow control on the printer output. The CM4 is not capable of Xon/Xoff flow control.

Press CURSOR ARROW LEFT or RIGHT to toggle between enable and disable. When the display shows ENABLE, press ENTER. The display will momentarily show:

HW HANDSHAKE ENABLED

NOTE:

HW Handshake is not used for RS-422 operation. No printer time-out is issued. If you are using RS-422 option (P/N 874023-F or 874023-R) choose DISABLE and then press ENTER.

The display then returns to the output options function. Press RESET to return to the instrument Set-up Menu. See [Appendix D](#) for additional information.

For multiple instrument installations, repeat [Section 7.4.2](#) for each CM4 monitor.

7.4.3 Printer Format (3.3.3)

Purpose

Use the printer format function to define the format of the printout.

Instructions

1. Press PROGRAM to exit Monitor Mode.
2. From the 3–SET-UP MENU, choose the subfunction 3–OUTPUT OPTIONS, then 3–PRINTER FORMAT.

3 – SET-UP MODE

3 – OUTPUT OPTIONS

3 – PRINTER FORMAT

The display reads:

SELECT REPORT

1=CONT 2=SUM 3=COMP

The cursor is flashing over the current set-up.

3. Select the type of report desired. Report contents are listed in [Table 7-1](#), use the numeric keys to select the type of report:
 - 1, for Continuous Mode (CONT), which sends all information to the printer, including point concentrations for every sample period, alarm and fault data, and the 8-hour TWA.
or
 - 2, for Summary Mode (SUM), which prints the alarm and fault data and the 8-hour TWA.
or
 - 3, for Compressed Mode (COMP), which prints all point concentrations that exceed the lowest detectable limit, alarm and fault data, and TWA information. This is the default setting. [Table 7-1](#) shows a summary matrix.

	Continuous	Summary	Compressed
Zero Readings	X		
Non-Zero Readings	X		X
Alarm Readings	X	X	X
Fault Readings	X	X	X

Table 7-1: Report Options

The display shows:

PRINT FORMAT UPDATED

- The CM4 automatically returns to the Output Options menu.

7.4.4 Relay State (3.3.4)

Purpose

Use the relay state function to:

- Select the state of the relay contacts to either energized or de-energized and latching or non-latching
- Set the alarms to nonlatching, which clears the alarm automatically (without pressing RESET) once the concentration decreases below the alarm level threshold or the fault is cleared

NOTE:

The default condition is de-energized for all relay contacts except the watchdog relay, which remains energized as a fail-safe precaution in the event of power loss.

Instructions

- Press PROGRAM to exit Monitor Mode.
- From the 3–SET-UP MENU, choose the subfunction 3–OUTPUT OPTIONS, then 4–RELAY STATE.

3 – SET-UP MODE

3 – OUTPUT OPTIONS

4 – RELAY STATE

The display reads:

SELECT RELAY STATE

The display then reads:

1=ENRGZD 0=DE-ENRGZD

The cursor is flashing over the current set-up.

- Press either:

- 1 to energize relay contacts
- or
- 0 to de-energize relay contacts.

Pressing 1 displays:

CONFIRM ENERGIZED

followed by the display:

1=ENRGZD 0=DE-ENRGZD

- Repeat Step 3 to confirm the entry. The relay state confirmation display reads:

RELAY DE-ENERGIZED

or

RELAY ENERGIZED



CAUTION

Selecting the energized state changes all relay states, except the watchdog. If power is lost, energized relays change state if they are selected to be energized. Be sure that this will not initiate a false alarm condition in your facility.

Once the relay state is selected, the display reads:

LATCHING RELAYS

The display then reads:

1=LATCHING 0=NON

The cursor is flashing over the current set-up.

5. Press either:

- 1 to select latching, which requires manual reset of alarms
- or
- 0 to select nonlatching, which clears an alarm automatically once the gas concentration falls below the alarm threshold.

The display shows the selection:

LATCHING SELECTED

or

NON LATCH'G SELECTED

The CM4 returns automatically to the Output Options menu.

7.4.5 2 mA Fault Operation (3.3.5)

Purpose

Use the 2 mA fault operation function to enable a 2 mA signal on the current loop that indicates when an instrument fault occurs. The CM4 differentiates between a power loss and a fault by dropping the signal to 0 mA after a power loss or CPU failure and 2 mA when an instrument fault occurs.

When enabled, the fault operation function causes the calibrate current loop function from the Calibration Mode to include the 2 mA outputs as part of the CM4's fault routine. See [Section 5.4](#) for information on the calibrate current loop function.

Instructions

1. Press PROGRAM to exit Monitor Mode.
2. From the 3-SET-UP MENU, choose the subfunction 3-OUTPUT OPTIONS, then 5-2 mA FAULT OPER.

3 - SET-UP MODE

3 - OUTPUT OPTION

5 - 2 mA FAULT OPER

3. Press ENTER.
4. Press CURSOR ARROW RIGHT to toggle between enabling and disabling the 2 mA fault signal.

The display reads:

2 mA FAULT=ENABLED

5. Press ENTER to acknowledge the selection.

7.4.6 Enable/Disable Duty Cycle Option (3.3.6)

Purpose

The Duty Cycle option allows you to select a minimum time period before the next window will advance. With the introduction of XP Chemcassette® gas calibrations, the Duty Cycle period has been changed to be as long as the window time for the selected gas calibration family. The window will not advance regardless of the gas condition. This will slow the Model CM4's response, but reduce tape consumption.

The minimum window time (or Duty Cycle) defaults to zero seconds. It may however be set to a larger number to conserve tape in installations that have some concentration of gas for long periods of time. The tape will not advance until the minimum window time has accumulated, even if the tape is saturated. During periods when the tape is saturated but

prevented from advancing, the CM4 will continue to report the most recent concentration reading. However, it will not report any changes in the concentration during this period, because the tape is saturated.

The Monitor relay (RY6) will energize when monitoring is temporarily suspended due to tape saturation. Note however, any one point that is enabled for Duty Cycle will cause the Monitor relay (RY6) to energize regardless if some points have not been selected (enabled) for Duty Cycle. In the CM4 software, the “monitor relay action during Duty Cycle” bits default to TRUE, but can be set to FALSE with the following procedure.

Instruction

If the Duty Cycle option is installed, you can use Menu Function 3.3.6 (EN/DIS Duty Cycle) to enable or disable the Duty Cycle function for each point. Use Menu Function 3.5.6 (Set Duty Cycle) to program the Duty Cycle time function.

Follow these steps to enable/disable the Duty Cycle for each point:

1. Press PROGRAM to exit Monitor Mode.
2. From the 3–SET-UP MENU, choose the subfunction 3–OUTPUT OPTIONS, then 6–EN/DIS DUTY CYCLE.

3 – SET-UP MODE

3 – OUTPUT OPTION

6 – EN/DIS DUTY CYCLES

NOTE:

Duty Cycle is a factory-enabled option. If not set at the factory, then it is not available to user.

3. The display reads:

SELECT POINT

Use the numeric keys to specify a point.

4. The display will read:

PT 1 ENABLE 1=Y 0=N

Choose 1 or 0 to enable or disable that point for Duty Cycle.

5. Select other points, if desired, or press RESET/ESCAPE key.

7.5 Function 3.4 – Configuration

Purpose

Use the configuration function to:

- Save new instrument configurations
- Restore an existing instrument configuration after changing configuration parameters or a RESET SYSTEM that returned parameters to the factory default

System configuration consists of all configurable parameters defined in the Set-Up Menu.

Instructions

1. Press PROGRAM to exit Monitor Mode.
2. From the 3–SET-UP MENU, choose the subfunction 4–CONFIGURATION.

3 – SET-UP MODE

4 – CONFIGURATION

The display reads:

1=SAVE 2=LOAD CONFIG

3. Press either:
 - 1 to save the current configuration (including all changes)
or
 - 2 to restore the most recently saved configuration.

After selecting 1, the display reads:

CONFIGURATION SAVED

After selecting 2, the display reads:

CONFIG LOADED

The CM4 returns automatically to the Set-Up Menu.

7.6 Function 3.5 – Date & Time

Use the date & time function to set:

- Date format
- Current date and time
- Display time for concentrations displayed in Monitor Mode
- Print time for the TWA
- Time interval the CM4 operates in Idle Mode before issuing a maintenance fault
- Optional duty cycle time

7.6.1 Date Format (3.5.1)

Purpose

Use the date format function to change the format for the month and day that is displayed and printed on all outputs.

Instructions

1. Press PROGRAM to exit Monitor Mode.
2. From the 3–SET-UP MENU, choose the subfunction 5–DATE & TIME, then 1–DATE FORMAT.

3 – SET-UP MODE

5 – DATE & TIME

1 – DATE FORMAT

The default time and the date format is MM/DD/YR.

3. Press CURSOR ARROW RIGHT to toggle between the following formats:

DATE = DD/MM/YR

DATE = MM/DD/YR

4. Press ENTER to acknowledge the selection.

7.6.2 Set Date & Time (3.5.2)

Purpose

Use the set date & time function to set the current date and time. The clock in the CM4 is based on 24-hour time.

Instructions

1. Press PROGRAM to exit Monitor Mode.
2. From the 3–SET-UP MENU, choose the subfunction 5–DATE & TIME, then 2–SET DATE & TIME.

3 – SET-UP MODE

5 – DATE & TIME

2 – SET DATE & TIME

The display reads:

06/21/04 13:36

3. Press CURSOR ARROW LEFT/RIGHT to move forward/backward between date and time.

4. Use the numeric keys to enter the desired date and time.
5. Press ENTER to record the changes.

7.6.3 Set Display Cycle (3.5.3)

Purpose

Use the set display cycle function to set the amount of time the concentration level for each point is displayed while monitoring. Default is four seconds.

Instructions

1. Press PROGRAM to exit Monitor Mode.
2. From the 3–SET-UP MENU, choose the subfunction 5–DATE & TIME, then 3–SET DISPLAY CYCLE.

3 – SET-UP MODE

5 – DATE & TIME

3 – SET DISPLAY CYCLE

The displays reads:

DISPLAY CYCLE 04 SEC

3. Use the numeric keypad to enter the desired display time, between 2 and 10 seconds.
4. Press ENTER to save the display time and return to the set date & time function.

The display shows:

DISPLAY CYCLE IS SET

DATE AND TIME ◀▶

7.6.4 Set TWA Printout Time (3.5.4)

Purpose

Use the set TWA time function to set the time for printing the time weighted average, with a printout occurring every eight hours after the set time. The exact time of TWA printout may be as much as 45 minutes later than the value entered here. This is because the TWA printout occurs only after a tape advance.

The valid range for TWA printout times is 00:00 to 07:59. If a TWA printout time is entered which is outside of this range then 8 or 16 hours will be subtracted from it to make the TWA printout time in the range 00:00 to 07:59.

Instructions

1. Press PROGRAM to exit Monitor Mode.
2. From the 3–SET-UP MENU, choose the subfunction 5–DATE & TIME, then 4–SET TWA TIME.

3 – SET-UP MODE

5 – DATE & TIME

4 – SET TWA TIME

The display reads:

PRINT TWA 00:00

The cursor flashes over the first zero.

3. Use the numeric keys to enter the desired time interval for printing the TWA. For example, to print at 11:59 a.m., press 1, 1, 5, 9.
4. Press ENTER. The display reads:

TWA TIME UPDATED

The CM4 returns automatically to the date and time function.

7.6.5 Set Idle Time (3.5.5)

Purpose

Use the set idle time function to set the amount of time the CM4 remains out of Monitor Mode before causing an instrument fault. This is to prevent the unit from being accidentally left out of Monitor Mode.

Instructions

1. Press PROGRAM to exit Monitor Mode.
2. From the 3–SET-UP MENU, choose the subfunction 5–DATE & TIME, then 5–SET IDLE TIME.

3 – SET-UP MODE

5 – DATE & TIME

5 – SET IDLE TIME

The display reads:

IDLE TIME = 15 MIN

3. Use the numeric keys to enter the desired idle time, between 0 and 45 (0 disables this function).
4. Press ENTER to save the new time and return to the date and time menu.

7.6.6 Set Duty Cycle (optional) (3.5.6)

Purpose

Use the optional set duty cycle to set an interval at which the CM4 samples. The Chemcassette® is not advanced until the duty cycle interval has elapsed, thereby minimizing tape consumption for known high background levels.

Instructions

1. Press PROGRAM to exit Monitor Mode.

2. From the 3–SET-UP MENU, choose the subfunction 5–DATE & TIME, then 6–SET DUTY CYCLE.

3 – SET-UP MODE

5 – DATE & TIME

6 – SET DUTY CYCLE

The display reads:

DUTY CYCLE = 900 SEC

3. Use the numeric keypad to enter the desired time period, in seconds, at which the CM4 samples. 900 seconds (for standard calibrations) and 2700 seconds (for XP calibrations) are the maximums. Enter 000 to disable the duty cycle function.
4. Press ENTER to save the set duty cycle time and return to the date and time function.

7.7 Function 3.6 – Access Setup

Password protection is included for selected menu functions. The keyboard lock password is now used also for the menu password.

One password is used for the Model CM4. It controls access to keyboard lock, protected menu access, and optionally enabled menu access.

The password is optional for the following menu entries:

- | | |
|-----|-------------------|
| 1.2 | MANUAL K-FACTOR |
| 1.3 | CAL CURRENT LOOP |
| 1.4 | TUNE CURRENT LOOP |
| 3 | SET-UP MODE |
| 4.6 | SET FLOW |
| 4.8 | PUMP LIMITS |

A password is required for the access to these menu functions:

- 4.1 RELAY/LED TEST
- 4.2.1 ALM INDICATOR TEST
- 4.2.2 SIMULATD ALM TEST
- 4.2.3 OPTICS ALM TEST
- 4.4 RESET SYSTEM

Optional password checking may be enabled or disabled through menu function 3.6.2 EN/DIS MENU PASSWORD. The default is DISABLED.

7.7.1 Set Key Lock Code

Purpose

Use the access setup function to change the passcode, a five-digit, personal code that locks the keypad from unauthorized access when in the Monitor Mode. The factory default key lock code is 90000.

Instructions to enable (/disable) keypad password protection

1. Press PROGRAM to exit Monitor Mode.
2. From the 3-SET-UP MENU, choose the subfunction 6-ACCESS SETUP, then 1-EN/DIS KBD LOCK.

3 – SET-UP MODE

6 – ACCESS SETUP

1 – EN/DIS KBD LOCK

The display reads:

SET KEYPAD LOCK

Use the cursor keys to toggle between enabled and disabled.

3. Press ENTER at the desired selection. The display will read:

ENTER OLD CODE 9*****

It is not possible to set the key lock code unless the old code is known and entered. Enter the old code and press ENTER. The display reads:

ENTER NEW CODE 9*****

4. Enter the new code by moving the cursor across the five digits, entering a new digit at each position.

NOTE:

The digits are not updated until the last digit is entered.

The display reads:

VERIFY CODE 9*****

5. Enter the new code again, exactly as before.

NOTE:

You must enter the new number again to update the key lock code. If the code is not duplicated, the display reads:

MISMATCH – UNCHANGED

6. Repeat steps 4 and 5 to enter and verify the new code.

If the code is successfully verified, the display reads:

CODE CHANGED

The CM4 returns automatically to the Set-Up Menu after entering the code.

NOTE:

Once the key lock code is enabled, the key lock code can be entered (while in Monitor Mode) and will lock out the keypad until the code is entered again.

See [Section 4.7](#) for information on keypad lock operation.

7.8 Function 3.7 – Maintenance Set-Up

Use the maintenance set-up function to enable/disable:

- Fault counter that indicates low Chemcassette®
- Prompt that indicates the need for internal filter replacement
- Prompt that indicates the need for sample line filter replacement, if so equipped

See [Section 8.6](#) for information about resetting timers.

7.8.1 Chemcassette® Counter (3.7.1)

Purpose

Use the Chemcassette® counter function to enable/disable a fault that occurs when less than 24 hours of Chemcassette® remains, based upon a descending counter. See [Section 9.2](#) for information about replacing the Chemcassette®.

NOTE:

Disabling the counters eliminates faults that would otherwise occur when the Chemcassette® tape supply is low (24 hours remaining) or when the internal and external filters need to be replaced. If any counter is disabled, the reset prompts for that counter will not appear as shown here.

Instructions

1. Press PROGRAM to exit Monitor Mode.
2. From the 3–SET-UP MENU, choose the subfunction 7–MAINTENANCE SET-UP, then 1–CHEMCASS CTR.

3 – SET-UP MODE

7 – MAINT. SET-UP

1 – CHEMCASS CTR

The display shows:

COUNTER ENABLED

3. Press CURSOR ARROW RIGHT to toggle between enabling and disabling the Chemcassette® counter.
4. Press ENTER to save the selection and return to the Maintenance Set-Up menu.

7.8.2 Internal Filter Timer (3.7.2)

Purpose

Use the internal filter timer to:

- Enable/disable a display during Load Chemcassette® (see [Section 8.6](#)) that indicates the number of days remaining before internal filter replacement is required
- Define the number of days, from 30 to 365, before filter replacement is required

See [Section 6.7](#) for information on displaying the system configuration, which shows the amount of days.

Instructions

1. Press PROGRAM to exit Monitor Mode.
2. From the 3–SET-UP MENU, choose the subfunction 7–MAINTENANCE SET-UP, then 2–INT. FILTER TIME.

3 – SET-UP MODE

7 – MAINT. SET-UP

2 – INT. FILTER TIME

The display shows:

INT. FILTER 000 DAYS

The cursor flashes over the first zero. The default is 000, which indicates that the timer is disabled.

3. If you want to:
 - Disable the counter, enter zeros for all three digits
 - Enable the counter, use CURSOR ARROW LEFT/RIGHT to move forward/backward to the desired digit
4. Use the numeric keys to enter a value between 30 and 365 days.
5. Press ENTER to save the selection.

The display returns automatically to the maintenance set-up function.

7.8.3 External Filter Timer (3.7.3)

Use the external filter timer to:

- Enable/disable a display during Load Chemcassette® (see [Section 8.6](#)) that indicates the number of days remaining before the external filters at the end of the sample lines, if so equipped, require replacement
- Define the number of days, from 30 to 365, before filter replacement is required

See [Section 6.7](#) for information on displaying the system configuration, which shows the amount of days.

Instructions

1. Press PROGRAM to exit Monitor Mode.
2. From the 3-SET-UP MENU, choose the subfunction 7-MAINTENANCE SET-UP, then 3-EXT. FILTER TIME.

3 – SET-UP MODE

7 – MAINT. SET-UP

3 – EXT. FILTER TIME

The display shows:

EXT FILTER 000 DAYS

The cursor flashes over the first zero. The default is 000, which indicates that the timer is disabled.

3. If you want to:
 - Disable the counter, enter zeros for all three digits
 - Enable the counter, use CURSOR ARROW LEFT/RIGHT to move forward/backward to the desired digit.
4. Use the numeric keys to enter a value between 30 and 365 days.
5. Press ENTER to save the selection.

The display returns automatically to the maintenance set-up function.

8 Service Menu

8.1 Introduction

The Service Menu provides access to a variety of diagnostic tests and routine service procedures. The Service Menu contains eight functions.

- 4 SERVICE MENU
- 4.1 RELAY/LED TEST
- 4.2 ALARM TEST
- 4.3 DIAGNOSTICS
- 4.4 RESET SYSTEM
- 4.5 LOAD Chemcassette
- 4.6 SET FLOW
- 4.7 MDA SERVICE
- 4.8 PUMP LIMITS

Figure 8-1: Service Mode Menu

The following is an overview of each of the eight functions. The following sections describe each of these functions in detail:

- 4.1 RELAY/LED TEST checks all LED indicators and alarm relays (see [Section 8.2](#))
- 4.2 ALARM TEST checks alarm LEDs and alarm relays (see [Section 8.3](#))
- 4.3 DIAGNOSTICS prints out operational information about the CM4 (see [Section 8.4](#))
- 4.4 RESET SYSTEM deletes all operator-programmed settings and replaces them with the factory default settings (see [Section 8.5](#))
- 4.5 LOAD Chemcassette®/FILTER CHANGE, if selected, will reset the tape counter after loading a new Chemcassette® (see [Section 8.6](#))

- 4.6 SET FLOW balances the sample flowrates at each point from all CM4 sample lines through the system (see [Section 8.7](#))
- 4.7 MDA SERVICE for use by MDA service technicians only (see [Section 8.8](#))
- 4.8 PUMP LIMITS (see [Section 8.9](#))

8.2 Function 4.1 – Relay/LED Test

Purpose

Use the Relay/LED Test to test **all** LED indicators and **all** relays except the Watch Dog relay.

NOTE:

The relay test simulates an actual alarm condition and the CM4 activates the appropriate connected relays (including point alarms and general alarms). Notify appropriate personnel that you plan to conduct a test.

Instructions

1. Press PROGRAM to exit Monitor Mode.
2. From the 4–SERVICE MENU, choose the subfunction 1–RELAY/LED TEST.

4 – SERVICE MODE

1 – RELAY/LED TEST

Press 1 again to turn on all fault and alarm relays and all LEDs

or

Press ENTER to choose either LEDs or relays. The display reads:

1=LEDs ONLY 2=RELAYS

3. Press 1 to light all LEDs.

Press 2 to activate all output relays. The display reads:

CONFIRM TEST

followed by:

1=LEDs ONLY 2=RELAYS

4. Press 2 to confirm the selection and activate all relays and light all LEDs. The display reads:

PRESS RESET TO END

Press RESET to exit to the Service Menu without activating outputs.

8.3 Alarm Tests

8.3.1 Function 4.2.1-Alarm Indicator Test

Purpose

Use the alarm indicator test function to:

- Test alarm LEDs and relays for individual Points
- Select Level 1 and/or Level 2 Alarms for each point

NOTE:

The alarm test simulates an actual alarm condition and the CM4 activates the appropriate connected relays (including point alarms and general alarms). Notify appropriate personnel that you plan to conduct a test.

Instructions

1. Press PROGRAM to exit Monitor Mode.
2. From the 4–SERVICE MENU, choose the subfunction 2–ALARM TESTS.

4 – SERVICE MODE

2 – ALARM TESTS

1 – ALM INDICATOR TEST

ENTER CODE 9XXXX

SIM ON NET 1=Y 0=N

Pressing 0 causes the indication of simulated alarms to appear only on the relays and front panel LEDs. Pressing 1 causes alarm indication additionally to appear on the digital network. This includes the LONWORKS®, Control Net, Profibus and CM4 Serial Communication protocol.

The display shows:

SELECT POINT

3. Press 1, 2, 3 or 4 to select the point for testing. The display reads:

PT 1 LEVEL?

4. Use the numeric keys to press 1 or 2 to indicate Level 1 or Level 2 Alarm. The display reads:

CONFIRM TEST

5. Repeat Step 4 to confirm the selection. The appropriate alarm relays activate.

If desired, continue to select points and alarm levels for testing by repeating steps 2 through 4.

Press RESET to exit the alarm test function, reset all alarm relays, and return to the Service Menu.

8.3.2 Function 4.2.2-Simulated Alarm Test

Purpose

Use this function to simulate a gas concentration while the instrument is in the Monitor Mode. In the Alarm Test Mode, the Model CM4 will permit the insertion of the Optics Test Card into the optics block to simulate a stain.

The Alarm Test Mode can be enabled or disabled using menu function 4.2.2 SIMULATD ALM TEST. When the Alarm Test Mode is activated, the Model CM4 prints “ALARM SIMULATION MODE STARTING.”

CM4 Four-Point Continuous Monitor

When the simulation mode ends (by user or time-out), the printer will print “ALARM SIMULATION MODE ENDING.”

The Optics Test card can be used to simulate a gas stain in this mode. The simulated gas stain will drive all the enabled CM4 features as if an actual gas stain was detected on the current Chemcassette® window.

In this mode, the Model CM4 will not recognize or report:

- Gate Open Fault
- Low Flow Fault
- High Background Fault
- End of Chemcassette® Fault

While the mode is active, the fifth line of the front panel display will show:

ALM SIM MODE=XXX SEC

where “xxx” is the number of seconds before the mode resets.

Instructions

Follow these steps to simulate an alarm:

1. Exit the Monitor Mode
2. Enable the Alarm Test Mode in menu entry 4.2.2. Press ENTER.
3. Open the gate and place the Optics Test Card (Stain 1) in the optics block. Close the gate.
4. Press MONITOR.

Wait until the fifth line on the display shows:

ALM SIM MODE = xxx SEC

5. Open the gate and place the Optics Test Card (Stain 2) in the optics block. Close the gate.

- The Model CM4 will produce full scale alarms on all four points initially. Wait for the concentration to decay. Typically, this takes about two minutes.

6. Press RESET to reset any alarms.
7. Reinstall the proper Chemcassette® when testing is complete.

The simulated alarm test mode remains active until:

- Power is cycled
- 15 minutes elapse in this mode
- The mode is canceled via menu selection 4.2.2

The Alarm Simulation Mode is documented on printouts and in the Model CM4’s Alarm History. The serial printer output shows the start and end of the alarm simulation. Also, the abbreviation (SIM) is printed on alarm reports to indicate the Model CM4 was in simulation mode when the alarm occurred. [Figure 8-2](#) shows a sample printout.

NOTE:

Hydrogen Sulfide (H₂S) creates an unusually dark stain on the Hydrogen Sulfide Chemcassette®, P/N 874304. Because of this, the algorithm will sometimes not report an alarm level concentration when alarm simulation is attempted with the standard optics test card. Work-arounds include temporarily setting the alarm levels lower. For more information, contact Honeywell Analytics Service.

This condition affects the Hydrogen Sulfide Chemcassette® P/N 874304 only. Hydrogen Sulfide detection with the Hydrides Chemcassette®, P/N 874300 is not affected.

8.3.3 Function 4.2.3-Optics Alarm Test

Purpose

Use this function to verify the optics subsystem using the stain card and simulate a concentration on points that pass. On selected points that read correctly, the current loop output will produce 12 mA, the Alarm LEDs flash and the alarm 1 and alarm 2 relays activate. When a selected point passes, the general alarm 1 and alarm 2 relays activate. The following messages are printed:

OPTICS ALM TEST STARTING

OPTICS ALARM TEST ENDING

NOTE:

Before starting the test, the software requests the menu password and asks you to select the point on which the outputs are to be produced.

Instructions

The criteria for testing the optics block is the same as used for menu function 1.1 (Optics Verify). If all four points pass, the date of a successful measurement is recorded for the configuration printout.

No entry is made in the alarm history. Also, the serial communication protocol will not provide any indication of this test.

[Table 8-1](#) is a sample dialogue between the Model CM4 and a typical user.

06/23/05	09:10	CM4-851-0006	ALARM SIMULATION MODE STARTING
06/23/05	09:11	CM4-851-0006	STARTING TWA
06/23/05	09:11	> 75.0 PPM NH3-II	PT4-CM4-851-0006 LEVEL 2 ALARM (SIM)
06/23/05	09:11	CM4-851-0006	MONITORING ENDED
06/23/05	09:11	CM4-851-0006	ALARM SIMULATION MODE ENDING

Figure 8-2: Sample Alarm History Printout

Command	Action
SELECT PROGRAM ◀▶	The user types 4
SELECT MENU ◀▶	The user types 2
ALARM TESTS MENU ◀▶	The user types 3
ENTER CODE 9XXXX	The user types the password
SELECT POINT 0 - ALL	The user enters 3 for point 3 output only
INSERT STAIN 1 - PRESS ▶	The user inserts the optics test card and presses arrow ▶
INSERT STAIN 2 - PRESS ▶	The user flips the card and presses arrow ▶
PASSED PT (3)	Four relays activate (RY5 RY13 RY2 and RY4) for a level 2 alarm on point 3. The four current outputs produce 4, 4, 12 and 4 mA respectively. The point 3 alarm LED flashes red and the following string is printed: OPTICS ALARM TEST STARTING PASSED POINTS {3}
ALARM TESTS MENU ◀▶	The user types 3 and the password to repeat the function
SELECT POINT 0 - ALL	The user enters 0 for output on all points
INSERT STAIN 1 - PRESS ▶	The user inserts the stain card as directed twice
PASSED PT (1234)	The output listed above activate an the following string is printed: OPTICS ALARM TEST STARTING, PASSED POINTS {1234}. The user types <RESET> to end the test.
ALARM TESTS MENU ◀▶	The user types 3 and the password to repeat the function
SELECT POINT 0 - ALL	The user enters 1 for output on point 1 only
INSERT STAIN 1 - PRESS ▶	The user inserts the stain card incorrectly or the optics hardware for point 1 is out of tolerance
PASSED PT (NONE)	No relay or other output activates. The following is printed: OPTICS ALARM TEST STARTING, PASSED POINTS {NONE}

Table 8-1: Sample Dialog Between CM4 and User

8.4 Function 4.3 – Diagnostics

Purpose

Use the diagnostics function to print and display a report that shows the software revision number and checksums.

Also use this function to perform a diagnostic check on all circuit boards in the system, including a check of:

- Valves for shorts and opens
- Power supply levels
- Flow transducer operation
- Optics drive values

Instructions

1. Press PROGRAM to exit Monitor Mode.
2. From the 4–SERVICE MENU, Choose the subfunction 3–DIAGNOSTICS.

4 – SERVICE MODE

3 – DIAGNOSTICS

The display reads:

PRINT REPORT 1=Y 0=N

3. Press either:
 - 1 to print and display the report
or
 - 0 to display the report.
4. Press CURSOR ARROW LEFT/RIGHT to move the cursor forward/backward through the data. The CM4 shows a sequence of displays:

Software version and flash memory kernel

SW 1: P3.03 K1.1

Gas calibration table version

SW 2: G1.31

Firmware checksums

SW 3: P=6723 P=5495

Real-time raw optics counts

2317 1844 1439 1168

Tape windows remaining

CC WINDOWS = 0000

Real-time position of tape advance sensor and count of extra windows pulled

Tape POS000000 EW 0

Power supply voltages

PS 12.3 5.0 0.2 24.2

Optics DAC drive values

DRV 083 074 103 094

Q calibration factors

1005 0905 0953 0875

Flow transducer offsets

FO 005 055 059 070

Flow transducer coefficients

FF 100 100 100 100

Neuron ID of LONWORKS interface (if fitted)

NEURON NOT DETECTED

or

LON ID= 123456789012

Pump limit settings

LIMITS HI=500 LO=350

Barometric pressure, optics temperature, internal temperature

AP=29.07 27.4 24.5

Timestamp of erasure of fault and alarm histories

HIST 11/11/99 12:32

8.5 Function 4.4 – Reset System

Purpose

Use the reset system function to:

- Delete all operator-programmed settings and replace them with the factory default setting
- Clear the system of a software error



All user-programmed settings will be set to default.

Instructions

1. Press PROGRAM to exit Monitor Mode.
2. From the 4–SERVICE MENU, choose the subfunction 4–RESET SYSTEM.

4 – SERVICE MODE

4 – RESET SYSTEM

The display shows:

RESET SYSTEM 1=Y 0=N

3. Press either:
 - 1 to reset all system parameters to the factory defaults and to reboot the CM4
 - or
 - 0 to keep the current system parameters

Use the configuration function from the Set-Up menu to retrieve a previously saved configuration (see [Section 7.5](#)).

8.6 Function 4.5 – Load Chemcassette®/Filter Change Purpose

Use the load Chemcassette® function to reset the tape counter when loading a new Chemcassette®.

To ensure system integrity, a new Chemcassette® should be replaced before the old Chemcassette® runs out of tape.

The CM4 automatically keeps track of Chemcassette® tape usage, and reports a “Low Tape” fault when the Chemcassette® is nearing the end of the reel. For this feature to work, reset the tape counter when installing a fresh Chemcassette®. Do not reset the tape counter if rethreading or realigning a previously installed Chemcassette®.

The CM4 can detect common human errors during the tape loading process to increase the integrity of monitoring. Each Chemcassette® includes a unique 12-digit Chemcassette® Identification (CID) number that identifies the manufacture date, the Chemcassette® type and the serial number. This number is entered into the CM4 during tape loading.

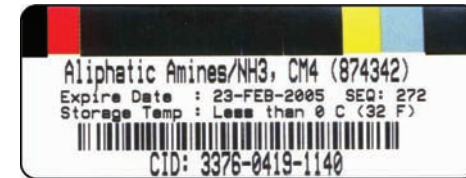

Figure 8-3: Chemcassette® Label with CID

NOTE:

Disabling the counters eliminates faults that would otherwise occur when the Chemcassette® supply is low (24 hrs remaining) or when the internal and external filters need to be replaced. See [Section 7.8.1](#) to enable/disable the Chemcassette® and [Section 7.8.2](#) to enable/disable the filter counters. If any counter is disabled, the reset prompts for that counter will not appear as shown in [Section 7.8.1](#).

WARNING

Install the correct Chemcassette®. (See [Appendix C](#) for part number information.) Make sure the label on the Chemcassette® matches the label on the analyzer. Using an incorrect Chemcassette® defeats the CM4's ability to warn of dangerous gas concentrations.

Instructions

1. Press PROGRAM to exit Monitor Mode.
2. From the 4–SERVICE MENU, Choose the subfunction 5–LOAD Chemcassette®.

4 – SERVICE MODE

5 – LOAD Chemcassette

3. Press ENTER. If the Chemcassette® counter is enabled, the display briefly reads:

CC XXX DAYS LEFT

The display then reads:

RESET COUNTER 1=Y

4. Press either:
 - 1 to re-initialize the counter so that the display shows a fault when less than 24 hours of Chemcassette® remains
 - or
 - 0 to continue without resetting timer

If the internal filter timer is active (see [Section 7.8.2](#)).

The screen displays:

XX DAYS REMAINING

then displays:

INT. FILTER RESET 1=Y

5. Press either:
 - 1 to reset the timer after servicing the filters (see [Section 9.3](#))
 - or
 - 0 to continue without resetting timer

If the external filter time is active (see [Section 7.8.3](#)). The screen displays:

XX DAYS REMAINING

then displays:

EXT. FILTER RESET 1 = Y

6. Press either:
 - 1 to reset the timer after servicing the filters (see [Section 9.3](#))
 - or
 - 0 to continue without resetting timer

The display reads:

USES Chemcassette

The display will then show the Chemcassette® type for your CM4 calibration.

HYDRIDES

Enter the CID number found on the label of the replacement Chemcassette®:

CID? XXXX-XXXX-XXXX

CM4 Four-Point Continuous Monitor

If there is a problem with the CID number or the Chemcassette®, the display will show one of the following messages:

Message	Cause	Recovery	Imminent Fault	
			Inst	Maint
UNKNOWN Chemcassette®	User pressed ESCAPE or ENTER instead of entering a number	Retype CID number	Unchanged	
INVALID NUMBER	CID mistyped	Retype CID number	Unchanged	
IMPROPER Chemcassette®	Wrong tape for gas family	Use different Chemcassette®	Y	N
Chemcassette® EXPIRED	Time since mfg too long	Use newer Chemcassette®	N	Y
CC PAST EXPIRY	Time since mfg twice too long	Use newer Chemcassette®	Y	N
Chemcassette® STALE	This CC previously installed and out of bag too long (See Table 8-2)	Use newer Chemcassette®	N	Y
CC VERY STALE	This CC previously installed and out of bag twice too long (See Table 8-2)	Use newer Chemcassette®	Y	N
CC EXP FLT IN XX DAY	This CC will be expired or stale before it is consumed, in XX days.	Replace Chemcassette® before XX days elapse	None Imminent	

When the correct CID has been entered, press the ENTER key. The display will read:

OPEN GATE/REPLACE CC

After opening the gate, the display reads:

CHANGE CC/CLOSE GATE

After installing the carrier with a new Chemcassette® (see [Section 9.2.4](#) for information on loading Chemcassette®) and closing the Gate Load Lever, the following is displayed:

ADVANCE? 1=Y

7. Press either:

- 1 to advance the Chemcassette® five windows to verify proper threading/loading

or

- 0 to exit the LOAD Chemcassette® function without advancing the tape.

The CM4 returns automatically to the Service Menu.

8. After replacing Chemcassette®, always verify the optics (see [Section 5.2](#)) and set the sample flow (see [Section 8.7](#)).

Description	Part Number	Lifetime in Bag (# days)	Lifetime out of bag (# days)
Hydrides	874300	183	35
Mineral Acids	874337	183	35
Ammonia	874402	183	16
Phosgene	874307	183	35
Hydrogen Sulfide	874304	183	35
Hydrogen Cyanide	847510	183	16
Hydrazine	874347	183	35
Aliphatic Amines/Ammonia	874342	183	35
Chlorine/Oxidizers	874007	183	16
Fluorine/Oxidizers	1874-9306	183	35
XPC Hydrides	1874-9300	365	100
XPC Mineral Acids	1874-9310	365	100
XPC Ammonia	1874-9309	365	100
XPC Chlorine	1874-9308	365	100
XPC Phosgene	1874-9307	365	100

Table 8-2: Chemcassette® Lifetimes

8.7 Function 4.6 – Set Flow

Use the set flow function to select flow balance for each point.

Instructions

1. Press PROGRAM to exit Monitor Mode.
2. From the 4–SERVICE MENU, choose the subfunction 6–SET FLOW.

4 – SERVICE MODE

6 – SET FLOW

The display reads:

ADJUST FLOWS TO

180 180 180 180

The initial flows are displayed

180 168↑ 220↓ 292↓

In this example, notice that Point 1 is within the correct flow range, but Points 2, 3 and 4 are out of range, as indicated by the arrows. Use the needle valves on the front panel (see [Figure 8-4](#)) to adjust each point to +/- 5% of setpoints.

When Point 2 is corrected, the display shows:

186 178 220↓ 292↓

When Point 3 is corrected, the display shows:

186 178 171 292↓

When Point 4 is corrected, the display shows:

186 178 169 182

In this example, notice that Point 3 has drifted out of range. The instrument indicates the condition by displaying the following:

PT 3 OUT OF RANGE

NOTE:

The previous display occurs only when you are exiting SET FLOW.

ADJUST=1 EXIT=2

Select 1 to correct the out of range condition.

The display shows:

186 178 180 182

All four flows are now correct. Press RESET or ENTER to return to the Service Menu.

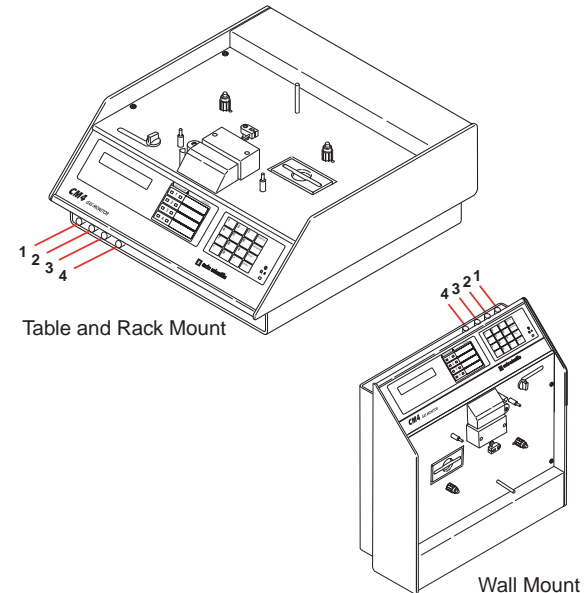

Figure 8-4: Point Flow Adjustments

Legend

1	Pt 1 Flow Adjustment	3	Pt 3 Flow Adjustment
2	Pt 2 Flow Adjustment	4	Pt 4 Flow Adjustment

8.8 Function 4.7 – MDA Service

Purpose

MDA service engineers use this function to perform diagnostics and service. This function requires a passcode.

8.9 Function 4.8 – Pump Limits

This mode allows you to program the limits that trigger the pump failure fault. It also allows you to disable the limits, if desired.

8.9.1 Operation

The Pump Failure Fault is used to differentiate a supply vacuum fault from a point-specific Flow Failure. The pump fault levels settings should be made during the instrument installation to accommodate the application. Setting the limit to “000” will disable the fault operation.

“Normal Reading”

The vacuum measurement in operation is used to determine clogged filters, kinked inlet/exhaust tubing, or pump failure. With the pump running a “normal reading” with no tubing attached to the CM4 monitor, the reading should be 375-475 counts (13.8 to 17.5 inches Hg, or 350-495 torr), depending on current barometric pressure, voltage, frequency, and other tolerances of the system. If you encounter readings above or below these counts, a secondary check of point flow rate is recommended. Point flow should be 2.8 Liters per minute per point minimum with up to 300 feet of tubing connected.

Ambient Pressure Reading

The typical reading near sea level is approximately 800 counts for an atmospheric reading of 28.4 to 30.5 inches of mercury (inches Hg) (721-775 torr). The reading will vary approximately 26 counts per inch (1 count per torr) change of barometric pressure. This variance is included in selecting fault thresholds.

Altitude should also be considered. At an altitude of 6000 feet (1800 m), and the pressure of 24 inches Hg would produce a reading of approximately 651 counts. The capacity of the pump is reduced due to the lower density air.

The transducer will display the count value of the absolute pressure on the vacuum side. When the pump is not running, the ambient pressure is represented. This reading can vary due to transducer tolerance, atmospheric pressure, altitude, or differential pressures developed between sample and exhaust connections of the system.

NOTE:

Always use 3/16-inch (4.7 mm) I.D. 1/4-inch (6.35 mm) O.D. FEP Teflon tubing for sample lines, 300 ft. (90 m) maximum per point. Use 3/16-inch (4.7 mm) I.D. 1/4-inch (6.35 mm) O.D. tubing for exhaust, 50 ft. (15 m) maximum.

8.9.2 Set-up

Instructions

1. Access Service Mode 4.8 in the SERVICE (4–SERVICE) menu. The display will show:

PRESSURE CTS= 0800

The decimal value of the vacuum transducer is displayed and updated every 1 second. This value is in raw electronic counts, and does not represent flow rate of cc/min. This display alternates with the display shown below until a 1, 2, 3, or ESCAPE is selected.

1 = PUMP 2 = LIMIT 3 = LIT

Selecting ESCAPE exits the mode and returns the software to the Service menu. Selecting 1 toggles the pump On or Off. Selecting 2 switches off the pump and accesses the pump limits settings. Selecting 3 is for Sample Line Integrity Option, (see [Section 10.3](#)).

2. Select 1 to toggle the pump On. A new pressure counts value is displayed. This value is the “normal reading.” You will use this value as a base to set the High and Low Limits.
3. Select 2 to set the High and Low limits. The display will show:

LIMITS HI = 500 LO = 400

The cursor flashes under the first number of the high limit. Using the arrow keys, moves the cursor location left or right. Decimal values 0-9 can also be entered.

4. Set the High Limit value. The recommended default value is 52 +/-12 counts above the “normal reading,” allowing the instrument as installed to exhaust the total flow up to a head pressure of +1 PSIG (52 torr). Vacuum levels that are above the set point may indicate high exhaust pressure, blocked exhaust, low capacity pump, or low supply vacuum. The total flow is reduced, affecting transport times and flow rate through the Chemcassette®. This is due to low differential pressures across the orifice of each point.
5. Set the Low Limit value. The default value recommended is 52 +/-12 counts below the “normal reading,” allowing the instrument to indicate a 25% loss of total flow. Vacuum levels below the limit indicates too much vacuum is detected. Possible causes for this condition are blocked filters at the end of a sample line, internal blocking of the orifices, or a blocked sample line. The vacuum level is produced by pump capacity and the limiting orifice used in each point. Adding four 300-foot sample lines increases the total vacuum level, changing the count value approximately -15 counts or 1/2 inch HG (12 torr).

NOTE:

Setting the limits to 0 will disable the fault being issued.

Once the high and low limits have been selected, press ENTER to store the values. The message “Pump Limits Updated” is printed along with the Time/Date/Serial Number. Pressing ESCAPE will exit the routine, returning the values to pre-programmed levels and not printing any message.

The pump limits are also incorporated into the Service Mode Diagnostics 4.3 printout. The pump limits are also listed on the system configuration printout (2.6 Print Config).

NOTE:

If at any time the system is reset to factory defaults (Function 4.4—RESET SYSTEM), this procedure will need to be redone since the low and high limit values will be reset to factory default values.

8.10 Function 4.9 – Reboot

A reboot function has been added to allow rebooting without cycling Model CM4 power. Figure 8-5 shows the prompts displayed.

Display	Function
9 - REBOOT	Reboot
ENTER CODE 9XXXX	Appears only if menu password is enabled via Section 3.6.2
SAVE CONFIG 1=Y 0=NO	Offer to backup configuration
CONF SAVED INTERNALLY	Confirms that a backup was performed. Also a line will be printed: CONFIGURATION SAVED INTERNALLY
RESTARTING	
CM4	Reboot display

Figure 8-5: Reboot Function Prompts

9 Maintenance

9.1 Introduction

The Maintenance Section includes:

- Chemcassette® Maintenance covers the Chemcassette®, Chemcassette® carrier, optics verification, and flowrate check (**Section 9.2**)
- Filter maintenance covers the replacement of CM4 filters (**Section 9.3**)
- Fuse replacement (**Section 9.4**)
- Cleaning Chemcassette® optics (**Section 9.5**)
- Installing Microtube assemblies (**Section 9.6**)

NOTE:

Prior to performing any maintenance procedure, leave Monitor Mode. (See **Section 4.5.1**.)



For system integrity, always perform a leak test after any maintenance procedure. See **Section B.2 for leak check procedure.**

9.2 Chemcassette® Maintenance

This section describes maintenance and handling procedures for the Chemcassette® and the Chemcassette® carrier.

Perform the following functions when replacing a Chemcassette® tape:

- Remove carrier
- Verify optics
- Load new Chemcassette® in carrier
- Install Chemcassette®
- Check flowrates

9.2.1 Remove Carrier

To remove the Chemcassette® carrier from the CM4:

1. Press PROGRAM to exit Monitor Mode.
2. From the 4–SERVICE MENU, Choose the subfunction 5–LOAD Chemcassette®.

4 – SERVICE MODE

5 – LOAD Chemcassette

If Chemcassette® counter is disabled, proceed to step 6. If Chemcassette® counter is enabled, the screen displays:

RESET COUNTER 1=Y

3. Press either:
 - 1 to re-initialize the counter so that the display shows a fault when less than 24 hours of Chemcassette® remains
 - or
 - 0 to continue without resetting counter

If the internal filter timer is active (see **Section 7.8.2**), the screen displays:

INT FILTER RESET 1=Y

4. Press either:
 - 1 to reset the timer after servicing the filters (see **Section 9.3**)
 - or
 - 0 to continue without resetting timer

If the external filter timer is active (see **Section 7.8.3**), the screen displays:

EXT FILTER RESET 1 = Y

5. Press either:

- 1 to reset the timer after servicing the filters (see [Section 9.3](#))
or
- 0 to continue without resetting timer

The display reads:

USES Chemcassette

The display will then show the Chemcassette® type for your CM4 calibration.

HYDRIDES

Enter the CID number found on the label of the replacement Chemcassette®:

CID? XXXX-XXXX-XXXX

If there is a problem with the CID number or the Chemcassette®, the display will show one of the following messages:

Message	Cause	Recovery	Imminent Fault	
			Inst	Maint
UNKNOWN Chemcassette	User pressed ESCAPE or ENTER instead of entering a number	Retype CID number	Unchanged	
INVALID NUMBER	CID mistyped	Retype CID number	Unchanged	
IMPROPER Chemcassette	Wrong tape for gas family	Use different Chemcassette®	Y	N
Chemcassette EXPIRED	Time since manufacture too long	Use newer Chemcassette®	N	Y
CC PAST EXPIRY	Time since manufacture twice too long	Use newer Chemcassette®	Y	N
Chemcassette STALE	This CC previously installed and out of bag too long (See Table 8-2)	Use newer Chemcassette®	N	Y
CC VERY STALE	This CC previously installed and out of bag twice too long (See Table 8-2)	Use newer Chemcassette®	Y	N
CC EXP FLT IN XX DAY	This CC will be expired or stale before it is consumed, in XX days.	Replace Chemcassette® before XX days elapse	None Imminent	

Description	Part Number	Lifetime in Bag	Lifetime out of bag
Hydrides	874300	183	35
Mineral Acids	874337	183	35
Ammonia	874402	183	16
Phosgene	874307	183	35
Hydrogen Sulfide	874304	183	35
Hydrogen Cyanide	847510	183	16
Hydrazine	874347	183	35
Aliphatic Amines/Ammonia	874342	183	35
Chlorine/Oxidizers	874007	183	16
Fluorine/Oxidizers	1874-9306	183	35
XPC Hydrides	1874-9300	365	100
XPC Mineral Acids	1874-9310	365	100
XPC Ammonia	1874-9309	365	100
XPC Chlorine	1874-9308	365	100
XPC Phosgene	1874-9307	365	100

Table 9-1: Chemcassette® Lifetimes

When the correct CID has been entered, press the ENTER key. The display will read:

OPEN GATE/REPLACE CC

6. Shift the tape load lever to open the optics block. The display reads:

CHANGE CC/CLOSE GATE

7. On older model CM4's, release carrier retaining tab by pressing towards rear of unit.
8. Remove the carrier by placing your hands under it, palms up, and firmly lifting straight up. Apply sufficient upward force to free tape guides from posts. See [Figure 9-1](#).

NOTE:

To avoid carrier torque and damage, do not tilt the carrier. Contact Honeywell Analytics if you are unable to remove the carrier.

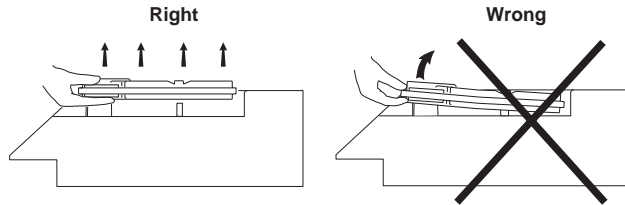

Figure 9-1: Removing the Carrier

9.2.2 Verify Optics

Each time you replace a Chemcassette[®] tape, verify that the CM4 optics system is operating properly using the optics verify function and the optics verification card supplied with your instrument. The CM4 compares the nominal span values stored in the instrument's memory to the values produced by the optics verification card. This procedure verifies that the optics system correctly quantifies gas levels during normal operation.

Instructions

1. Press PROGRAM to exit Monitor Mode.
2. From the 1-CALIBRATION MODE, choose the subfunction 1-OPTICS VERIFY.

1 – CALIBRATION MODE

1 – OPTICS VERIFY

3. Press ENTER.
The display reads:

INSERT STAIN 1 PRESS ▶

4. Open the tape load lever and carefully remove carrier (See **Figure 9-1**).

5. Insert the verification card into the detector head with Stain 1 facing the front of the CM4. Make sure that Stain 1 is fully inserted into the detector head.
6. Carefully close the tape load lever.
7. Press CURSOR ARROW RIGHT on the numeric keypad. The readings for Stain 1 are stored. The display reads:

INSERT STAIN 2 PRESS ▶

8. Open the tape load lever.
9. Remove the verification card.
10. Turn the card and fully insert Stain 2.
11. Carefully close the tape load lever.
12. Press CURSOR ARROW RIGHT.

The display shows one of two messages:

VERIFY SUCCESSFUL

or

F24 OPTICS FAIL 1, 2, 3, 4

13. Open the tape load lever and remove the verification card.

NOTE:

If the optics verification is not successful, repeat the procedure. Contact Honeywell Analytics if the instrument prints and displays the error message after a second optics verification attempt.

14. Reinstall the carrier and close the tape load lever.

Press any key to return to the Calibration main menu.

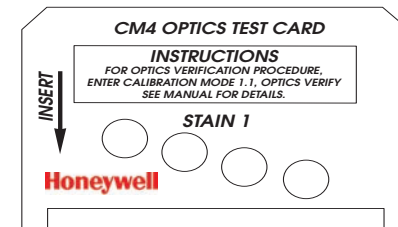

Figure 9-2: Optics Verification Card

9.2.3 Loading the Carrier

To load the Chemcassette® carrier:

1. Open the carrier.
2. Remove the supply reel and discard any remaining Chemcassette® tape. Remove and discard the entire take-up reel.
3. Using your thumb, press the center of the supply reel until the top half separates from the bottom half.
4. Move the bottom (slotted side) of the reel to the take-up position.
5. Place the new supply reel into position and thread the Chemcassette® tape through the slot in the carrier and into the slot on the take-up reel.
6. Turn the take-up reel 3 to 4 times to advance the Chemcassette® tape (2) and take up slack.
7. Reinstall the top half of the take-up reel until a click is heard.
8. Close the carrier.

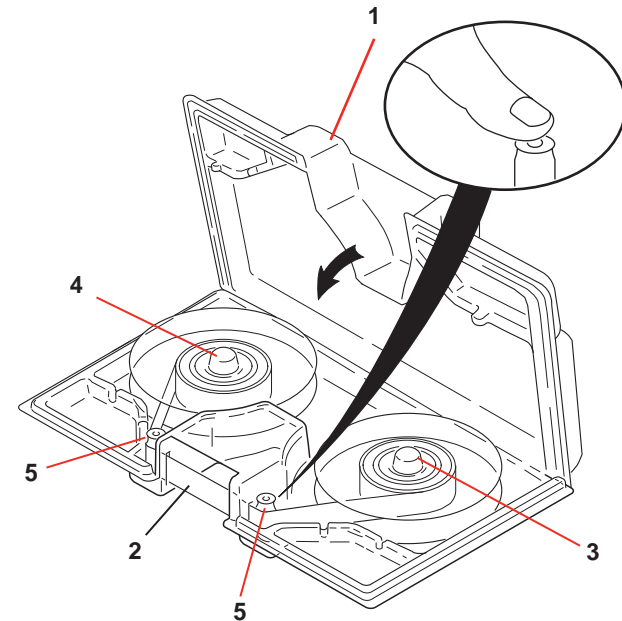

Figure 9-3: Loading the Carrier

Legend

1	Carrier	4	Take-up reel
2	Chemcassette® Tape	5	Tape guide
3	Supply reel		

9.2.4 Installing the Chemcassette®

With the fresh Chemcassette® inside, install the carrier as follows:

1. Open the tape load lever.
2. Install the carrier onto the spool hubs. Make sure the Chemcassette® tape is between the nosepiece and optics block. Also ensure the tape is seated between the capstan and idler roller.
3. If necessary, turn the reel hubs to engage the shafts.
4. Snap the tape guides onto the post by pressing from the top of carrier.

CAUTION

For proper operation, make sure both reel hubs are fully engaged.
The carrier should be resting flat without any wobble.

NOTE:

- If initial power up, go to [Section 4](#). If not, continue with Step 5.
5. Close the tape load lever. The solenoid valve automatically turns on sample flow.

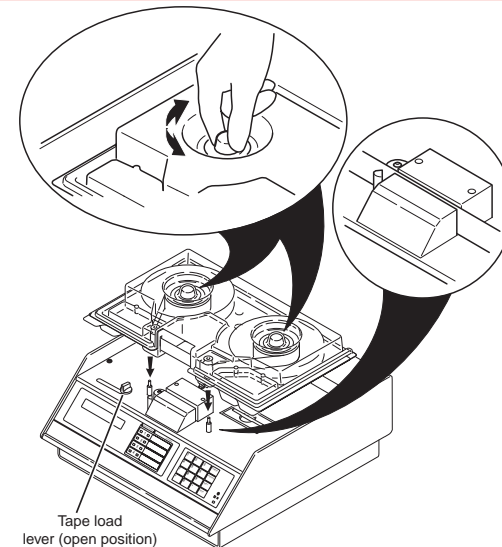

Figure 9-4: Installing the Carrier

9.2.5 Checking Flowrates

Each time you replace a Chemcassette[®] tape, check flowrates while in the set flow function by comparing the flow readings with the nominal rates as shown in the set flow function.

To check the flowrates:

1. If necessary, press PROGRAM to exit Monitor Mode.
2. From the 4–SERVICE MENU, choose the subfunction 6–SET FLOW.

4 – SERVICE MODE

6 – SET FLOW

The display reads:

ADJUST FLOWS TO

180 180 180 180

The initial flows are displayed:

186 168↑ 220↓ 292↓

In this example, notice that Point 1 is within the correct flow range, but Points 2,3 and 4 are out of range, as indicated by the arrows. Use the needle valves on the front panel (see **Figure 9-5**) to adjust each point to ± 5% of setpoints.

When Point 2 is corrected, the display shows:

186 178 220↓ 292↓

When Point 3 is corrected, the display shows:

186 178 171 292↓

When Point 4 is corrected, the display shows:

186 178 169↑ 182

In this example, notice that Point 3 has drifted out of range. The instrument indicates the condition by displaying the following:

PT 3 OUT OF RANGE

NOTE:

The previous display occurs only when you are exiting SET FLOW.

ADJUST=1 EXIT=2

Select 1 to correct the out of range condition.

The display shows:

186 178 180 182

All four flows are now correct. Press RESET or ENTER to return to the Service Menu.

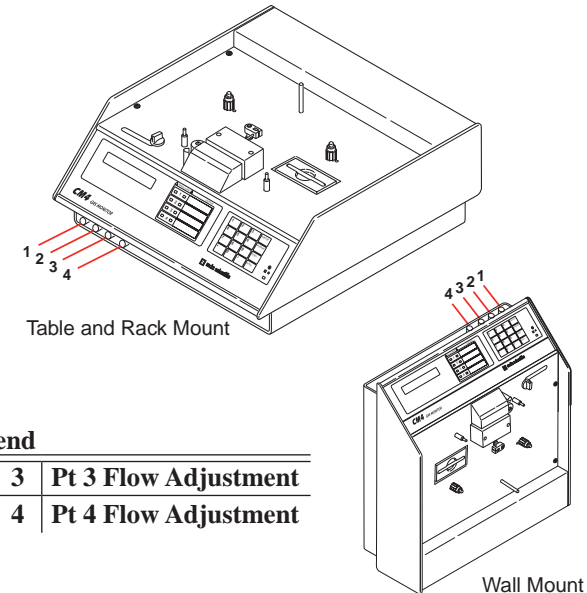

Legend

1	Pt 1 Flow Adjustment	3	Pt 3 Flow Adjustment
2	Pt 2 Flow Adjustment	4	Pt 4 Flow Adjustment

Figure 9-5: Point Flow Adjustments

9.3 Filter Maintenance

The CM4 utilizes filters to protect the unit from dust particles and potentially damaging gases. **Table 9-2** provides maintenance information about filters. **Figure 9-6** shows the relative positions of the various filters. See [Section 3.7](#) for information on external sample line filters.

Name of Filter	Location	Part Number	Replacement Frequency	Notes
Acid Scrubber Filter	Under Chemcassette® carrier See Figure 9-6	710235	6 Months	Replace the filter if the filter media (all or any) part turns blue or sample flowrate cannot be achieved
Particulate Filters	Inside analyzer under Chemcassette® carrier See Figure 9-6	780248	3 to 6 Months	
Charcoal Freon Filters (CM4-P only)	Inside analyzer under Chemcassette® carrier See Figure 9-6	1874-0139	1 Month	
External Sample Line Particulate Filter	End of sample line (if installed)	Gas specific - See Section 3.7 and Appendix A		
Teflon Filter Housing Assembly	End of sample line (if installed)	1830-0055 (filter ass'y)	1 Month	Use filter membrane P/N 0235-1072 (100 per pack) or replacement in filter housing

Table 9-2: Filter Replacement Schedule

CM4 Four-Point Continuous Monitor

9.3.1 CM4 Internal Filter Replacement Procedure

See *Figure 9-6*

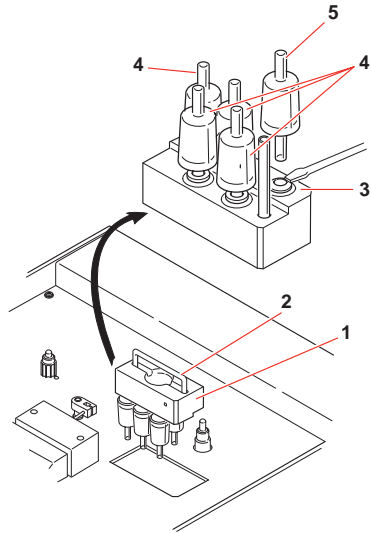

Figure 9-6: Filter Maintenance

Legend

1	Filter block	4	Particulate Filters
2	Filter block handle	5	Acid scrubbing filter
3	Gray ring		

The Model CM4 will use one of the filter blocks shown in *Figure 9-7*. Note the positions of the filters for your type of filter block. The filter block is keyed to fit only one way into the instrument.

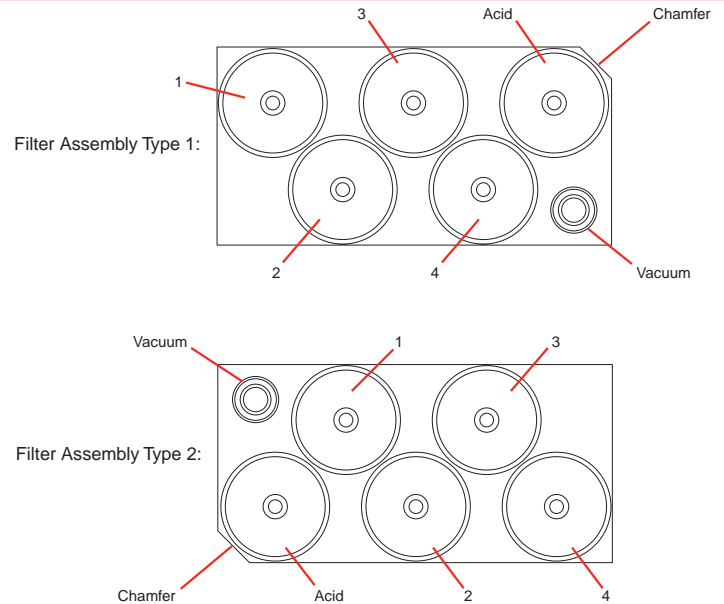

Figure 9-7: Filter Block Orientation

The following steps apply to all filters located within the CM4. Refer to these steps when performing maintenance on any filters in the system.

1. Open the tape load lever to the servicing position.
2. On older model CM4's, release carrier retaining clip by pressing toward rear of unit.
3. Remove the Chemcassette® carrier by placing your fingers under it, palms up, and lifting straight up. See [Figure 9-1](#) for proper procedure.

NOTE:

To avoid carrier torque and damage, do not tilt the carrier. Contact Honeywell Analytics if you are unable to remove the carrier.

4. Grasp the filter block handle (2) and pull out.
5. The filters are attached with a quick disconnect connector. Remove the filter by pressing the gray ring (3) against the fitting and sliding the filter out of the fitting.
6. Install the new filters by fully inserting the fittings. Filters have an arrow on the filter body indicating the direction of flow. The arrows should point toward the filter block. Be sure to orient the filters correctly
7. Reinstall the filter block (1).
8. Reinstall the Chemcassette® carrier and close the tape load lever.

9.3.2 Sample Line Particulate Filter

Sample line particulate filters prevent dust from entering through the sample line. Particulate filters are not recommended for all applications. See [Appendix A](#) for compatibility information. Replace the sample filter every three to twelve months.

Remove the old filter from the end of the sample line and attach a new filter. Install the filter so the arrow on the side of the filter points toward the CM4 tubing.

9.3.3 CM4-P Filter Maintenance



The pyrolyzer operates at a very high temperature. Before performing any service on the instrument, always wait 30 minutes after switching off power to allow the pyrolyzer to cool.

The filter block in the Model CM4-P is physically larger than the block in the standard Model CM4 (See Figure 9-8). Removing the filter block is the same as described in [Section 9.3.1](#), Internal Filter Replacement.

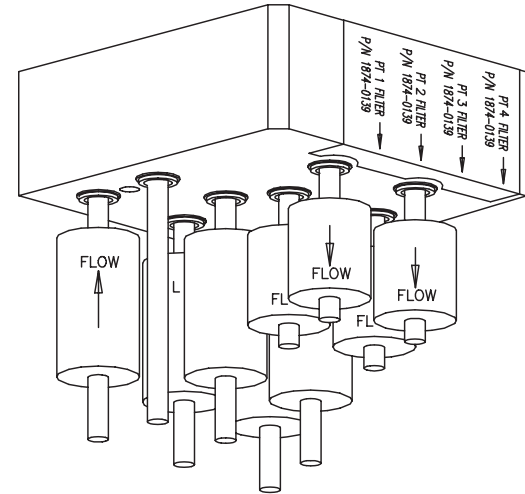

Figure 9-8: CM4-P Filter Block

There are nine filters in the CM4-P filter block: four charcoal for Freon® removal, four particulate, and one acid scrubber. The acid scrubber and particulate filters are identical to the standard Model CM4. The charcoal filters have a part number unique to the CM4-P: P/N 1874-0139. These filters are not interchangeable with other charcoal filters for removing Freon, such as those used on System 16.

Note the flow direction arrow when replacing the charcoal and particulate filters:

- Freon filters: arrow points away from the removable filter block
- Particulate filters: arrow points toward the removable filter block

Observe the following caution notice when performing maintenance and cleaning the filter block. This caution notice also applies to cleaning the optics block:

⚠ CAUTION

Do not use compressed air sources containing CFCs (chlorofluorocarbons). The CFCs may enter the pyrolyzer and be converted to HF/HCl when monitoring resumes. Also, do not permit the compressed air nozzle to come in direct contact with the instrument. Pressurizing the flow path could cause damage to the Model CM4-P.

Air Filter

⚠ CAUTION

Failure to maintain the air filter will result in eventual F19-OVERTEMP faults and loss of monitoring.

Model CM4-P has an air filter located on the lower right of the front panel, located where the flow control valves are on the standard Model CM4. This filter should be removed and cleaned (rinse with clean water and dry thoroughly) every 30 days.

9.4 Fuse Replacement

This section describes the AC line fuse. **Table 9-3** shows acceptable fuse values.

Voltage	Rating and Size	MDA P/N
CM4		
120 volt 60 Hz	3.15A SLO-BLO 5x20 mm	102531
100 volt 50/60 Hz	3.15A SLO-BLO 5x20 mm	102531
220/240 volt 50/60 Hz	2A SLO-BLO 5x20 mm	104708
CM4-P		
110/120 volt 60 Hz	5A SLO-BLO 5x20 mm	0170-0014
220/240 volt 50/60 Hz	4A SLO-BLO 5x20 mm	0170-0021

Table 9-3: Fuse Replacement

9.4.1 AC Line Fuse

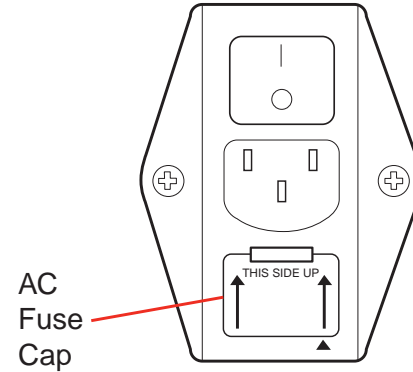

Figure 9-9: AC Fuse Cap

The CM4 is protected with a fuse located on the rear panel beneath the power cord.

To replace the AC line fuse:

1. Unplug the power cord.
2. With a slotted screwdriver, carefully pry the fuse cap outward.
3. Always replace fuses with the same type and style.
4. Replace the fuse cap.

NOTE:

A spare fuse is located on top side of fuse cap.

9.5 Cleaning the Chemcassette® Optics

See [Figures 9-10](#) and [9-11](#)

Clean Chemcassette® optics annually or whenever an optics verification error occurs.

Instructions

1. Turn off power to the CM4.
2. Open the tape load lever and remove the Chemcassette® carrier.
3. Unscrew two screws on the top panel and lift it. The panel pivots on studs as shown in [Figure 9-10](#).
4. Tighten the retaining knob to hold the panel open.
5. Release, then remove the pressure transducer port tubing from the optics block (see [Figure 9-11](#)).

NOTE:

Remove and clean one port at a time to ensure proper orientation of tubing. Do not remove the capillary tubing (microtubing).

6. Insert the tube of a small can of compressed air for optics cleaning into the port and spray for three or four seconds.
7. Reconnect the pressure transducer port tubing. Repeat steps 4, 5 and 6 for remaining ports.

CAUTION

Failure to replace and retighten hardware after servicing can adversely affect instrument performance and electromagnetic radiation compliance (EMC). Make certain all fasteners are reinstalled and firmly tightened. This will ensure a proper ground.

8. Close the panel and secure it with the screws.
9. Load the Chemcassette® carrier and close the load lever.
10. Turn on power to the CM4.

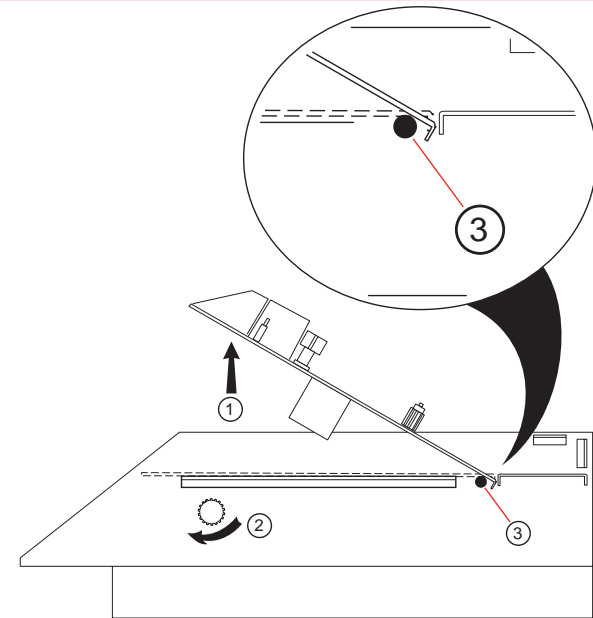

Figure 9-10: Accessing Chemcassette® Optics

Legend

1	Lift top panel	3	Studs
2	Tighten retaining knob on inside panel		

9.6 Installing Microtube Assembly

CAUTION

Make certain analyzer plate pivots on studs (3) when opening.

To access the Microtube Assembly:

1. Open the analyzer as indicated in steps 1-4, [Section 9.5](#).
2. Remove Microtube Assembly by unscrewing each end from optics block and filter manifold (3). See [Figure 9-11](#)

NOTE:

Remove one tube at a time to ensure proper orientation of tubing when reassembling.

3. Replace tubing. Firmly tighten fitting at each end.

NOTE:

Flow calibration will be affected by up to 20%. Contact Honeywell Analytics Service Department for calibration information.

CAUTION

Accidental exchange of any tube in this block may cause erroneous readings and improper system operation.

4. Perform leak test to verify system integrity. See [Appendix B.2](#) for leak test procedure.

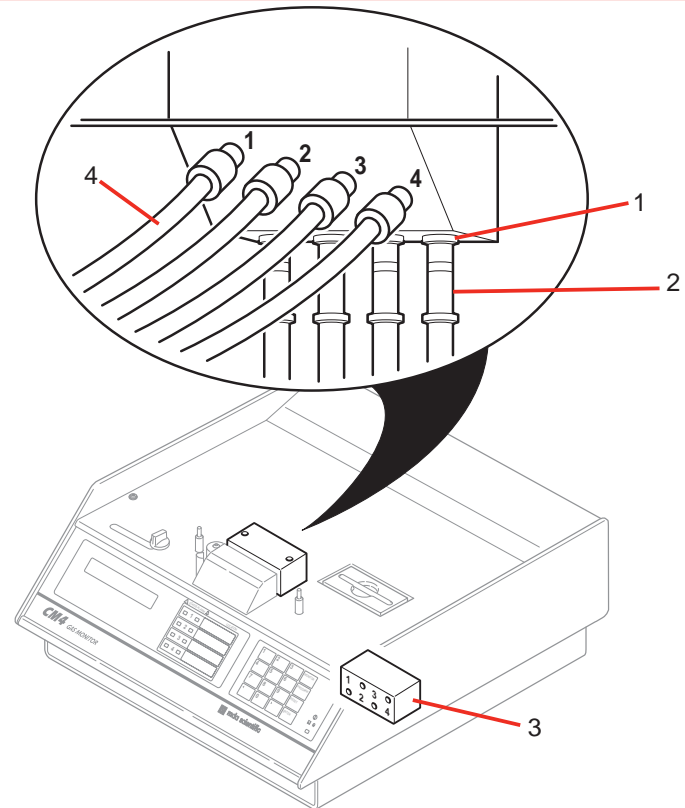

Figure 9-11: Microtube Assemblies

Legend

1	Release ring (push up on ring, pull down on tubing)	3	Filter manifold
2	Pressure transducer port tubing	4	Microtube assembly

10 Options

10.1 Communications Options

There are two optional communications features available for the CM4 monitor:

- Serial communications
- Printers

10.1.1 Serial Communications

The rear panels of the CM4 monitor allows installation of up to two optional serial interface ports. These ports are designed to allow output to printers and other devices, and two-way communication between the CM4 monitor and another device.

There are five serial interfaces available for the CM4 monitor, each designed for a specific communication application. The options are:

- RS-232 for serial printer or remote unidirectional ASCII interface (15 ft. max. distance)
- RS-232 for remote bidirectional binary communication
- RS-422 for serial printer or remote unidirectional ASCII interface
- RS-422 for remote bidirectional binary communication
- RS-485 for remote multi-drop bidirectional binary communication via two-wire transmission
- LONWORKS - a bus system that permits peer-to-peer communication information

The printer port is always unidirectional. The communications port is always bidirectional.

The serial communications ports are connected to the remote device(s) with 9-pin (DB9) plugs and cables. [Sections 7.4.1](#) and [7.4.2](#) provide information on selecting the communications ports.

For more detailed information on serial communications, request **Technical Note T/N 1998-0082** or [Appendix E, Serial Communications Protocol](#).

10.1.2 Printers

Up to nine CM4 monitors can send data to a single serial printer in a summary format. There are two printer options available, one for desktop and one for rack-mount applications. For complete instructions on the printer options, refer to [Appendix D](#), Printer Options.

10.2 Remote Alarm Reset Option

The remote alarm reset option provides the ability to reset the CM4 alarm conditions for any individual point from a remote location. There are two ways to connect the remote reset circuit:

- using an external 24V DC power supply
- using the CM4 unit's internal 24V DC system

The remote alarm reset option is factory-programmed with the purchase of the CM4 monitor. The factory-programmed setting must be performed by an authorized Honeywell field service engineer. External wiring, power supply, and switches are user-supplied items.

The following information will describe the two types of alarm reset circuits, wiring, and recommendations for installing an alarm reset system.

10.2.1 How it Works

The remote alarm reset option works similar to the reset button on the CM4 instrument. However, the remote option will allow resetting an alarm from individual points, while the reset button on the CM4 unit resets all alarms from all points at once. An additional advantage to the remote reset option is it can be located away from the CM4 unit. In an alarm condition, momentarily pressing (0.250 seconds minimum) the remote reset button will reset the individual point's alarm. This will also reset all fault indications on the instrument.

10.2.2 Wiring Considerations

WARNING

Removal of the cover over the Input/Output Module may expose hazardous voltages that are still present with power removed from the CM4 monitor. Ensure all wiring installation is performed by qualified personnel following all national and local electrical codes.

NOTE:

Units equipped with LonWORKS do not require an Input/Output module.

A major consideration in any remote application is the reduction of electrical interferences such as RFI or other electrical noise. Follow the guidelines below when choosing the wire and routing path for your remote reset switch location.

1. External wires should be either shielded twisted pair or individually shielded wires and should be rated at 600V for isolation. The remote alarm reset contacts draw approximately 25 mA/pt (100 mA for all four points). The loop resistance (wire and switch contact resistance) should be 2000 ohms per point maximum.
2. Do not run the alarm circuit wiring in the same conduit with wiring for inductive loads such as motor controls or AC loads and lines.
3. Use switches designed for low current applications, with normally open, momentary close contacts.
4. The back panel of the CM4 has been designed to allow low voltage wiring to exit from the unit from the right side (as you view the back panel) while higher voltage and AC wiring exits on the left. Keeping this wiring protocol reduces the risk of electrical noise causing interference to your alarm circuit. The remote inputs are located at the lower right of the relay panel as shown below.

10.2.3 Using an External Power Supply

The recommended method of wiring the remote alarm reset circuit is using an external (user-supplied) 24 VDC power supply. Using the external power supply provides a very efficient method of powering the alarm reset circuit, and reduces the risk of electrical interference within the CM4 monitor. A schematic of the circuit is shown in **Figure 10-1**.

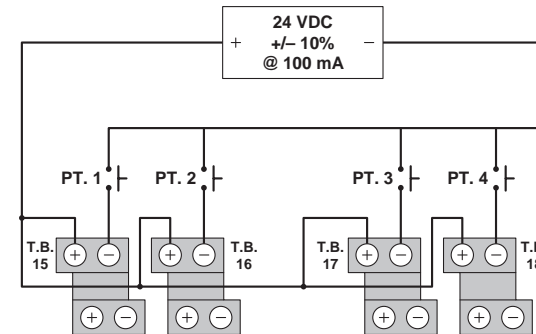

Figure 10-1: CM4 Circuit Schematic

10.2.4 Using the CM4 Monitor's Internal Power Supply

Another method of installing the remote alarm reset circuit utilizes the 24 VDC supply available from the CM4 monitor. While this method is usable for many applications, there are limitations to consider.

CAUTION

To ensure the CM4 monitor operates correctly, avoid EMI and RFI coupling circuits to the unit. Follow these guidelines when wiring external circuits:

- Do not connect the negative side of the remote reset terminal to building ground.
- Do not install wiring in the same conduit with any other circuitry.
- If properly grounded conduit is not used, a twisted pair shielded cable with the proper shield grounding techniques utilized must be used.

CM4 Four-Point Continuous Monitor

A schematic of the circuit using the CM4 monitor's internal 24 VDC power supply is shown in **Figure 10-2**.

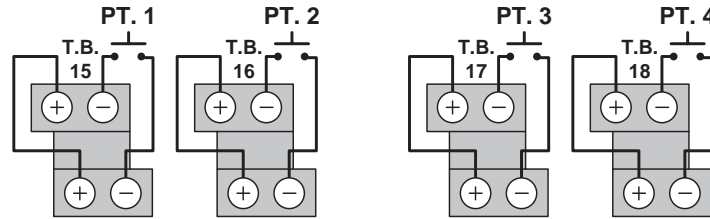

Figure 10-2: Using the CM4 Monitor Internal Power Supply

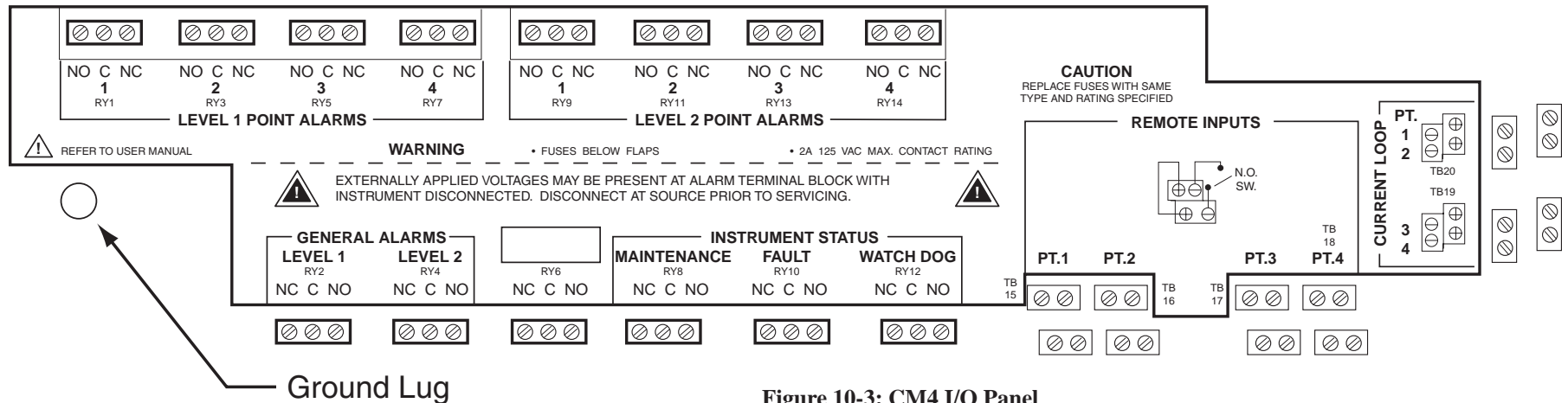

Figure 10-3: CM4 I/O Panel

10.3 Sample Line Integrity Option

The Sample Line Integrity Option is enabled as a factory setting. The instrument must have the appropriate and correct sensing hardware properly installed. If the hardware is defective or not present, the Model CM4 will display zero after the characterization has been completed.

The mode is enabled or disabled from the Service Mode menu. This menu is displayed only if the option has been factory-enabled.

Instructions

After installation, the feature is accessed through the Service function. To access the menu:

1. Press PROGRAM to exit Monitor Mode.
2. From the 4 – SERVICE MODE, choose the subfunction 8 – PUMP LIMITS then choose 3 – LIT (Line Integrity Test)

4 – SERVICE MODE

8 – PUMP LIMITS

3 – LIT

The display reads:

SELECT 1 ENABLE

SELECT 0 DISABLE

This will cause one of the following (example) serial printer messages:

10/24/00 17:44 CM4 - 123 - 0002

Line Integrity Test Disabled

or

10/24/00 17:44 CM4 - 123 - 0002

Line Integrity Test Enabled

Selecting ENABLE 1=Y enables the line check diagnostic. Once enabled, the Model CM4 establishes a baseline value for each sample line. It does this (with the pump off) by waiting 20 seconds and then taking 10 zero-readings on each of the four sample points. When complete, the Model CM4 switches the pump on, waits 10 seconds, and then takes an additional 10 zero-readings on each point. The difference between these values for each point is the baseline for each sample line.

The baseline variables (delta pressure and enable) are maintained in BBRAM (battery-backed RAM) and not in EEPROM fields. This means that they will be erased by Function 4.4 and also by installing new software.

While the baseline and pump profile measurements are being established, the Model CM4's display shows:

CHARACTERIZING

or

NOT AVAILABLE

If all the transducers read 0, the display will then indicate:

LIT SETUP DONE

The next display shows the delta counts for all four points as shown in this example:

108 77 79 91

The LIT (Line Integrity Test) maintenance fault has been assigned to Fault code 41. It is a maintenance fault with no yellow lights and no beeping (similar to the way Fault 40, Pyrolyzer Check Valve Leak is reported).

The Sample Line Integrity Check will periodically execute at or around the prescribed user-specified TWA times.

A Specifications

A.1 Introduction

Appendix A contains:

- End of line sample filter compatibility
- CM4 general specifications
- Sample transport times

A.2 Filter Compatibility

The following table shows sample filter requirements.

If you are monitoring non-corrosive target gases, use filter type A, (P/N 780248), a sample line dust/particulate filter.

For monitoring corrosive gases, such as chlorine (Cl₂), hydrogen fluoride (HF), hydrogen chloride (HCl), and hydrogen bromide (HBr), sample lines in a dusty environment or for outdoors, use filter type B, (P/N 1830-0055), or type C, (P/N 1991-0147) filter assembly for corrosive gases. The Teflon membrane particulate filter is designed to prevent dust and dirt greater than one micron from entering the sample line. Unlike standard particulate filters, it does not exhibit sample loss with corrosive monitoring.

The one micron Teflon membrane contained in the filter housing (P/N 0235-1072, 100 per pack) should be replaced every 30 days.

Filters have an arrow on the side of the filter pointing in the direction of airflow toward the CM4 system.

Filter	Part Number	Recommended Replacement
A	780248	3-6 Months
B	1830-0055	Filter membrane 0235-1072 monthly
C	1991-0147	3-6 Months

Symbol	Name	Filter Type A	Filter Type B	Filter Type C
AsH ₃	Arsine	X		
PH ₃	Phosphine	X		
B ₂ H ₆	Diborane	X		
SiH ₄	Silane	X		
GeH ₄	Germane	X		
TBA	Tert-butyl Arsine	X		
TBP	Tert-butyl Phosphine	X		
Cl ₂	Chlorine		X	X
NO ₂	Nitrogen Dioxide	X		
ClO ₂	Chlorine Dioxide		X	X
Cl ₂ LL	Chlorine (Low Level)		X	X
HCl	Hydrogen Chloride		X	X
HCl LL	Hydrogen Chloride (Low Level)		X	X
HF	Hydrogen Fluoride		X	X
HF LL	Hydrogen Fluoride (Low Level)		X	X
HBr	Hydrogen Bromide		X	X
HBr LL	Hydrogen Bromide (Low Level)		X	X
MMH	Monomethyl Hydrazine		X	X
NH ₃	Ammonia	X		
COCl ₂	Phosgene	X		
N ₂ H ₄	Hydrazine		X	X
H ₂ S	Hydrogen Sulfide	X		
HCN	Hydrogen Cyanide	X		
H ₂ S LL	Hydrogen Sulfide (Low Level)		X	X
COCl ₂ High	Phosgene High	X		
TEA	Triethyl Amine		X	X

Table A-1: Recommended Use of Sample Filter

Symbol	Name	Filter Type A	Filter Type B	Filter Type C
BF ₃	Boron Trifluoride		X	X
F ₂	Fluorine		X	X
TDMAT	Tetrakis(dimethylamino)titanium		X	X
H ₂ S Dry	Hydrogen Sulfide Dry	X		
H ₂ Se	Hydrogen Selenide		X	X
DMA	Dimethylamine		X	X
NF ₃	Nitrogen Trifluoride		X	X
UDMH	1,1 Dimethyl Hydrazine		X	X
CH ₃ F	Methyl Fluoride		X	X

Table A-1: Recommended Use of Sample Filter (cont'd)

A.3 General Specifications

A.3.1 CM4

Physical dimensions are as follows:

- Height: 9-3/16 inches (23.3 cm)
- Width: 17 inches (43.2 cm)
- Depth: 17-3/4 inches (45 cm)
- Weight: 55 pounds (25 kg)
- Mounting Table Top: Standard
- Wall Mount: Optional
- Rack Mount: Optional

Tubing dimensions are:

- Sample lines: 3/16-inch (4.7 mm) I.D. x 1/4-inch (6.35 mm) O.D. FEP Teflon, 300 ft. (90 m) maximum per point except for HBr LL 100 feet maximum per point, and N₂H₄ and MMH with 50 feet maximum.
- Exhaust line 3/16-inch (4.7 mm) I.D. x 1/4-inch (6.35 mm) O.D. tubing, 50 ft. (15m) maximum.

Output requirements are:

- 4-20 mA analog 100-800 ohms
- Relay output contacts:
Maximum: 127 VAC or 24 VDC @ 2 amps
Minimum: 24 VAC or 5 VDC @ 100 mA
- Installation Category (overvoltage category): II
- Operating Temperature: 50 - 104 °F (10-40 °C)
- Humidity: 20-80% RH

A.3.2 CM4-P

Physical dimensions are as follows:

- Height: 9-3/16 inches (23.3 cm)
- Width: 17 inches (43.2 cm)
- Depth: 18-3/4 inches (45 cm)
- Weight: 55 pounds (25 kg)
- Mounting Table Top: Standard
- Wall Mount: Optional
- Rack Mount: Optional

Tubing dimensions are:

- Sample lines: 3/16-inch (4.7 mm) I.D. x 1/4-inch (6.35 mm) O.D. FEP Teflon, 300 ft. (90 m) maximum per point except for HBr LL 100 feet maximum per point, and N₂H₄ and MMH with 50 feet maximum.
- Exhaust line 3/16-inch (4.7 mm) I.D. x 1/4-inch (6.35 mm) O.D. tubing, 50 ft. (15m) maximum.

Output requirements are:

- 4-20 mA analog 100-800 ohms
- Relay output contacts:
Maximum: 127 VAC or 24 VDC @ 2 amps
Minimum: 24 VAC or 5 VDC @ 100 mA
- Installation Category (overvoltage category): II
- Operating Temperature: 50 - 104 °F (10-40 °C)
- Humidity: 20-80% RH

A.4 Transport Times

Table A-2 shows the time required for samples to move from the sampling point to the CM4 for various lengths of sample lines.

Tubing Length	Time
20 feet (6 meters)	2 seconds
50 feet (15 meters)	5 seconds
100 feet (30 meters)	11 seconds
200 feet (61 meters)	23 seconds
300 feet (90 meters)	36 seconds

Table A-2: CM4 Nominal Transport Times

B Fault Listing

B.1 Fault Codes

Table B-1 lists the CM4 fault codes with possible cause(s) and corrective action(s).

Fault No.	Description	Possible Cause	Corrective Action	Relay Activated	Beeping Audio Alarm	Yellow Status LEDs
1	No Points Enabled	Programming Error	Enable Point in SET-UP (Section 7.2)	FAULT (RY10)	On	Solid
2	N/A					
3	BBRAM CSUM Error	Power Interrupted during Programming	Reset System (Section 8.5) Call Local Service Agent Note: If this fault appears, user-programmed information has reverted to factory-set selections.	FAULT (RY10)	On	Solid
4	Background Fail	Chemcassette® Expired Dirty Optics	Replace Chemcassette® (Section 9.2) Clean Optics (Section 9.5)	FAULT (RY10)	On	Solid
5	Tape Motor Fail	Motor not Operating Broken Chain Wire Disconnected Sensor Problem	Verify Motor Turns Verify Capstan Rotates Check Sensor/Magnet Position Reconnect Motor Wire to CPU Board Call Local Service Agent	FAULT (RY10)	On	Solid
6	Change Internal Filters	Filter Timer Expired	Replace Internal Filters (Section 9.3) and Reset Filter Timer (Section 9.2.1)	MAINT (RY8)	Off	Off
7	Change External Filters	Filter Timer Expired	Replace Sample Line Filters (Section 9.3) and Reset Filter Timer (Section 9.2.1)	MAINT (RY8)	Off	Off
8	Chemcassette® Low	Approximately 1-3 days of Chemcassette® remain	Replace Chemcassette® (Section 9.2)	MAINT (RY8)	Off	Off
9	Gate Open	Load Lever Open	Close Lever	FAULT (RY10)	Off	Solid

Table B-1: CM4 Fault Listings

Fault No.	Description	Possible Cause	Corrective Action	Relay Activated	Beeping Audio Alarm	Yellow Status LEDs
10	EE CSUM Error	EEPROM Error	Reset System (Section 8.5) Call Local Service Agent Note: If this fault appears vital, factory calibration information has been lost. Recalibration must be performed by a Local Service Agent.	FAULT (RY10)	On	Solid
11	Out of Monitor	Idle Time Expired	Return to Monitor Mode or Disable Timer (Section 7.6.5)	FAULT (RY10)	On	Solid
12	HI BACKGND 4 PTS	High background on all points Broken Tape in Carrier Dirty Optics	Find source of gas near optics block	FAULT (RY10)	On	Solid
13	Clock Error	Data Corrupted Clock Failure	Set Date and Time (Section 7.6.1) Call Local Service Agent	FAULT (RY10)	On	Solid
14	N/A					
15	N/A					
16	Optics Fail PTx	Communication problem between circuit boards	Check Controller cables Call Local Service Agent	FAULT (RY10)	On	Solid
17	Voltage Fail PTx	Ribbon cable unplugged Power Supply problem External short-circuit on 24 VDC	Check cable from CM4 to customer I/O module Call Local Service Agent Correct short and replace fuse (F15) on customer I/O board	FAULT (RY10)	On	Solid

Table B-1: CM4 Fault Listings (cont'd)

Fault No.	Description	Possible Cause	Corrective Action	Relay Activated	Beeping Audio Alarm	Yellow Status LEDs
18	Relay xx Fail	Cable problem Customer I/O relay board Circuit board	Check cable to customer I/O board Replace I/O relay board Replace controller board	FAULT (RY10) and FAULT (RY8)	On	Solid
19	Overtemp	Pyrolyzer or Optics Block-related malfunction	Check for dirty air filters Call Local Service Agent	FAULT (RY10)	On	Solid
20	Customer I/O 24V Fail	Blown Fuse Unconnected cable	Replace fuse Check cable connections	FAULT (RY10)	On	Solid
21	High Pyro Flow PTx	Sample flow exceeds 200 cc/min	Perform Checking Flow Rates (Section 9.2.5)	FAULT (RY10)	Off	Pulsed
22	Measurement and Control Board Fail	Measurement and control board disconnected Defective Measurement and Control board	Check Connections to Measurement and Control board Replace Measurement and Control board	FAULT (RY10)	On	Solid
23	Optics Shift PTx	Shift in optic light source	Check optics	MAINT (RY8)	Off	Off
24	Optics Verification Fail PTx	Verification card or Optics dirty	Clean card and repeat Verification Clean Optics (Section 9.5)	None	Off	Off
25	Pos Pressure PTx	Flow detected with pump off. Possibly induced by positive pressure at sample point	Point valve option should be installed	FAULT (RY10)	On	Solid

Table B-1: CM4 Fault Listings (cont'd)

Fault No.	Description	Possible Cause	Corrective Action	Relay Activated	Beeping Audio Alarm	Yellow Status LEDs
26	Pump Failure	<p>Pump Malfunction</p> <p>Set Pump Limits procedure not performed</p> <p>Pump inlet vacuum high, indicating filters clogged</p> <p>Pump exhaust pressure high, indicating blocked exhaust line</p> <p>Low line voltage</p>	<p>Cycle power</p> <p>Check pump limits (Section 8.9)</p> <p>Change internal filters (Section 9.6)</p> <p>Check operation with exhaust line disconnected to isolate problem</p>	FAULT (RY10)	On	Solid
27	Flow Failure PTx	<p>Point flow set incorrectly</p> <p>Chemcassette® not installed correctly</p> <p>Sample line kinked or obstructed</p> <p>Internal tubing, filter or valve clogged kinked or obstructed</p>	<p>Reset flow in Set Flow (Section 8.7)</p> <p>Reinstall Chemcassette® carrier (Section 9.2.4)</p> <p>Disconnect sample line if unable to flow balance</p> <p>Change internal filters (Section 9.6)</p>	FAULT (RY10)	On	
28	Lock On Time Out	<p>Point lock on exceeded idle time for remaining points</p>	<p>Disable points not desired (Section 7.2)</p> <p>Reprogram idle time out (Section 7.6.5)</p>	FAULT (RY10)	Off	
29	Unable to Print	<p>Printer not connected</p> <p>Printer not online</p> <p>Printer out of paper</p> <p>Data overload caused by “letter quality” selection on the printer</p>	<p>Make sure printer is connected</p> <p>Make sure printer is online</p> <p>Reload printer</p> <p>Make certain the printer is set on “draft quality” mode</p>	MAINT (RY8)	Off	
30	Print Overflow	<p>Print mode set to continuous</p> <p>Print mode set to “letter quality”</p>	<p>Change printer format to draft mode</p>	MAINT (RY8)	Off	
31	Gas Table Error	<p>Invalid gas table stored in EEPROM</p>	<p>Call Local Service Agent</p>	FAULT (RY10)	On	

Table B-1: CM4 Fault Listings (cont’d)

Fault No.	Description	Possible Cause	Corrective Action	Relay Activated	Beeping Audio Alarm	Yellow Status LEDs
32	Tape ADV ERR	Electrostatic discharge on circuit board Sensor problem	Cycle power Off then On Call Local Service Agent	FAULT (RY10)	On	
33	Opt. Unstable PTx	Ground noise in the installation Optics board set	Ensure proper grounding - check all connections Check board connections Call Local Service agent	FAULT (RY10)	On	
34	New PROM Detected	Software version has been revised or updated	Call Local Service Agent Note: If this fault appears, user-programmed information has reverted to factory-set selections	FAULT (RY10)	On	
35	Pyrolyzer Temperature Fail PTx	Defective heater, fuse or thermocouple	Call Local Service Agent	FAULT (RY10)	No	Pulsed
37	Transport Error	Tape is torn, spent or not correctly installed	Install replacement tape or reinstall tape	FAULT (RY10)	No	Solid
38	Transport Warning	Hub loose on sensor shaft Pending tape advance problem	Tighten hub on tape sensor shaft Call Local Service Agent	MAINT (RY10)	No	Off
39	Loss of Flow PTx	Tubing is blocked or plugged	Check sample lines Perform flow balance	FAULT (RY10)	No	Pulsed
40	Pyro Check Valve Failure PTx (CM4-P only)	Leaking check valve	Verify integrity of sample line Replace sample line	MAINT (RY8)	No	Off
41	Line Leak PTx	Leak in sample line	Verify integrity of sample line Replace sample line	MAINT (RY8)	No	Solid
42	Chemcassette® Expired	Chemcassette® past expiration date (continues monitoring - no accuracy guarantee) (See Table 8-2)	Replace Chemcassette®	MAINT (RY8)	No	

Table B-1: CM4 Fault Listings (cont'd)

Fault No.	Description	Possible Cause	Corrective Action	Relay Activated	Beeping Audio Alarm	Yellow Status LEDs
43	Chemcassette® Stale	Chemcassette® past “out-of-bag” expiration date (continues monitoring - no accuracy guarantee) (See Table 8-2)	Replace Chemcassette®	MAINT (RY8)	No	
44	Wrong Chemcassette® Type	Wrong Chemcassette® type for gas family	Replace with correct Chemcassette®	FAULT (RY10)	On	Solid
45	Chemcassette® Past Expiry	Chemcassette® past expiration date (stops monitoring) (See Table 8-2)	Replace Chemcassette®	FAULT (RY10)	On	Solid
46	Chemcassette® Very Stale	Chemcassette® past “out-of-bag” expiration date (stops monitoring) (See Table 8-2)	Replace Chemcassette®	FAULT (RY10)	On	Solid

Table B-1: CM4 Fault Listings (cont’d)

B.2 Leak Check Procedure

Purpose

Use the Leak Check procedure to verify leak integrity from the end of sample line to the optics block. All fittings, transducers connections and sample lines are verified leak tight to approximately 22 inches Hg (560 torr) of vacuum.

Items Required

- Flowmeter 0-5 Lpm with two lengths of 1/4-inch (6.35 mm) O.D. tubing attached (two 1/8 NPT to 1/4-inch fittings required)
- End of line plugs consisting of four 1/4-inch tube unions and five male plugs
- Sealing gasket to be installed in optics block (3.5 x 2 x .06 rubber)

NOTE:

Items required for performing a Leak Check should be available at most installation sites. Contact Honeywell Analytics service department for assistance in specifying or supplying parts needed.

Instructions

1. Press PROGRAM to exit Monitor Mode.
2. From the 4–SERVICE MENU, choose the subfunction 6–SET FLOW.

4 – SERVICE MODE

6 – SET FLOW

NOTE:

CM4 display ignored.

3. Open gate, remove Chemcassette and remove filter assembly.

4. Install gasket in optics and close load lever.
5. Install flowmeter as follows:
 - Connect tube “A” exiting top of flowmeter to vacuum supply (See **Figure B-1**)
 - Connect tube “B” exiting bottom of flowmeter, to desired point 1 to 4.

NOTE:

A full scale reading should be present.

6. Block the sample line of the same point your flowmeter is connected to using the union and plug.

NOTE:

Float in flowmeter will drop to 0 or oscillate, indicating a leak tight system.

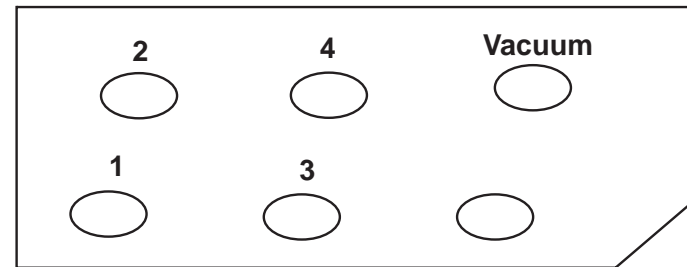

Figure B-1: Internal Manifold (Front/Top Edge)

7. Move tube “B” to next desired test point and repeat step 7.

NOTE:

Individual testing is recommended to ensure location is consistent with labeling.

8. Remove plug on completion of last point.

 **CAUTION**

Make sure end of line filters are in place where recommended.

NOTE:

If a leak is detected, the sample line can be exchanged for a plug isolating the problem to the tubing, unit or connection.

9. After procedure is complete, replace filter assembly, open gate and remove gasket.
10. Reinstall Chemcassette. Close gate and flow balance system before returning to Monitor Mode.

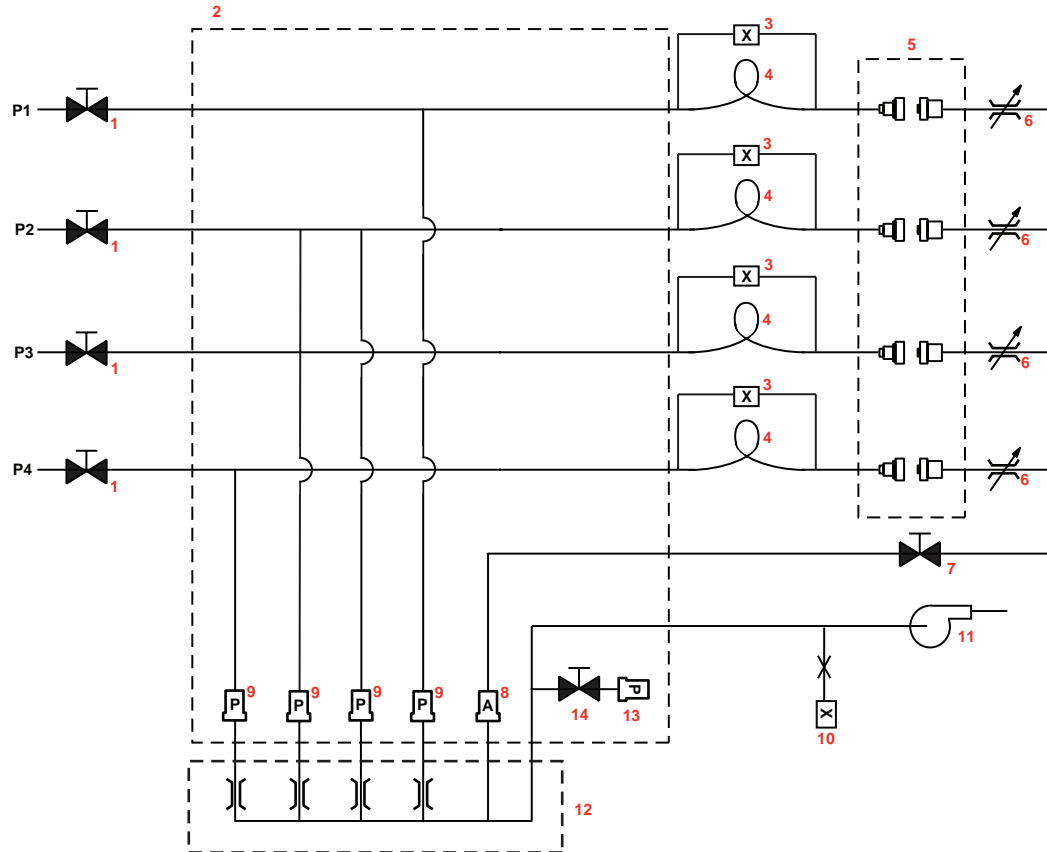

Figure B-2: CM4 Flow Diagram

Legend

1	Point shut-off valve/solenoid (optional)	6	Flow adjust	11	Pump
2	Sample manifold	7	Tape advance solenoid	12	Fast loop manifold
3	Vacuum transducer	8	Acid scrubber filter	13	Particulate filter fitting
4	Micro tube	9	Particulate filter	14	Pump start solenoid
5	Optics block	10	System vacuum (absolute) transducer		

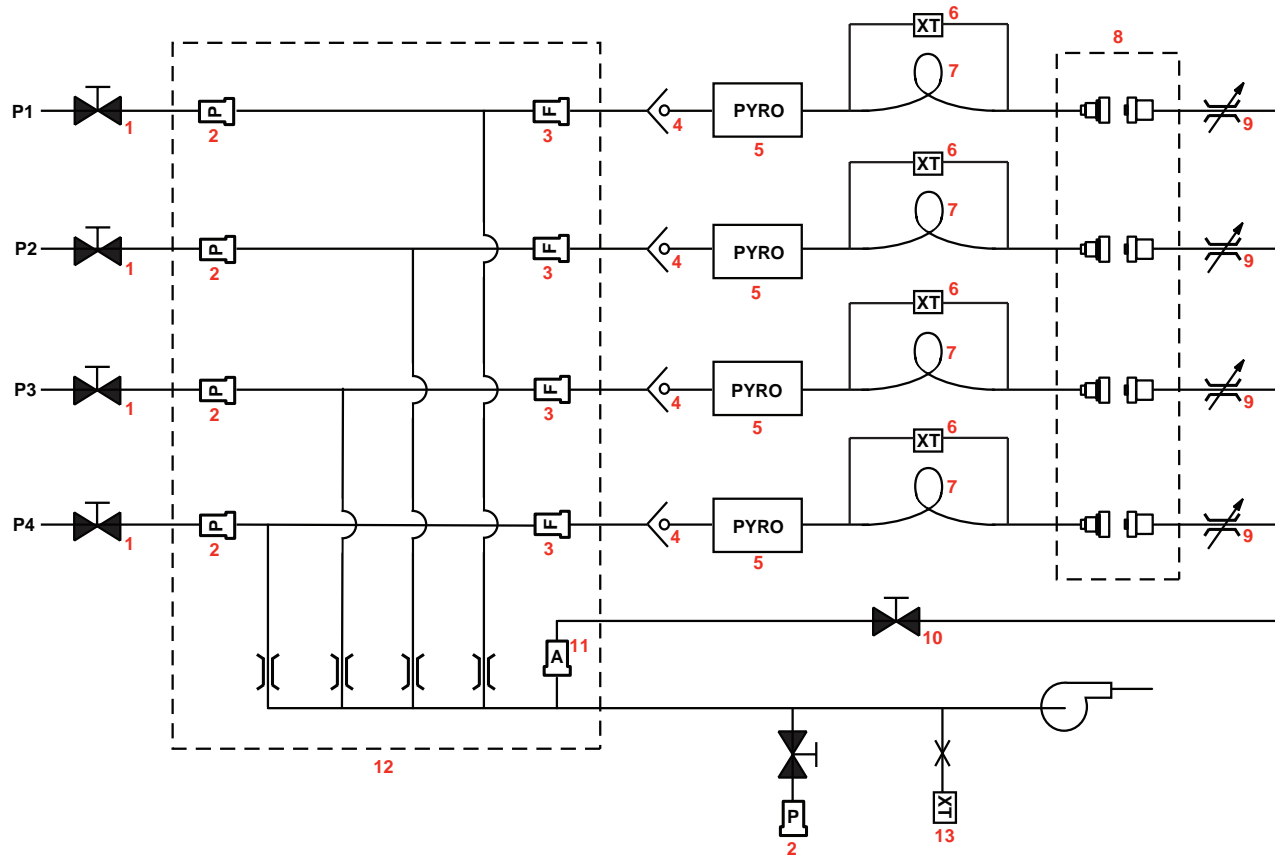

Figure B-3: CM4-P Flow Diagram

Legend

1	Point shut-off valve/solenoid (optional)	6	Vacuum transducer	11	Acid scrubber filter
2	Particulate filter	7	Micro tube	12	Fast loop manifold
3	Freon filter	8	Optics block	13	System vacuum (absolute)
4	Check valve	9	Flow adjust	14	Exhaust pump
5	Pyrolyzer	10	Tape advance valve		

**C Chemcassette[®] Detectable
Gases**

Gas Name	TLV	LAL	LDL	Default Alarm Level 1	Default Alarm Level 2	Range	Alarm Setting	Initial Analysis Period (seconds)	Time to 1 TLV Alarm @ 2 TLV Concentration 10 Foot Sample Line	Chemcassette Part Number	Chemcassette Label Color Code
Ammonia II (NH ₃)	25 ppm	3 ppm	3 ppm	25 ppm	50 ppm	3-75 ppm	3-49.9 ppm 50-75 ppm	10 5 5*	< 10 sec	874342	red, yel, lt blu
Ammonia XP (NH ₃) XP Ammonia/Amines	25 ppm	1.5 ppm	1.5 ppm	25 ppm	50 ppm	1.5-150 ppm	1.5-49.9 ppm 50-150 ppm	10 5	< 5 sec	1874-9309	red, lt grn, lt blu
Arsine (AsH ₃)	50 ppb	5 ppb	5 ppb	50 ppb	100 ppb	5-500 ppb	5-500 ppb	30 0*	< 10 sec	874300	red, gry, wht
Arsine (AsH ₃) Dry	50 ppb	7 ppb	5 ppb	50 ppb	100 ppb	5-500 ppb	7-99 ppb 100-199 ppb 200-500 ppb	60 30 15 1*	< 25 sec	874300	red, gry, wht
Arsine XP (AsH ₃)	50 ppb	3 ppb	2.5 ppb	50 ppb	100 ppb	2.5-500 ppb	3-500 ppb	30 0*	< 24 sec	1874-9300	red, gry, blu
Arsine XP (AsH ₃) Low Level	50 ppb	0.5 ppb	0.3 ppb	2.0 ppb	4.0 ppb	0.3-25 ppb	0.5-1.9 ppb 2-4.9 ppb 5-9.9 ppb 10-25 ppb	300 150 60 30 0*	< 150 sec	1874-9300	red, gry, blu
Boron Trifluoride (BF ₃) Low Level	1 ppm (ceiling)	120 ppb	100 ppb	250 ppb	500 ppb	100-1500 ppb	120-249 ppb 250-499 ppb 500-749 ppb 750-1500 ppb	240 120 60 30 5*	< 80 sec	874337	red, blu, brn
Boron Trifluoride XP (BF ₃)	1 ppm	0.2 ppm	0.1 ppm	1 ppm	2 ppm	0.1-10 ppm	0.1-0.4 ppm 0.5-0.9 ppm 1-10 ppm	75 45 30 5*	< 35 sec	1874-9310	red, gry, brn

Table C-1: Chemcassette Detectable Gases

* = Minimum Sample Time TLV = Threshold Limit Value LAL = Lowest Alarm Level LDL = Lower Detectable Limit

Gas Name	TLV	LAL	LDL	Default Alarm Level 1	Default Alarm Level 2	Range	Alarm Setting	Initial Analysis Period (seconds)	Time to 1 TLV Alarm @ 2 TLV Concentration 10 Foot Sample Line	Chemcassette Part Number	Chemcassette Label Color Code
Chlorine II (Cl ₂) Low Level	0.5 ppm	0.1 ppm	0.1 ppm	0.5 ppm	1 ppm	0.1-5 ppm	0.1-5 ppm	15 5*	< 15 sec	874007	red, yel
Chlorine (Cl ₂)	0.5 ppm	0.05 ppm	0.04 ppm	0.5 ppm	1 ppm	0.04-5 ppm	0.05-0.24 ppm 0.25-0.49 ppm 0.5-5 ppm	45 30 15 2*	< 15 sec	1874-9306	red, grn, yel
Chlorine XP (Cl ₂)	0.5 ppm	0.05 ppm	0.05 ppm	0.5 ppm	1 ppm	0.05-5 ppm	0.05-0.24 ppm 0.25-5 ppm	45 30 5*	< 24 sec	1874-9308	red, grn, lt blu
Chlorine XP Low Level (Cl ₂)	0.5 ppm	30 ppb	7 ppb	500 ppb	1000 ppb	7-2000 ppb	30-199 ppb 200-499 ppb 500-2000 ppb	120 90 60 0*	< 20 sec	1874-9308	red, grn, lt blu
Chlorine Dioxide (ClO ₂)	100 ppb	50 ppb	32 ppb	100 ppb	200 ppb	32-1000 ppb	32-99 ppb 100-199 ppb 200-399 ppb 400-1000 ppb	300 240 120 60 0*	<120 sec	1874-9306	red, grn, yel
Diborane (B ₂ H ₆)	100 ppb	20 ppb	15 ppb	100 ppb	200 ppb	15-1000 ppb	20-99 ppb 100-199 ppb 200-299 ppb 300-1000 ppb	60 45 30 15 5*	< 30 sec	874300	red, gry, wht
Diborane XP (B ₂ H ₆)	100 ppb	15 ppb	10 ppb	100 ppb	200 ppb	10-1000 ppb	15-49 ppb 50-99 ppb 100-1000 ppb	60 45 30 0*	< 30 sec	1874-9300	red, gry, blu

Table C-1: Chemcassette Detectable Gases (cont'd)

* = Minimum Sample Time TLV = Threshold Limit Value LAL = Lowest Alarm Level LDL = Lower Detectable Limit

Gas Name	TLV	LAL	LDL	Default Alarm Level 1	Default Alarm Level 2	Range	Alarm Setting	Initial Analysis Period (seconds)	Time to 1 TLV Alarm @ 2 TLV Concentration 10 Foot Sample Line	Chemcassette Part Number	Chemcassette Label Color Code
DiMethyl Amine (DMA)	5 ppm	0.4 ppm	0.3 ppm	5 ppm	10 ppm	0.3-30 ppm	0.4-2.4 ppm 2.5-4.9 ppm 5-30 ppm	120 60 30 5*	< 30 sec	874342	red, yel, lt blu
1,1 Dimethyl Hydrazine (UDMH)	10 ppb	5 ppb	3 ppb	10 ppb	20 ppb	3-5000 ppb	5-9 ppb 10-99 ppb 100-249 ppb 250-5000 ppb	360 120 30 15 5*	<120 sec	874347	red, wht, brn
Fluorine (F ₂)	1 ppm	0.1 ppm	0.06 ppm	1 ppm	2 ppm	0.06-10 ppm	0.1-0.99 ppm 1-10 ppm	60 30 5*	< 30 sec	1874-9306	red, grn, yel
Germane (GeH ₄)	200 ppb	100 ppb	100 ppb	200 ppb	400 ppb	100-2000 ppb	100-2000 ppb	240 5*	< 242 sec	874300	red, gry, wht
Germane XP (GeH ₄)	200 ppb	100 ppb	100 ppb	200 ppb	400 ppb	100-2000 ppb	100-149 ppb 150-199 ppb 200-2000 ppb	480 360 240 5*	< 240 sec	1874-9300	red, gry, blu
Hydrazine (N ₂ H ₄)	10 ppb	10 ppb	10 ppb	100 ppb	200 ppb	10-1000 ppb	10-14 ppb 15-19 ppb 20-1000 ppb	600 360 240 5*	< 360 sec	874347	red, wht, brn
Hydrogen Bromide (HBr)	2 ppm	0.5 ppm	0.3 ppm	2 ppm	4 ppm	0.3-30 ppm	0.5-2.9 ppm 3-5.9 ppm 6-8.9 ppm 9-30 ppm	45 30 15 10 2*	< 20 sec	874337	red, blu, brn

Table C-1: Chemcassette Detectable Gases (cont'd)

* = Minimum Sample Time TLV = Threshold Limit Value LAL = Lowest Alarm Level LDL = Lower Detectable Limit

Gas Name	TLV	LAL	LDL	Default Alarm Level 1	Default Alarm Level 2	Range	Alarm Setting	Initial Analysis Period (seconds)	Time to 1TLV Alarm @ 2TLV Concentration 10 Foot Sample Line	Chemcassette Part Number	Chemcassette Label Color Code
Hydrogen Bromide XP (HBr)	2 ppm	0.3 ppm	0.2 ppm	2 ppm	4 ppm	0.2-20 ppm	0.3-1.9 ppm 2-20 ppm	45 30 5	< 20 sec	1874-9310	red, gry, brn
Hydrogen Bromide (HBr) Low Level	2 ppm	100 ppb	50 ppb	500 ppb	1000 ppb	50-2000 ppb	100-249 ppb 250-499 ppb 500-749 ppb 750-2000 ppb	240 120 60 30 5*	< 60 sec (Alarm @ 500 ppb with 1000 ppb gas)	874337	red, blu, brn
Hydrogen Bromide XP (HBr) Low Level	2 ppm	30 ppb	20 ppb	200 ppb	400 ppb	20-2000 ppb	30-99 ppb 100-199 ppb 200-399 ppb 400-2000 ppb	180 120 120 60 5*	< 60 sec (Alarm @ 500 ppb with 1000 ppb gas)	1874-9310	red, gry, brn
Hydrogen Chloride (HCl)	2 ppm	0.5 ppm	0.5 ppm	2 ppm	4 ppm	0.5-15 ppm	0.5-9.9 ppm 10-15 ppm	30 20 0*	< 20 sec	874337	red, blu, brn
Hydrogen Chloride XP (HCl)	2 ppm	0.2 ppm	0.2 ppm	2 ppm	4 ppm	0.2-20 ppm	0.2-0.9 ppm 1-3.9 ppm 4-20 ppm	60 30 20 0*	< 15 sec	1874-9310	red, gry, brn
Hydrogen Chloride (HCl) Low Level	2 ppm	100 ppb	80 ppb	500 ppb	1000 ppb	80-8000 ppb	100-499 ppb 500-999 ppb 1000-2999 ppb 3000-8000 ppb	300 120 60 30 5*	< 20 sec	874337	red, blu, brn

Table C-1: Chemcassette Detectable Gases (cont'd)

* = Minimum Sample Time TLV = Threshold Limit Value LAL = Lowest Alarm Level LDL = Lower Detectable Limit

Gas Name	TLV	LAL	LDL	Default Alarm Level 1	Default Alarm Level 2	Range	Alarm Setting	Initial Analysis Period (seconds)	Time to 1 TLV Alarm @ 2 TLV Concentration 10 Foot Sample Line	Chemcassette Part Number	Chemcassette Label Color Code
Hydrogen Chloride XP (HCl) Low Level	2 ppm	30 ppb	20 ppb	200 ppb	400 ppb	20-2000 ppb	30-99 ppb 100-199 ppb 200-399 ppb 400-2000 ppb	300 150 60 30 0*	< 50 sec (Alarm @ 200 ppb with 400 ppb gas)	1874-9310	red, gry, brn
Hydrogen Cyanide (HCN)	4.7 ppm (ceiling)	1 ppm	0.5 ppm	4.7 ppm	9.4 ppm	0.5-30 ppm	1-2.4 ppm 2.5-30 ppm	30 10 1*	< 15 sec	874510	red, brn, yel
Hydrogen Fluoride (HF)	2 ppm	0.4 ppm	0.4 ppm	2 ppm	4 ppm	0.3-30 ppm	0.3-2.9 ppm 3-5.9 ppm 6-11.9 ppm 12-30 ppm	120 60 30 15 0*	< 55 sec	874337	red, blu, brn
Hydrogen Fluoride XP (HF)	2 ppm	0.4 ppm	0.4 ppm	2 ppm	4 ppm	0.2-20 ppm	0.2-0.9 ppm 1-3.9 ppm 4-20 ppm	240 90 60 0*	< 30 sec	1874-9310	red, gry, brn
Hydrogen Fluoride XP (HF) Low Level	2 ppm	30 ppb	20 ppb	500 ppb	1000 ppb	20-2000 ppb	30-199 ppb 200-399 ppb 400-2000 ppb	120 90 60 5*	< 35 sec (Alarm @ 500 ppb with 1000 ppb gas)	1874-9310	red, gry, brn
(Note: Due to U.S. Government regulations, this range may be subject to restrictions requiring special licensing for certain countries outside North America. Contact HA for eligibility information)											
Hydrogen Iodide (HI)	None Estab- lished	0.2 ppm	0.1 ppm	3 ppm	6 ppm	0.1-25 ppm	0.2-1.4 ppm 1.5-25 ppm	240 60 2*	< 20 sec	874337	red, blu, brn

Table C-1: Chemcassette Detectable Gases (cont'd)

* = Minimum Sample Time TLV = Threshold Limit Value LAL = Lowest Alarm Level LDL = Lower Detectable Limit

Gas Name	TLV	LAL	LDL	Default Alarm Level 1	Default Alarm Level 2	Range	Alarm Setting	Initial Analysis Period (seconds)	Time to 1TLV Alarm @ 2TLV Concentration 10 Foot Sample Line	Chemcassette Part Number	Chemcassette Label Color Code
Hydrogen Selenide (H ₂ Se) 20	50 ppb	8 ppb	6 ppb	50 ppb	100 ppb	6-500 ppb	8-49 ppb 50-99 ppb 100-500 ppb	180 120 60 5*	< 35 sec	874300	red, gry, wht
Hydrogen Selenide XP (H ₂ Se)	50 ppb	8 ppb	6 ppb	50 ppb	100 ppb	6-500 ppb	8-49 ppb 50-99 ppb 100-500 ppb	180 120 60 5*	< 100 sec	1874-9300	red, gry, blu
Hydrogen Sulfide (H ₂ S)	10 ppm	1 ppm	0.5 ppm	10 ppm	20 ppm	0.5-100 ppm	1-9.9 ppm 10-19.9 ppm 20-39.9 ppm 40-100 ppm	30 15 10 5 0*	< 10 sec	874304	red, lt grn, blu
Hydrogen Sulfide (H ₂ S) Hydrides	10 ppm	2 ppm	1 ppm	10 ppm	20 ppm	1-50 ppm	2-9.9 ppm 10-19.9 ppm 20-39.9 ppm 40-50 ppm	60 45 30 15 0*	< 10 sec	874300	red, gry, wht
Hydrogen Sulfide (H ₂ S) Low Level	10 ppm	10 ppb	8 ppb	500 ppb	1000 ppb	8-2000 ppb	10-99 ppb 100-499 ppb 500-999 ppb 1000-2000 ppb	480 240 120 60 0*	< 30 sec	874304	red, lt grn, blu
Hydrogen Sulfide (H ₂ S) XP Hydrides	10 ppm	1 ppm	0.5 ppm	10 ppm	20 ppm	0.5-50 ppm	1-4.9 ppm 5-9.9 ppm 10-50 ppm	30 15 5 0*	< 5 sec	1874-9300	red, gry, blu

Table C-1: Chemcassette Detectable Gases (cont'd)

* = Minimum Sample Time TLV = Threshold Limit Value LAL = Lowest Alarm Level LDL = Lower Detectable Limit

Gas Name	TLV	LAL	LDL	Default Alarm Level 1	Default Alarm Level 2	Range	Alarm Setting	Initial Analysis Period (seconds)	Time to 1 TLV Alarm @ 2 TLV Concentration 10 Foot Sample Line	Chemcassette Part Number	Chemcassette Label Color Code
Hydrogen Sulfide (H ₂ S) Low Level XP Hydrides	10 ppm	20 ppb	15 ppb	500 ppb	1000 ppb	15-1500 ppb	20-99 ppb 100-199 ppb 200-399 ppb 400-1500 ppb	120 60 30 15 5*	< 15 sec (Alarm @ 500 ppb with 1000 ppb gas)	1874-9300	red, gry, blu
Hydrogen Sulfide (H ₂ S) Dry XP Hydrides	10 ppm	1 ppm	0.5 ppm	10 ppm	20 ppm	0.5-50 ppm	1-4.9 ppm 5-9.9 ppm 10-50 ppm	30 15 5 0*	< 5 sec	1874-9300	red, gry, blu
Methyl Fluoride (CH ₃ F) CM4-P Only	None Established	12 ppm	10 ppm	25 ppm	50 ppm	10-100 ppm	12-24.9 ppm 25-100 ppm	120 60 5*	< 54 sec	874337	red, blu, brn
Monomethyl Hydrazine (MMH)	10 ppb	5 ppb	3 ppb	10 ppb	20 ppb	3-2000 ppb	5-19 ppb 20-2000 ppb	240 120 5*	< 240 sec	874347	red, wht, brn
Nitrogen Dioxide (NO ₂)	3 ppm	0.5 ppm	0.3 ppm	3 ppm	6 ppm	0.3-30 ppm	0.5-8.9 ppm 9-30 ppm	240 120 5*	< 234 sec	1874-9306	red, grn, yel
Nitrogen Trifluoride (NF ₃) CM4-P Only	10 ppm	1 ppm	1 ppm	10 ppm	20 ppm	1-50 ppm	1-9.9 ppm 10-19.9 ppm 20-39.9 ppm 40-50 ppm	40 20 10 5 0*	< 60 sec	874337	red, blu, brn
Nitrogen Trifluoride XP (NF ₃) CM4-P Only	10 ppm	1 ppm	1 ppm	10 ppm	20 ppm	1-50 ppm	1-9.9 ppm 10-19.9 ppm 20-39.9 ppm 40-50 ppm	30 15 10 5 0*	< 10 sec	1874-9310	red, gry, brn

Table C-1: Chemcassette Detectable Gases (cont'd)

* = Minimum Sample Time TLV = Threshold Limit Value LAL = Lowest Alarm Level LDL = Lower Detectable Limit

Gas Name	TLV	LAL	LDL	Default Alarm Level 1	Default Alarm Level 2	Range	Alarm Setting	Initial Analysis Period (seconds)	Time to 1 TLV Alarm @ 2 TLV Concentration 10 Foot Sample Line	Chemcassette Part Number	Chemcassette Label Color Code
Phosgene (COCl ₂)	100 ppb	10 ppb	7 ppb	100 ppb	200 ppb	7-1000 ppb	10-49 ppb 50-99 ppb 100-199 ppb 200-1000 ppb	60 45 30 15 2*	< 15 sec	874307	red, wht blu
Phosgene High Range XP (COCl ₂)	100 ppb	10 ppb	7 ppb	100 ppb	200 ppb	7-4000 ppb	10-49 ppb 50-99 ppb 100-199 ppb 200-4000 ppb	60 45 30 15 0*	< 15 sec	1874-9307	blk, red, brn
Phosgene XP (COCl ₂)	100 ppb	10 ppb	7 ppb	100 ppb	200 ppb	7-1000 ppb	10-49 ppb 50-99 ppb 100-199 ppb 200-1000 ppb	60 45 30 15 2*	< 15 sec	1874-9307	blk, red, brn
Phosphine (PH ₃)	300 ppb	5 ppb	5 ppb	300 ppb	600 ppb	5-3000 ppb	5-3000 ppb	15 0*	< 10 sec	874300	red, gry, wht
Phosphine XP (PH ₃)	300 ppb	5 ppb	5 ppb	300 ppb	600 ppb	5-3000 ppb	5-3000 ppb	15 0*	< 8 sec	1874-9300	red, gry, blu
Silane (SiH ₄)	5 ppm	1 ppm	0.5 ppm	5 ppm	10 ppm	0.5-50 ppm	1.04.9 ppm 5.0-9.9 ppm 10.0-19.9 ppm 20.0-50.0 ppm	60 45 30 15 5*	< 25 sec	874300	red, gry, wht

Table C-1: Chemcassette Detectable Gases (cont'd)

* = Minimum Sample Time TLV = Threshold Limit Value LAL = Lowest Alarm Level LDL = Lower Detectable Limit

Gas Name	TLV	LAL	LDL	Default Alarm Level 1	Default Alarm Level 2	Range	Alarm Setting	Initial Analysis Period (seconds)	Time to 1TLV Alarm @ 2TLV Concentration 10 Foot Sample Line	Chemcassette Part Number	Chemcassette Label Color Code
Silane XP (SiH ₄)	5 ppm	0.5 ppm	0.3 ppm	5 ppm	10 ppm	0.3-50 ppm	0.5-4.9 ppm 5.0-9.9 ppm 10-19.9 ppm 20-50 ppm	60 45 30 15 5*	< 20 sec	1874-9300	red, gry, blu
Silane XP (SiH ₄) Low Level	500 ppb	50 ppb	50 ppb	500 ppb	1000 ppb	50-5000 ppb	50-249 ppb 250-499 ppb 500-999 ppb 1000-5000 ppb	360 240 120 60 5*	105 sec	1874-9300	red, gry, blu
Tertiary-Butyl-Arsine (TBA)	50 ppb	15 ppb	12 ppb	50 ppb	100 ppb	12-500 ppb	15-49 ppb 50-99 ppb 100-199 ppb 200-500 ppb	120 60 30 15 5*	< 32 sec	874300	red, gry, wht
Tertiary-Butyl-Arsine XP (TBA)	0.5 mg/m ³ for arsenic (OSHA)	15 ppb	12 ppb	50 ppb	100 ppb	12-500 ppb	15-24 ppb 25-49 ppb 50-99 ppb 100-500 ppb	120 60 30 15 2*	< 35 sec (Alarm @ 50 ppb with 100 ppb gas)	1874-9300	red, gry, blu
Tertiary-Butyl-Phosphine XP (TBP)	None Established	80 ppb	75 ppb	300 ppb	600 ppb	75-2000 ppb	80-149 ppb 150-299 ppb 300-599 ppb 600-2000 ppb	240 120 60 30 5*	< 60 sec (Alarm @ 300 ppb with 600 ppb gas)	1874-9300	red, gry, blu
Tetrakis-DiMethyl-Amino-Titanium (TDMAT)	None Established	0.3 ppm	0.1 ppm	1.2 ppm	2.4 ppm	0.1-7.5 ppm	0.3-0.5 ppm 0.6-1.19 ppm 1.2-7.5 ppm	120 60 30 5*	< 30 sec (Alarm @ 1.2 ppm with 2.4 ppm gas)	874342	red, yel, lt blue

Table C-1: Chemcassette Detectable Gases (cont'd)

* = Minimum Sample Time TLV = Threshold Limit Value LAL = Lowest Alarm Level LDL = Lower Detectable Limit

D Printer Options

D.1 Overview

This addendum describes the components, installation, cabling, jumper settings, and set up for the CM4 printer options. An optional printer can print data for up to nine CM4 monitors. The available printers are for use in both desktop and rack mount configurations, and operate in a unidirectional RS-232 communication format. An RS-422 format is available for a single rack-mounted CM4 monitor communicating directly to a rack-mounted printer.

The printer serial interface option is factory-installed. Note that all CM4 monitors require a serial printer interface option to operate any printer. This addendum can serve as a checklist to ensure the printer options are correctly installed, cabled, and enabled.

The following is a description of each of the serial printer options available for the CM4 monitor.

D.1.1 RS-232C

(P/N 1874-0323, 1874-0324 or 874021-R)

This serial communications interface provides unidirectional RS-232C communications from the CM4 monitor to the printer or share box. A communications cable is connected to the printer port located on the rear panel of the CM4 monitor. The RS-232C interface has a maximum range of 50 feet using high quality shielded cable.

D.1.2 RS-422

(P/N 874023-R)

This serial communications interface provides unidirectional RS-422 communications from one CM4 monitor to an RS-422 printer or computer. A communications cable is connected to the printer port located on the rear panel of the CM4 monitor. The RS-422 interface has a maximum range of two kilometers using high quality shielded cable.

D.1.3 Desktop Printer

(P/N 874012)

The desktop printer has a pre-installed RS-232C adapter for serial interface. Also included with the option is the adapter cable (25 pin to 9 pin) necessary to connect the printer to the CM4 monitor, and the printer's Operating and RS-232C Adapter manuals.

NOTE:

Draft mode should be selected to prevent backup of data in the buffer.

D.1.4 Enclosure Printer Kit

(P/N MVIP2248)

The Enclosure Printer Kit option is designed for customer installation into a previously purchased Schroff enclosure. The kit includes an Okidata Model ML 320 Turbo with the serial interface and cable pre-installed. The kit also includes a paper catcher/storage unit which is mounted in the rack cabinet directly below the printer.

Switch settings allow the printer to operate with either an RS-232C or RS-422 interface.

D.1.5 Printer Share Box

A printer share box is required whenever more than one CM4 monitor is connected to a printer. The printer share box option is available for 120, and 230 Volts. [Table D-1](#) lists the printer share box part numbers.

The power plug may have to be replaced or a plug adapter may be required for use in some European countries.

NOTE:

All communications cables needed to connect the CM4 monitors are included with the printer share box. The printer share box manufacturer's Owner's and Reference Manuals are included.

Printer Share Boxes

Instrument Inputs	Operating Voltage	Part Number
6	120 VAC	1874-0007
6	230 VAC	1874-0008
11	120 VAC	1874-0010
11	230 VAC	1874-0011

Table D-1: Printer Share Box Part Numbers

NOTE:

Cabinets supplied by Honeywell Analytics include a transformer to convert customer-supplied power to 120 VAC. For these installations, share box 1874-0007 or 1874-0010 should be used.

D.2 Jumpers

The jumpers on the printer option board are factory-set for either single CM4 monitor to printer or multiple CM4 monitor to printer share box applications.

For single CM4 monitors connected directly to the printer, jumpers C, D, E, and F are used. For multiple CM4 monitors, jumpers A, B, G, and H are used, as shown below:

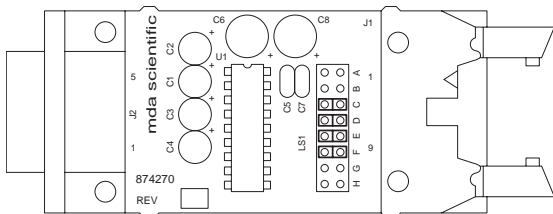

Serial Communications Interface Board.

For single CM4 monitors connected directly to an optional printer, the jumpers are set in positions C, D, E and F. This configures the CM4 as data communications equipment (DCE)

Figure D-1: Single CM4 Printer Connections

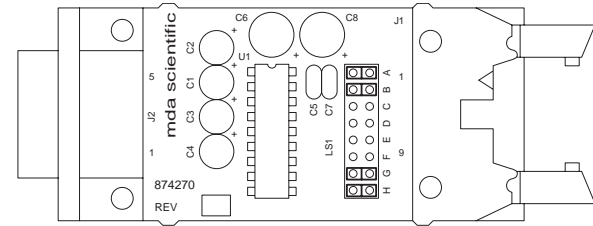

Serial Communications Interface Board.

For multiple CM4 monitors connected to a printer share box option, the jumpers are set in positions A, B, G and H. This configures the CM4 as data terminal equipment (DTE).

Figure D-2: Multiple CM4 Printer Connections

D.3 Cabling

D.3.1 EMC Considerations

The CM4 has been designed to comply with applicable EMC standards at the time of manufacture. The design includes filtering, shielding, and bypassing techniques. At the time of certification, simulated customer Input/Output (I/O) schemes were tested.

All methods used in your equipment for emission suppression and reduction of susceptibility are interactive. Modifications to the instrument will most likely result in increased emissions and higher vulnerability to other radiated fields.

Following the guidelines in this EMC Considerations section will ensure your instrument maintains the highest degree of EMC integrity. The guidelines listed apply only to I/O emissions, and do not apply to A.C. and D.C. instrument power connections.

Cabling

At a very minimum, all cables should include a braided shield. Ideal results have been obtained with twisted pair cabling which has a foil shield surrounding each pair plus foil and 90% braid shielding around the bundle. While this can be expensive, it yields the best results. In addition, ensure local electrical code requirements are met.

Cabling Type

The following cable parameters must be considered:

Braided Shield	Must have a minimum 90% coverage
Foil Shield	When used with braid, provides 100% coverage.

NOTE

Do not use foil alone. It has a tendency to break.

Twisted pair	Provides good immunity to magnetic pickup in RS-422 and RS-485 data lines.
Stranded Pair	Stranded wire Provides the greatest surface area. MDA Scientific product testing uses >90% braid with foil (around the bundle); twisted pair; stranded 24 AWG (minimum wiring for all qualification and certification testing). Examples: Belden 83652 2-conductor Belden 83653 3-conductor Belden 83654 4-conductor Belden 83656 6-conductor All examples are 18 AWG stranded, with 100% shield coverage
Shield Termination	Only one end of the shield is to be connected to earth ground. This connection is to be made at the Model CM4. Continuation of this shield to the earth ground is very important. For discrete wire terminations, pigtailed to the cabinet (connector) ground should be extremely short (absolutely no greater than three inches). For multiconductor connector terminations, only 360° shielded shells should be used.

Connectors

All qualification and certification of MDA Scientific products were achieved with high quality connectors, providing 360° shield coverage. These connectors generally had metal shells.

Failure to properly secure the connector to the equipment will result in high emission levels. Also, poorly constructed or improperly assembled connectors can be a high source of radiated noise, and provide a path for external signals into the instrument.

D.3.2 Cabling Diagrams

The following diagrams show the cabling configurations for single and multiple CM4 monitors connecting to one of the printer options. The cabling is identical for both desktop and rack mount installations.



CAUTION
Cabling used between the CM4 monitor and the external device must be shielded and properly grounded to maintain reliable operation and control RF emissions and susceptibility.

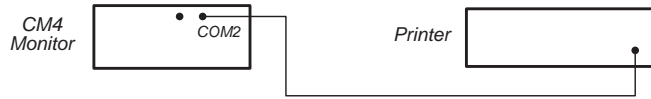

Single CM4 monitor and printer

Interface	RS-232 P/N 874201-R Rear Panel Mount
Jumpers	See Section D.2 for DCE jumper settings
Cable	For configurations with the Rack Mount Printer located in the same rack cabinet as the CM4 monitor, the interface cable (P/N 1874-0037, 9-pin to 25-pin, 10 ft.) is supplied. For distances to 50 ft. between the CM4 monitor and the Rack Mount Printer, order cable separately (P/N 1874-0031, 9-pin to 25-pin, 50 ft.). With the Desktop Printer, a 10 ft. interface cable is supplied (for connection between the CM4 monitor and the Desktop Printer). For customer-supplied cables, refer to the EMC Considerations section on page D-2 .
Printer	P/N 874012 Desktop or P/N 1874-0005 Rack Mount. These are 115 VAC printers. Other voltages for printers (rack mount only) are available as MVIP.
Notes	1. Maximum range: 50 Ft. 2. For Rack Mount Printer, set the printer switch to RS-232.

Figure D-3: Serial Interface, Single CM4, Single Printer

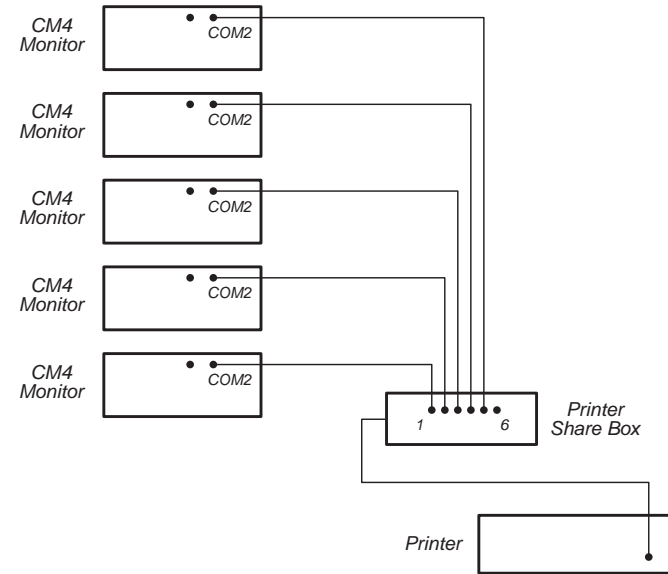

2 to 5 CM4 monitors and a single printer

Interface	RS-232 P/N 874201-R Rear Mount
Jumpers	See Section D.2 for DTE settings
Cables	The Printer Share Boxes listed on this page include the following cables: P/N 1874-0037 9-pin to 25-pin, 10 ft., qty 5, for connection between CM4 Monitors and Printer Share Box P/N 1991-0027 25-pin to 25-pin, 6 ft., qty 1, for connection between the Printer Share Box and Printer. For applications requiring a 50 ft. cable between the CM4 monitor and the Printer Share Box, order cables separately (P/N 1874-0031, 9-pin to 25-pin, 50 ft.). The Desktop Printer includes a 10 ft. interface cable for connection between the Printer Share Box and the Desktop Printer. For customer-supplied cables, refer to the EMC Considerations section on page D-2 .

Printer Share Box	<p>P/N 1874-0006 (100 VAC) or P/N 1874-0007 (120 VAC) or P/N 1874-0008 (230 VAC)</p> <p>NOTE</p> <p>Newer racks (P/N 1874-0050 and 1874-0051) transform the customer-supplied power to 120 VAC for the printer and share box. With these racks, only a 120 VAC share box (i.e. P/N 1874-0007) should be used.</p>
Printer	<p>P/N 874012 Desktop P/N 1874-0005 Rack Mount</p> <p>These are 115 VAC printers. Other voltages for printers (rack mount only) are available as MVIP.</p>
Notes	<ol style="list-style-type: none"> Maximum range: 50 Ft. For Rack Mount Printer, set the printer switch to RS-232.

Figure D-3: Serial Interface, 2-5 CM4s, Single Printer

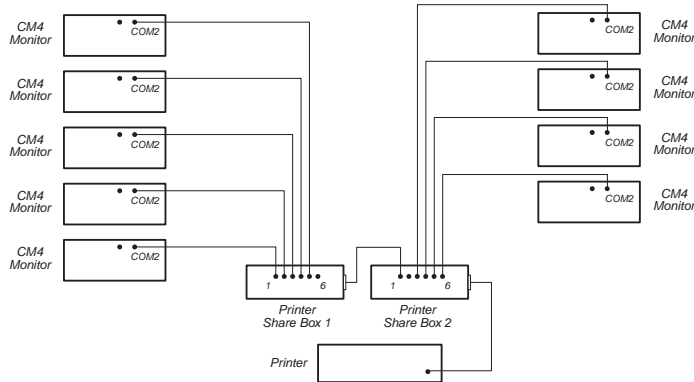

6 to 9 CM4 monitors and a single printer

Interface	RS-232 P/N 874201-R Rear Panel Mount
Jumpers	See Section D.2 for DCE settings

Cables	<p>The Printer Share Boxes listed on this page include the following cables:</p> <p>P/N 1874-0037 9-pin to 25-pin, 10 ft., quantity 9, for connection between CM4 monitors and Printer Share Box</p> <p>P/N 1991-0027 25-pin to 25-pin, 6 ft., quantity 1, for connection between the Printer Share Box and Printer.</p> <p>For applications requiring a 50 ft. cable between the CM4 monitor and the Printer Share Box, order cables separately (P/N 1874-0031, 9-pin to 25-pin, 50 ft.).</p> <p>The Desktop Printer includes a 10 ft. interface cable for connection between the Printer Share Box and the Desktop Printer.</p> <p>For customer-supplied cables, refer to the EMC Considerations section on page D-2.</p>
--------	---------------------------------------------------------------------------------------------------------------------------------------------------------------------------------------------------------------------------------------------------------------------------------------------------------------------------------------------------------------------------------------------------------------------------------------------------------------------------------------------------------------------------------------------------------------------------------------------------------------------------------------------------------------------------------------------------------------------------------------------

Printer Share Box	<p>P/N 1874-0006 (100 VAC) or P/N 1874-0007 (120 VAC) or P/N 1874-0008 (230 VAC)</p> <p>NOTE</p> <p>Newer racks (P/N 1874-0050 and 1874-0051) transform the customer-supplied power to 120 VAC for the printer and share box. With these racks, only a 120 VAC share box (i.e. P/N 1874-0007) should be used.</p>
Printer	<p>P/N 874012 Desktop P/N 1874-0005 Rack Mount</p> <p>These are 115 VAC printers. Other voltages for printers (rack mount only) are available as MVIP.</p>
Notes	<ol style="list-style-type: none"> Maximum range: 50 Ft. For Rack Mount Printer, set the printer switch to RS-232.

Figure D-4: Serial Interface, 6-9 CM4s, Single Printer

D.4 Instructions and Checklist

If your model CM4 was ordered with a serial printer interface, observe the following instructions to ensure the option(s) are installed, properly cabled, and enabled for printing.

Power:

Ensure that power to the CM4 monitor(s) and all options is Off. Do not connect or disconnect any cables with power applied to any units.

Cabling:

Check to ensure the cables are properly connected between the CM4 monitor(s), printer share box (if applicable), and printer.



Cabling used between the CM4 monitor and the external device must be shielded and properly grounded to maintain reliable operations and control RF emissions and susceptibility.

Printer Port:

Locate the printer port on the rear panel of the CM4 monitor cabinet. The printer port should be identified with a label. If the port is not identified, apply a label to the port to indicate the interface installed. On some units, the panel may be marked "PRINTER."

Enable the Printer Port:

Perform the following steps to enable the printer port. On the CM4 monitor(s):

1. Apply power to the CM4 monitor. Allow the monitor to perform its self-diagnostic testing, and wait until the unit has gone into the Monitor Mode.

2. Press PROGRAM to exit Monitor Mode.
3. From the 3 - SET-UP MODE, choose the subfunction 3 - OUTPUT OPTIONS, then select 2 - PRINTER PORT.

3 - SET-UP MODE

3 - OUTPUT OPTIONS

2 - PRINTER PORT

The display momentarily reads:

SET PRINTER PORT

The display then shows:

PRINTER PORT = ENABLE

4. Press CURSOR ARROW LEFT/RIGHT to toggle between enabling and disabling the printer (COM2) port. Select ENABLE and press ENTER.

The display reads:

PRINTER 9600 BD

5. You will now check the baud rate. Press CURSOR ARROW LEFT/RIGHT to advance the display through 1200, 2400, 4800, 9600, and 19200 baud.
6. When the display shows 9600 baud rate, press ENTER. The display shows:

BAUD RATE UPDATED

7. You will now enable the handshake. The handshake, when enabled, is used to indicate a printer time out fault on the maintenance relay. The display reads:

HW HANDSHAKE ENABLE

CM4 Four-Point Continuous Monitor

Press CURSOR ARROW LEFT/RIGHT to toggle between ENABLE and DISABLE. When the display shows ENABLE, press ENTER. The display will momentarily show:

HW HANDSHAKE ENABLED

NOTE:

HW Handshake is not used for RS-422 operation. No printer time out is issued. If you are using RS-422 option P/N 874023-R choose DISABLE and then press ENTER.

The display then returns to the output options function. Press reset to return to the instrument Set-up Menu.

For multiple instrument installations, repeat **Steps 1-7** for each CM4 monitor.

Select the Printer Format:

The CM4 monitor can send reports to a printer in three different formats:

- **Continuous Mode (CONT)** In this mode, all information is printed, including point concentrations for every sample period, alarm and fault data, and the 8-hour TWA.
- **Summary Mode (SUM)** This mode provides a printout of alarm and fault data and the TWA.
- **Compressed Mode (COMP)** This mode provides a printout of all point concentrations that exceed the lowest detectable limit, alarm and fault data, and TWA information. This is the default and the recommended mode.

One printer will sustain the output information of five CM4 monitors. However, if you are sending information from five CM4 monitors to a single printer, you should consider the type of report you wish to print. Five CM4 monitors operating in a continuous mode will send enough data to the printer to fill approximately 1200 sheets of paper

in a 24-hour period. Therefore, if you are operating continuously, we recommend you select either the Summary or Compressed Mode.

Follow these instructions to define the format of the printout:

1. Press PROGRAM to exit the Monitor Mode.
2. From the 3 - SET-UP MENU, choose the subfunction 3 - OUTPUT OPTIONS, then select 3 - PRINTER FORMAT.

3 - SET-UP MODE

3 - OUTPUT OPTIONS

3 - PRINTER FORMAT

The display reads:

SELECT REPORT

1=CONT 2=SUM 3=COMP

The cursor flashes over the current set-up selection.

3. Choose the type of report desired. Use the numeric keys to select 1, 2, or 3. The display will show:

PRINT FORMAT UPDATED

4. The CM4 monitor's software will automatically return to the Output Options menu.

Printer:

Make sure paper is properly loaded into the printer. Switch the printer On; perform any set-up procedures as required by the printer manufacturer. Consult the printer documentation for detailed instructions.

D.5 Other Applications

The serial printer interface is designed for unidirectional communication from a CM4 monitor to a single printer or other remote device. It is possible, therefore, that the application for this interface requires connection to a remote device other than the printer options described in this appendix.



CAUTION

Cabling used between the CM4 monitor and the external device must be shielded and properly grounded to maintain reliable operation and control RF emissions and susceptibility

For these applications, note the pin-out configuration in each of the diagrams.

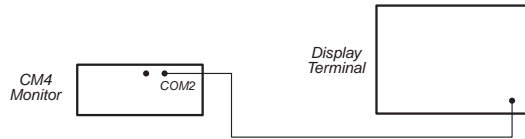

Single CM4 monitor to Display Terminal

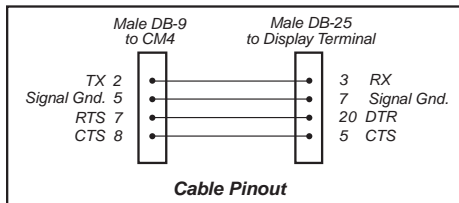

Cable Pinout

Note	Maximum range: 50 Ft.
Other Applications	<p>The serial printer interface is designed for unidirectional communication from a CM4 monitor to a single printer or other remote device. It is possible, therefore, that your application for this interface requires connection to a remote device other than the printer options described in this document.</p> <p>In this configuration, a terminal emulates the printer by displaying the ASCII text for concentrations, faults, and alarms on its screen. It is not possible to interrogate the Model CM4 through this printer port. Bidirectional communication is possible (not in ASCII) by using the CM4 serial communications port.</p> <p>The default setting (disabled) of the Model CM4's hardware flow control needs only two wires to be connected between the CM4 (Pin 2 and Pin 5) to the terminal.</p> <p>If you are connecting a device other than the printer options described in this technical note, use the following pin-out configuration on the connector cable. Also, refer to the EMC Considerations section on page D-2.</p>

Figure D-5: Serial Interface, Single CM4, Display Terminal

Interface	RS-232 P/N 874201-R Rear Panel Mount
Jumpers	See Section D.2 for DCE settings
Display Terminal	User-supplied
Cable	User-supplied. Refer to diagram for pin-out configuration. Also, refer to the EMC Considerations section on page D-2 .

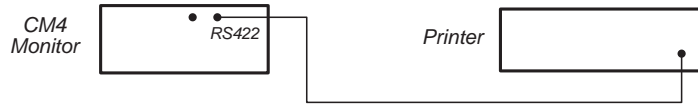

**Single CM4 monitor and printer
up to 4000 ft. distance**

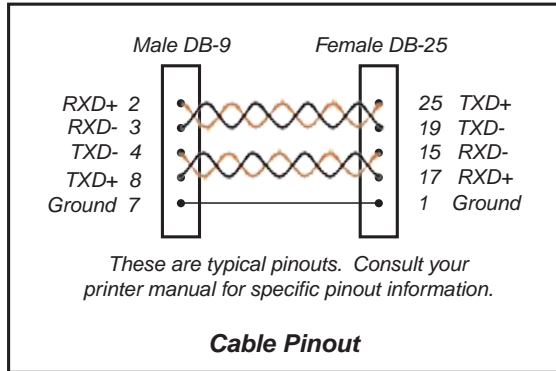

Interface	RS-422 P/N 874023-R Rear Panel Mount Refer to Section D.4 for installation checklist and programming instructions.
Printer	P/N 1874-0005 Rack Mount
Cable	Customer-supplied; refer to the EMC Considerations section on page D-2 . Use the connector cable pin-out configuration shown for RS-422 applications.

Figure D-6: Serial Interface, Single CM4, Single Printer up to 4000 ft. distance.

**E Serial Communications
Protocol**

E.1 Introduction

E.1.1 Overview

The CM4 serial communications protocol was designed and developed by Honeywell Analytics, and is proprietary information. This manual will describe the setup and operation of the communication protocol.

Your CM4 four-point continuous monitor is equipped with an optional serial remote device communication port. With this communication port, you can monitor the CM4 system's operation with equipment from a remote location. It will also allow you to gather gas concentration data for analysis or reports.

The CM4 monitor accepts commands and issues responses to any valid command it receives. The CM4 monitor is always considered the "slave" device, and the remote equipment is the "master" device. The remote equipment can be a personal computer (PC), a programmable logic controller (PLC), or other device capable of RS-232, RS-422, or RS-485 serial communications. This configuration requires a "master" device. Therefore, one CM4 monitor will not communicate directly with another CM4 monitor. However, one master can be used to communicate with more than one CM4 monitor on a two-wire RS-485 bus.

The CM4 monitor supports multiple baud rates. These user selectable rates are 1200, 2400, 4800, 9600, and 19,200. Additional port settings are 8-bit, 1 stop bit, and no parity.

The slave is identified by an address programmed into the CM4 monitor (selectable 1-255). If more than one CM4 monitor is used, each must have a unique address.

The equipment (master) is always at address 0. Each CM4 monitor will respond to a signal directed to it from the equipment. To prevent a collision of messages, the master must avoid transmitting any information after a packet until the slave responds. Typically this occurs within 1000 milliseconds.

E.1.2 Communication Port

Access to the CM4 protocol is through the COM port. This port is a DB-9 female connector. This port is designed for bidirectional communications between the CM4 instrument and your equipment.

Signals present at the port conform to RS-232, RS-422, or RS-485 specifications. Again, this is based on which interface option was installed in your CM4 instrument. The pin-out specifications for each option are as follows:

RS-232 (Part Number 874270)	
Pin Number	Signal
2	Transmit
3	Receive
5	Ground

RS-422 (Part Number 874326)	
Pin Number	Signal
2	Receive +
3	Receive -
4	Transmit -
5	Transmit +

RS-485 (Part Number 874556)	
Pin Number	Signal
2	B (Transmit/Receive +)
3	A (Transmit/Receive -)
7	Signal Ground

E.1.3 Set up Procedure

After the networking cabling has been connected to the slave, the slave must be configured to communicate. Baud rate, address, and protocol version are selectable. Configuration is performed with the following sequence:

<PROGRAM> <1> is pressed to stop monitoring.

SELECT PROGRAM < >

The keys 3 3 1 are pressed to go to the COM port setup menu.

SET COM PORT

One of the four protocol configurations must be selected.

COM PORT DISABLED

or

COM PROT VER 1

or

COM PROT VER 2

or

COM PROT LONWORKS

Protocol 1 is recommended for compatibility with existing master computers. Protocol 2 provides superior data integrity, but requires a change to the master. LONWORKS requires extra hardware. The selection is made by pressing <ENTER>.

COM PORT 9600 BAUD

Baud rates of 1200, 2400, 4800, 9600, and 19200 are available. 9600 baud is recommended for most applications. The selection is made by pressing <ENTER>.

SET INST. ADDRESS

INST. ADDRESS 001

Every slave on a network must have a unique address from 1 to 255. If only one slave is present, this value may remain at 1. After entering a unique number, press <ENTER>.

After these steps the COM port setup is complete. Normal operation is restored by pressing <MONITOR>.

E.1.4 Protocol Specifics

The protocol has been designed for flexibility and efficiency.

This byte-wise protocol communicates information by transferring bytes of data back and forth between master and slave. A group of bytes for each communication is called a packet.

The master and slave(s) transfer information via data packets. These packets will always contain bytes to start communication, an address, a packet length, a command, and a checksum.

Additional optional variable-length data bytes or optional parameters can also be sent or received. This section is a brief overview of the protocol specifics

Data and Packets

A byte is a piece of data. It is a way to indicate information and is composed of eight bits of information. A bit is the smallest possible piece of information. It can only be two possible values, 1 or 0 (True or False). A byte can have a decimal value from 0 to 255. In hexadecimal representation, a byte's value can range from 0x00 to 0xFF. Hexadecimal representation will be used for the remainder of this manual. The number may be interpreted in a manner other than a number, for example, as a letter.

Using ASCII characters, where 0x41 is the letter A, 0x42 is the letter B, 0x43 is C, and so on, a message can be written as these numbers. Each number is a byte. For example, the word "BAD" is 0x42, 0x41, 0x44.

The collection of the three bytes in our message (0x42, 0x41, 0x44) may be referred to as a packet, since these bytes are always associated with each other.

Just as all words are not the same length (number of letters), packets may also vary in length. One way to denote the size of the word is to put the number of letters you have in the word as the first number in your packet. Your data packet containing the word (or command) "BAD" will then become 0x03, 0x42, 0x41, 0x44.

Checksum (Check Character)

During transmission of the packet, an error could change the value of the data. Suppose in our example, for instance, the packet 0x03, 0x42, 0x41, 0x44 is actually 0x03, 0x42, 0x30, 0x44. How can you determine that the numbers you get are the same as the numbers sent? Using a check-character is a method of assigning a value to the packet to check if any bytes have been modified.

If all the data bytes are added together and this sum made into a byte, that byte could be called a check character, or more commonly referred to as a checksum. For the CM4 instrument, the checksum is the negated sum of all the bytes in the packet. In our example, the packet is 0x03, 0x42, 0x41, 0x44, 0x36. For this packet, the sum modulo 0x100 of all the bytes added to the checksum must equal zero (0). Any other result indicates there is an error with the data.

The slave's data contained within the packet is interpreted in a somewhat different manner than our example. The data is composed of two sections, a command and one or more parameters. The command indicates what type of information is being transmitted in the packet. The parameters contain specific arguments or data values to be interpreted. Parameters for most CM4 instrument's packet require at least four bytes for the Date and Time stamps. This information is important to provide a date and time reference for each communication

from the instrument. You should ensure that the date and time have been set accurately in each CM4 monitor.

Every packet sent by the CM4 instrument also contains an address, a length, a command and its associated parameters, and a checksum. The CM4 instrument assumes that the master's address is 0 (zero). You assign a unique address to each slave which communicates with the master.

ACK/NAK Handshake

Each slave (CM4) uses a handshake scheme between itself and the master. The simplest response back from the instrument is called an ACK (an abbreviation for ACKnowledge). When the slave receives a command packet from the equipment, it will send back an ACK response if the command is received, but no additional data has been requested in the command.

If however, the checksum does not match, the slave will send a NAK (an abbreviation for Negative AcKnowledge). A NAK indicates that a data packet has been received, but the checksum did not match with the packet data. The master may send the request again. An example of an ACK packet is 0x40, 0x00, 0x05, 0x20, 0x9B (40 + 0 + 5 + 20 + 9B = 0x100).

E.2 Protocol Packet Definition

E.2.1 Packet Format

Two similar protocols are supported by CM4 software. The original protocol with a minimum packet length of five bytes is included for compatibility with previous software. Additionally, a new protocol with a minimum packet length of six bytes is included for greater robustness. Examples of packets using both protocols are included at the end of this chapter.

The format of packets using original version 1 protocol is as follows:

start code	receiver address	length	command	data	checksum
------------	------------------	--------	---------	------	----------

The format of packets using the new version 2 protocol is similar:

start code	receiver address	transmitter address	length	command	data	checksum
------------	------------------	---------------------	--------	---------	------	----------

Start Code

Size: 1 byte. Always 0x40

Receiver Address

Size: 1 byte

For responses from slave to master, this is always 0.

For inquiries from master to slave, this must match the slave's address as set with menu function 3.3.1.

Transmitter Address

Size: 1 byte

For inquiries from master to slave, this is always 0.

For responses from slave to master, this will match the slave's address as set with menu function 3.3.1.

Length

Size: 1 byte

The length of the total packet from start code to checksum.

Command

Size: 1 byte

This is 0x28 to 0x69 as defined in the remainder of this book.

Data

Size: 0-250 byte(s)

This section varies according to the command chosen and is often empty.

Checksum

Size: 1 byte

The two's complement of the sum of all the previous bytes in the packet. This makes the sum of the entire packet a multiple of 0x100.

E.2.2 Generic Data Formats

Date Format

Size: 2 bytes

Year: (7 bits)

Month: (4 bits)

Day: (5 bits)

Year is based from 1980.

2005 would be 2005 - 1980 = 25.

Time Format

Size: 2 bytes

Hours: (5 bits)

Minutes: (6 bits)

Seconds/2: (5 bits)

Date/Time Examples

Date: 1F 56 Oct. 22. 2005

Date: 1F 75 Nov. 21, 2005

Time: 13 C0 02:30:00

Time: 74 23 14:33:06

Time: 4C 09 09:32:18

Concentration Data Format Code

U0XXYYYY

U = 0 concentration of PPB

1 concentration of PPM

0 = future use

XXX = future use

YYY = used for PPB/PPM (bit 7), and indicates where the decimal

place is located:

000 = no decimal places

001 = 1 decimal place

010 = 2 decimal places

011 = 3 decimal places

For example, (HEX) 82 (1000 0010) represents PPM with 2 decimal places.

For a concentration value of 317:

Format Code	Interpretation
0000 0010 (02)	3.17 PPB
1000 0010 (82)	3.17 PPM
0000 0000 (00)	317 PPB

E.3 Protocol Command Definition

E.3.1 Status and Query Commands

These commands indicate the function and expected response format for each command. Command numbers are in hexadecimal. If a specific response is required, the response packet will have the same command code as the command packet sent to the slave. If no specific response packet is specified, a general ACK response is sent to acknowledge the command.

NOP - 0x28

This is used to test for communication between the master and the specified slave.

Command packet to instrument:

Command Code (0x28) - 1 byte

Get System Information - 0x30

This packet requests information about the slave system only and the software version currently in use.

Command packet to instrument:

Command Code (0x30) - 1 byte

Response packet from instrument:

Command Code (0x30) - 1 byte

CM4 Date - 2 bytes

CM4 Time - 2 bytes

Serial # - 2 bytes, product code 851 is assumed.

Software Rev.

Major - 1 byte

Minor - 1 byte

VIP - 2 bytes - 0xFFFF as default

Prom Check Sums

MSB PROM - 2 bytes

LSB PROM - 2 bytes

Status - 1 byte

0x00 Read verified

0xff Error in reading

Software Rev. Examples

(Major/Minor/VIP):

01/07/FFFF - Rev. 1.07

03/0C/FFFF - Rev. 3.12

03/0C/0066 - Rev. 3.12-102

04/12/017A - Rev 4.18-378

Get Unit Status - 0x31

This command requests the current condition or status of the slave.
This command allows the master to inquire about the general operating condition of the system.

Command packet to instrument:

Command Code (0x31) - 1 byte

Response packet from instrument:

Command Code (0x31) - 1 byte

CM4 Date - 2 bytes

CM4 Time - 2 bytes

General Status - 2 bytes

bit 0: Current Operating mode

0 = Not monitoring

1 = Monitoring

bit 1: Keyboard Lockout state

0 = Disabled

1 = Enabled

bit 2: Key pad status

0 = unlock

1 = locked

bit 3: Chemcassette counter status

0 = Counter disabled

1 = Counter enabled

bit 4: 2mA Fault operation

0 = Feature disabled

1 = Feature enabled

bit 5: Point Lock-ON

0 = No Lock-ON

1 = Lock-ON

bits 6-7: Point Locked (Ignore if bit 5 is 0.)

00 = Point 1

01 = Point 2

10 = Point 3

11 = Point 4

bit 8: Date Format

0 = MM/DD/YY

1 = DD/MM/YY

bits 9-12: Points enable when No Lock on

0x01 = Point 1 enabled

0x02 = Point 2 enabled

0x04 = Point 3 enabled

0x08 = Point 4 enabled

bit 13: Relay state

0 = De-energized

1 = Energized

bit 14: Relay Latching state

0 = Non-latching

1 = Latching

bit 15: Alarm Simulation state

0 = Unit not in alarm simulation mode

1 = Unit in alarm simulation mode

New Events - 1 byte

bit 0: The alarm history contains an entry which has not been read via packet 0x36 or 0x47.

1 = a new entry exists

0 = no new entries

bit 1: The fault history contains an entry which has not been read via packet 0x3D

1 = a new entry exists

0 = no new entries

bits 2-7: undefined

Concentration Summary - 1 byte

bits 0-1: concentration summary integer (CSI) for point 1

bits 2-3: CSI for point 2

bits 4-5: CSI for point 3

bits 6-7: CSI for point 4

The CSI expresses the concentration relative to the alarm levels according to the following enumeration:

0 0.0 == concentration

1 0.0 < concentration < AL1

2 AL1 <= concentration < AL2

3 AL2 <= concentration

Chemcassette windows remaining - 2 bytes

Chemcassette days remaining - 2 bytes

Internal Filter 2 bytes (days in use)

External Filter - 2 bytes (days in use)

Flow Rate Point 1 - 2 bytes (cc/Min)

Flow Rate Point 2 - 2 bytes

Flow Rate Point 3 - 2 bytes

Flow Rate Point 4 - 2 bytes

Optics Cal Status - 1 byte

bit 0: Optics have been calibrated

0 = Not Tested

1 = Tested

bits 1-4: Optics test results

0x01 = Passed optics 1

0x02 = Passed optics 2

0x04 = Passed optics 3

0x08 = Passed optics 4

bits 5-7: Undefined

Maintenance Status

0x01 = low flow point 1

0x02 = low flow point 2

0x04 = low flow point 3

0x08 = low flow point 4

0x10 = low Chemcassette tape

0x20 = Maint. Relay

0x40 = Instr. Fault Relay

Get Idle Time - 0x32

This command inquires about how long the unit can be left out of analysis before setting an Instrument Fault. Idle time is used to notify operators that the unit is not monitoring. An idle time of 0 disables this option.

Command packet to instrument:

Command Code (0x32) - 1 byte

Response packet from instrument:

Command Code (0x32) - 1 byte

CM4 Date - 2 bytes

CM4 Time - 2 bytes

Idle Time - 1 byte (0 disabled, 1-45 min)

Status - 1 byte

0x00 = No errors in reading

0xff = Error in reading

Get Date & Time - 0x33

This command retrieves the current date and time from the unit.

Command packet to instrument:

Command Code (0x33) - 1 byte

Response packet from instrument:

CM4 Date - 2 bytes

CM4 Time - 2 bytes

Status - 1 byte

0x00 = Date and Time READ

0xff = Read problem

Get Maintenance Dates - 0x34

This command queries the maintenance items.

Command packet to instrument:

Command Code (0x34) - 1 byte

Response packet from instrument:

Command Code (0x34) - 1 byte

CM4 Date - 2 bytes

CM4 Time - 2 bytes

Last Power Down Date - 2 bytes

Last Power Down Time - 2 bytes

Last Power Up Date - 2 bytes

Last Power Up Time - 2 bytes

Flow Balance Date - 2 bytes

Flow Balance Time - 2 bytes

Optics Calibration Date - 2 bytes

Optics Calibration Time - 2 bytes

Date Chemcassette Replaced - 2 bytes

Time Chemcassette Replaced - 2 bytes

Date Int. Filter Replaced - 2 bytes

Date Ext. Filter Replaced - 2 bytes

Status - 1 byte

0x00 = No errors

0xFF = Error

Get Point Configuration - 0x35

This command queries an individual point for its current configuration.

Command packet to instrument:

Command Code (0x35) - 1 byte

Point Flag - 1 byte

bits 0-1: Point Number

00 = Point 1

01 = Point 2

10 = Point 3

11 = Point 4

bits 2-7: Undefined

Response packet from instrument:

Command Code (0x35) - 1 byte

CM4 Date - 2 bytes

CM4 Time - 2 bytes

Point Status Flag - 1 byte

bit 0: Point Enable/Disable bit

0 = Disabled

1 = Enabled

bits 1-2: Point locked status

00 = Normal (No point lock-on)

01 = Lock-on for this point

10 = Lock-on for another point

11 = Undefined

bits 3-7: Undefined

MDA Gas Abbr. - 6 bytes (not null terminated)

Gas Table number - 1 byte (0 is the first table)

Format Code - 1 byte

Alarm Level 1 - 2 bytes

Alarm Level 2 - 2 bytes

20 mA - 2 bytes

Full Scale - 2 bytes

Point ID - 20 bytes

Status - 1 byte

0x00 = Point read

0xff = Error

Get Alarm History - 0x36

This command queries the unit for any alarms. The unit saves only the 16 most recent alarms regardless of point. The alarms can all be on one point or there can be alarms from several points.

Command packet to instrument:

Command Code (0x36) - 1 byte

Response packet from instrument:

Command Code (0x36) - 1 byte

CM4 Date - 2 bytes

CM4 Time - 2 bytes

of Alarms - 1 byte

(alarm data, up to 16 possible)

CM4 Date of Alarm - 2 bytes

CM4 Time of Alarm - 2 bytes

Gas Abbr. 6 bytes

Point # - 1 byte

bits 0-1: Point #

00 = Point 1

01 = Point 2

10 = Point 3

11 = Point 4

bits 2-7: Undefined

Format Code - 1 byte

Conc. - 2 bytes

Alarm Level - 1 byte

bit 0: Alarm Level

0 = Level 1

1 = Level 2

bits 1-5: Undefined

bit 6: Previously Read

0 = new (not previously read)

1 = old (previously read)

bit 7: Undefined

Get Current Point Status - 0x37

This command queries an individual point for its current status.

Command packet to instrument:

Command Code (0x37) - 1 byte

Point # - 1 byte

bits 0-1: Point #

00 = Point 1

01 = Point 2

10 = Point 3

11 = Point 4

bits 2-7: Undefined

Response Packet from instrument:

Command Code (0x37) - 1 byte

CM4 Date - 2 bytes

CM4 Time - 2 bytes (If point is Disabled/Invalid/locked out, fill with zeroes)

MDA Gas Abbr. - 6 bytes (not null terminated)

Format Code - 1 byte

Flow Rate - 2 bytes (current flow)

TWA Start Date - 2 bytes

TWA Start Time - 2 bytes

TWA End Date - 2 bytes

TWA End Time - 2 bytes

TWA Conc. - 2 bytes

Last Conc. - 2 bytes (last reported conc.)

Alarm Status - 1 byte (0 none, 1 or 2 level) (Fill for all conditions)

Status - 1 byte

0x00 = Data valid

0x01 = Point Disabled (no data filled)

0x02 = Point Locked Out (no data filled)

0x04 = No TWA calculated

0x08 = No concentration available

0x10 = Alarm Simulation mode active

0xff = Invalid data

Get TWA Time - 0x38

This command queries the three TWA output time in a 24-hour format. Each of the TWA times are eight hours apart.

Command packet to instrument:

Command Code (0x38) - 1 byte

Response packet from instrument:

Command Code (0x38) - 1 byte

CM4 Date - 2 bytes

CM4 Time - 2 bytes

TWA time 1 - 2 bytes

TWA time 2 - 2 bytes

TWA time 3 - 2 bytes

Status - 1 byte

0x00 = Time read

0xff = Error in reading

Get Display Cycle Time - 0x39

This command queries for the length (in seconds) that the concentration for each point is displayed while the unit is in the Monitoring mode.

Command packet to instrument:

Command Code (0x39) - 1 byte

Response packet from instrument:

Command Code (0x39) - 1 byte

CM4 Date - 2 bytes

CM4 Time - 2 bytes

Cycle Time - 1 byte

(valid 2-10 sec., default 4 sec.)

Status - 1 byte

0x00 = No error

0xff = Error

Get the Number of Gas Tables Available - 0x3A

This command allows you to query the unit for the number of loaded gas tables in the unit.

Command packet to instrument:

Command Code (0x3A) - 1 byte

Response packet:

Command Code (0x3A) - 1 byte

CM4 Date - 2 bytes

CM4 Time - 2 bytes

of Gas Tables - 1 byte (1-255)

Get Printer Setup - 0x3B

This command queries the unit for the printer configuration.

Command packet to instrument:

Command Code (0x3B) - 1 byte

Response packet from instrument:

Command Code (0x3B) - 1 byte

CM4 Date - 2 bytes

CM4 Time - 2 bytes

Setup Status - 1 byte

bit 0: Printer port enable/disable

0 = Disable

1 = Enable

bits 1-2: Printer report format

00 = Continuous

01 = Summary

10 = Compressed

11 = Invalid

bits 3-5: Printer baud rate

000 = 1200

001 = 2400

010 = 4800

011 = 9600

100 = 19200

bit 6: Printer hardware handshaking (flow control)

0 = Disabled

1 = Enabled

bit 7: Undefined

Get Gas Table Data - 0x3C

This command allows you to view individual gas tables that are contained within the system.

Command packet to instrument:

Command Code (0x3C) - 1 byte

Gas to table to retrieve - 1 byte (0-255)

Response packet from instrument:

Command Code (0x3C) - 1 byte

CM4 Date - 2 bytes

CM4 Time - 2 bytes

(filled with zeroes if error)

MDA Gas Abbr. - 6 bytes (not null terminated)

Full Scale - 2 bytes

TLV - 2 bytes

LAL - 2 bytes

LDL - 2 bytes

Format Code - 1 byte

Revision # - 1 byte (1-255) (always filled)

Status

0x00 = Read OK

0x01 = Invalid Gas # index

0xff = Bad read

Get Fault History - 0x3D

This command will query the unit for the latest fault(s). There can be as many as four and as few as zero faults. General system faults are indicated by bit 0 of the point status byte. If bit 0 is set to 1, bits 1-2 should be ignored. The point status byte is invalid for Fault 17 (Voltage Fail) and Fault 18 (Relay Fail).

Command packet to instrument:

Command Code (0x3D) - 1 byte

Response packet from instrument:

Command Code (0x3D) - 1 byte

CM4 Date - 2 bytes

CM4 Time - 2 bytes

of faults - 1 byte (0-4 maximum) (fault data, maximum of four possible)

Date of fault - 2 bytes

Time of fault - 2 bytes

Fault # - 1 byte

Point Status - 1 byte

bit 0: General fault bit

0 = point specific

1 = general

bits 1-2: Point # where fault occurred

(ignored if bit 0 is 1 and for Flts 17 and 18)

00 = Point 1

01 = Point 2

10 = Point 3

11 = Point 4

bits 3-5: Undefined

bit 6: Previously Read

0 = new (not previously read)

1 = old (previously read)

bit 7: Instrument Fault

0 = maintenance fault -- the CM4's ability to monitor *is not* compromised.

1 = instrument fault -- the CM4's ability to monitor *is* compromised.

Get K-Factor - 0x3E

This command will inquire about K-Factor settings for all points. An individual point is assigned with a K-Factor times 1000 (a K-Factor of 1.000 is sent as 1000). The K-Factor is used to change the sensitivity of a point in the range of 0.200-5.000. This adjustment is made after the calculation of concentration.

Command packet to instrument:

Command Code (0x3E) - 1 byte

Response packet from instrument:

Command Code (0x3E) - 1 byte

CM4 Date - 2 bytes

CM4 Time - 2 bytes

K-Factor (x 1000) Point 1 - 2 bytes

K-Factor (x 1000) Point 2 - 2 bytes

K-Factor (x 1000) Point 3 - 2 bytes

K-Factor (x 1000) Point 4 - 2 bytes

Status

0x00 = Point read

0xff = Read problem

Get Pyrolyzer Temperatures - 0x42

This command returns the temperatures of the four pyrolyzers, in integer degrees Celsius the slave's internal temperature. This is applies to a model **CM4-P ONLY**.

Command Packet to slave:

Command Code (0x42) - 1 byte

Response from slave:

Command code (0x42) - 1 byte

CM4 date - 2 bytes

CM4 time - 2 bytes

pyrolyzer temp pt1 - 2 bytes

pyrolyzer temp pt2 - 2 bytes

pyrolyzer temp pt3 - 2 bytes

pyrolyzer temp pt4 - 2 bytes

Status - 1 byte (always 0x00 as implemented)

Get Pump Limits - 0x43

This command returns the user's settings for pump limits.

Command Packet to slave:

Command Code (0x43) - 1 byte

Response from slave:

Command code (0x43) - 1 byte

CM4 date 2 bytes

CM4 time 2 bytes

High Limit - 2 bytes (defaults to 600)

Low Limit - 2 bytes (defaults to 400)

Status - 1 byte (always 0x00 as currently implemented)

Get Filter Life - 0x44

This command returns the user's settings for total filter lifetime. Lifetime is set by the user to indicate how often the filters should be changed. A maintenance fault will be issued when the filters are this old. The valid range is 30 to 365 days. Zero lifetime means a filter maintenance.

Command Packet to slave:

Command Code (0x44) - 1 byte

Response from slave:

Command code (0x44) - 1 byte

CM4 date - 2 bytes

CM4 time - 2 bytes

Internal filter life - 2 bytes

External filter life - 2 bytes

Status - 1 byte (always 0x00 as currently implemented)

Get Floating Status - 0x45

This packet returns general information about the slave. It combines the information of packet 0x37 (Get Point Status) and 0x31 (Get Unit Status). However, it reports the concentration in IEEE floating-point format instead of as a scaled integer. Since it provides information that would otherwise require five interrogations, this should permit faster polling of slaves on a multidrop RS-485 bus.

Command Packet to Slave:

Command Code (0x45) - 1 byte

Response from Slave:

Command code (0x45) - 1 byte

CM4 date - 2 bytes

CM4 time - 2 bytes

Status - 1 byte

0x01 - in monitor

0x02 - maintenance fault relay activated

0x04 - instrument fault relay activated

0x08 - (1 bit) undefined

0x10 - A new fault has occurred since the last time packet 0x3D (Get Fault History) was requested.

0x20 - A new alarm has occurred since the last time packet 0x36 (Get Alarm History) was requested.

0xC0 - (2 bits) undefined

(The 7 byte Point Structure repeats 4 times)

Concentration - 4 byte floating point

Number in PPM

Flow - 2 byte integer in CC/min

Point status - 1 byte

0x01 - point disabled in config

0x02 - point disabled now (It may have become disabled because of a fault.)

0x04 - point locked out

0x08 - low flow

0x30 - (2 bits) concentration summary integer. The meaning of this field is as follows:

00: 0.0 == Concentration

01: 0.0 < Concentration < AL1

10: AL1 <= Concentration < AL2

11: AL2 <= Concentration

0xC0 - (2 bits) current alarm level

00: no alarm

01: alarm level 1 active

10: alarm level 2 active

(End of Point Structure)

Total size is 34 bytes

Example

The following example is an illustration of the above packet using serial communication protocol version 2. The address of the slave is 42 (0x2A). Point 1 is in a level 2 alarm, but the gas concentration has decreased below AL2 and AL1 to 42.2 ppb. The other three points are reading zero concentration. The instrument fault relay is activated and point 4 is disabled because of loss of flow. Both the Fault History and the Alarm History have new entries which have not been read yet. Point 3 is configured to be disabled via menu function 3.1. All four flows are near the norm of 180 cc/min except for point 4, which is 139 cc/min.

Master:	40 2A 00 06 45 4B;	inquiry
Slave:	40 00 2A 27 45	23 64 66 DA; header, date/time
	3D;	unit status byte
	3D 2C E2 19	00 BB 90; point 1 data
	00 00 00 00	00 BD 00; point 2 data
	00 00 00 00	00 C4 03; point 3 data
	00 00 00 00	00 8B 0A; point 4 data
	5E;	checksum

Get One Alarm - 0x47

This packet returns the oldest unread entry from the alarm history. It duplicates the functionality of packet 0x36 in a form that some masters may find more convenient. Note that this packet causes an alarm to be marked as read in the same way as packet 36. If no unread entries exist in the history, the response packet will contain zeros in the alarm date field.

Command packet to slave:

Command Code (0x47) - 1 byte

Response packet from slave:

Command Code (0x47) - 1 byte

CM4 Date - 2 bytes

CM4 Time - 2 bytes

Alarm Date - 2 bytes

Alarm Time - 2 bytes

Gas abbreviation - 6 bytes (not null terminat'd)

Point number - 1 byte

bits 0-1 point number

bits 2-7 undefined

Concentration - 4 bytes (in IEEE floating point format)

Alarm Level - 1 byte

bit 0: alarm level

0= level 1

1= level 2

bits 1-7: undefined

E.4 Configuration and Directive Commands

These are the commands and responses that the CM4 system will support for remote control and configuration.

Set K-Factor - 0x50

This command configures the manual K-Factor for a specific point. An individual point is given a K-Factor times 1000. The K-Factor is used to change the sensitivity of a point in the range of 0.200-5.000.

Command packet to instrument:

Command Code (0x50) - 1 byte

Point # - 1 byte

bit 0-1: Point to set K-Factor

00 = Point 1

01 = Point 2

10 = Point 3

11 = Point 4

bits 2-7: Undefined

K-Factor (x 1000) value - 2 bytes (200-5000)

Response packet from instrument:

Command Code (0x50) - 1 byte

CM4 Date - 2 bytes

CM4 Time - 2 bytes

Status - 1 byte

0x00 = Point configured and verified

0x01 = Factor <0.200

0x02 = Factor >5.000

0xff = Save problem, K-Factor unchanged

Reset Fault or Alarm - 0x51

This command allows a remote reset of any faults or alarm conditions.

Command packet to instrument:

Command Code (0x51) - 1 byte

Flag - 1 byte

bits 0-4: Reset selection

0x01 = Point 1 alarms

0x02 = Point 2 alarms

0x04 = Point 3 alarms

0x08 = Point 4 alarms

0x10 = Faults

Response packet from instrument:

Command Code (0x51) - 1 byte

CM4 Date - 2 bytes

CM4 Time - 2 bytes

Status - 1 byte

0x00 = Alarms reset

0xff = Error

Set Key-Code - 0x52

This command allows you to reconfigure the keypad lock-out and key code. The keypad can be disabled, preventing unauthorized user intervention by enabling the keypad lockout (bit 0). This configures the keypad and a new key code.

The old key code must match the code currently programmed into the CM4 monitor for this command to succeed in changing the code.

Command packet to instrument:

Command Code (0x51) - 1 byte

Keypad Status - 1 byte

bit 0: Keypad lock-out function

0 = Disable

1 = Enable

bits 1-7: Undefined

Old Key code - 2 bytes (valid 0000 - 9999)

New Key code - 2 bytes (valid 0000-9999)

Response packet from instrument:

Command Code (0x51) - 1 byte

CM4 Date - 2 bytes

CM4 Time - 2 bytes

Status -1 byte

0x00 = Saved and verified

0x01 = Key code invalid

0xff = Error, not saved

Lock Keyboard - 0x53

This command allows you to lock out the keyboard. The keyboard can be disabled, preventing unauthorized user intervention by enabling the keypad lock out and sending a valid key code.

This allows only persons with the key code to operate the keypad.

Command packet to instrument:

Command Code (0x53) - 1 byte

Keypad Status -1 byte

bit 0: Lock or unlock keypad

0 = Unlocked

1 = Locked

bits 1-7: Undefined

Key code - 2 bytes (valid 0000 - 9999)

Response packet from instrument:

Command Code (0x53) - 1 byte

CM4 Date - 2 bytes

CM4 Time - 2 bytes

Status -1 byte

0x00 = Saved and verified

0x01 = Key code invalid

0xff = Error, not saved

Set 2mA Fault Operation - 0x54

This command configures the unit for an output option of 2 milliamperes rather than the default 4 milliamperes.

Command packet to instrument:

Command Code (0x54) - 1 byte

Enable/Disable - 1 byte

0 = Featured disabled

1 = Feature enabled

Response packet from instrument:

Command Code (0x54) - 1 byte

CM4 Date - 2 bytes

CM4 Time -2 bytes

Status - 1 byte

0x00 = Feature programmed

0xff = Error occurred

Start New Cycle - 0x55

This command allows you to toggle the unit into and out of the Monitor mode.

Command packet to instrument:

Command Code (0x55) - 1 byte

State - 1 byte

bit 0: Take/put into analysis

0 = Take out of Monitor mode

1 = Put in Monitor or pull window

bits 1-7: Undefined

Response packet from instrument:

Command Code (0x55) - 1 byte

CM4 Date - 2 bytes

CM4 Time - 2 bytes

Status - 1 byte

0x00 = Request Executed

0xff = Error

Program Chemcassette Counter - 0x56

This command enables/disables the Chemcassette counter. When enabled, the system will provide a fault when there is approximately 24 hours of Chemcassette remaining.

Command packet to instrument:

Command Code (0x56) - 1 byte

Enable/disable -1 byte

bit 0: Enable/disable the Chemcassette counter

0 = Disable

1 = Enable

bits 1-7: Undefined

Response packet from instrument:

Command Code (0x56) - 1 byte

CM4 Date - 2 bytes

CM4 Time -2 bytes

Return Status - 1 byte

0x00 = Counter is enable/disable

0x01 = No windows left

0x02 = Maintenance status exists (Low Chemcassette)

0xff = Error in programming counter

Set Printer Configuration - 0x57

This command configures the printer for output.

Command packet to instrument:

Command Code (0x57) - 1 byte

Setup Status - 1 byte

bit 0: Printer port enable/disable

bits 1-2: Printer Report format

00 = Continuous (prints all conc. for each pt)

01 = Summary (prints alarms, faults, and TWA only)

10 = Compressed (prints conc. \geq LDL)

11 = Invalid

bits 3-5: Printer baud rate

000 = 1200

001 = 2400

010 = 4800

011 = 9600

100 = 19200

bit 6: printer hardware handshaking (flow control)

0 = Disabled

1 = Enabled

bit 7: Undefined

Response packet from instrument:

Command Code (0x57) - 1 byte

CM4 Date - 2 bytes

CM4 Time - 2 bytes

Status Flag - 1 byte

0x00 = Printer programmed

0x01 = Invalid report format

0xff = Printer programming error

Set Point Enable/Disable – 0x58

This command enables or disables points on the CM4 monitor.

Command packet to instrument:

Command Code (0x58) - 1 byte

Point enable mask - 1 byte

bits 0-3: Point selection

0x01 = Point 1 enable

0x02 = Point 2 enable

0x04 = Point 3 enable

0x08 = point 4 enable

bits 4-7: Undefined

Response packet from instrument:

Command Code (0x58) - 1 byte

CM4 Date - 2 bytes

CM4 Time - 2 bytes

Status - 1 byte

0x00 = Point enable updated and verified

0xff = Error, not saved

Set Point Configuration - 0x59

This command configures an individual point. The point can be configured even if it is disabled.

Command packet to instrument:

Command Code (0x59) - 1 byte

Point to be configured - 1 byte

bits 0-1: Point #

00 = Point 1

01 = Point 2

10 = Point 3

11 = Point 4

Gas Table # - 1 byte (0 = first table)

Alarm Level 1 - 2 bytes

Alarm Level 2 - 2 bytes

20 mA Full Scale - 2 bytes

Point ID - 20 bytes

Response packet from instrument:

Command Code (0x59) - 1 byte

CM4 Date - 2 bytes

CM4 Time - 2 bytes

Status - 1 byte

0x00 = Point configured and verified

0x01 = Gas error

0x02 = Alarm 1 Err (L1 < LAL or L1 > FS)

0x04 = Alarm 2 Error (L2 < L1 or L2 > FS)

0x08 = 20 mA Error (< LAL or > FS)

0xff = Save problem

Set TWA Time - 0x5A

This command configures the TWA time output. You need to enter only the initial TWA output time. The other two time factors are calculated automatically.

Command packet to instrument:

Command Code (0x5A) - 1 byte

TWA Time - 2 bytes

Command Code (0x5A) - 1 byte

CM4 Date - 2 bytes

CM4 Time - 2 bytes

Status - 1 byte

0x00 = Value saved and verified

0x02 = Minutes Invalid

0xff = Not saved

Set Display Time - 0x5B

This command configures the length in seconds Cycle that the concentration for each point is displayed while in the Monitor mode.

Command packet to instrument:

Command Code (0x5B) - 1 byte

Cycle time - 1 byte (valid 2-10 sec)

Response packet from instrument:

Command Code (0x5B) - 1 byte

CM4 Date - 2 bytes

CM4 Time - 2 bytes

Status - 1 byte

0x00 = Value saved and verified

0x01 = Value < 2 seconds

0x02 = Value > 10 seconds

0xff = Not saved

Set Idle Time - 0x5C

This command configures how long the unit can be left out of analysis before setting an Instrument fault. Idle time allows you to exit the Monitoring mode without causing an Instrument fault (if the idle time is > 0). You simply set the idle time to an appropriate idle (non-monitoring) time. If the idle time has expired and the unit is not in the Monitoring mode, an instrument fault will be issued. An idle time setting of 0 disables this option.

Command packet to instrument:

Command Code (0x5C) - 1 byte

Idle Time - 1 byte (0 disabled, 1-45 mins)

Response packet from instrument:

Command Code (0x5C) - 1 byte

CM4 Date - 2 bytes

CM4 Time - 2 bytes

Status - 1 byte

0x00 = Value saved and verified

0x01 = Value > 45

0xff = Not saved

Set Date Format - 0x5D

This command changes the current date format on the display and printer outputs only. It does not change the date format for communication.

Command packet to instrument:

Command Code (0x5D) - 1 byte

Format Flag - 1 byte

bit 0: Date format

0 = MM/DD/YY

1 = DD/MM/YY

Response packet from instrument:

Command Code (0x5D) - 1 byte

CM4 Date - 2 bytes

CM4 Time - 2 bytes

Status - 1 byte

0x00 = Format changed

0xff = Error

Set Date and Time - 0x5E

This command allows you to configure the unit to a new time and date. Use this feature to synchronize the time and date between the remote equipment and multiple CM4 monitors.

Command packet to instrument:

Command Code (0x5E) - 1 byte

New Date - 2 bytes

New Time - 2 bytes

Response packet from instrument:

Command Code (0x5E) - 1 byte

CM4 Date - 2 bytes

CM4 Time - 2 bytes

Status - 1 byte

0x00 = Date and time configured
and verified

0x01 = Month bad

0x02 = Day bad

0x04 = Year bad

0x10 = Hour bad

0x20 = Minutes bad

0x40 = Seconds bad

0xff = Save problem

Set Relay State - 0x5F

This command allows you to configure the relay states. The relays are normally de-energized, and can be configured to operate in the energized fail-safe condition. When the relays are latched, they are cleared by operator intervention. Non-latching relays are cleared automatically once the concentration decreases below the alarm level threshold, or the fault is corrected without operator intervention.

Command packet to instrument:

Command Code (0x5F) - 1 byte

Relay Flags - 1 byte

bit 0: Relay state

0 = De-energized

1 = Energized

bit 1: Relay latching state

0 = Non-latching

1 = Latching

bits 2-7: Undefined

Response packet from instrument:

Command Code (0x5F) - 1 byte

CM4 Date - 2 bytes

CM4 Time - 2 bytes

Status - 1 byte

0x00 = relays state set

0xff = Error, relays state not changed

End Point Lock-on - 0x60

This command unlocks the unit from a single point lock-on to all other points that are enabled. When this command is issued, a new TWA start for all points.

Command packet to instrument:

Command Code (0x60) - 1 byte

Response packet from instrument:

Command Code (0x60) - 1 byte

CM4 Date: - 2 bytes

CM4 Time - 2 bytes

Status - 1 byte

0x00 = Points unlocked

0xff = Error

Start Point Lock-on - 0x61

This command locks the unit to one specific point. When this command is issued, all other points are disabled and locked-on point continues to monitor for concentration and TWA.

Command packet to instrument:

Command Code (0x61) - 1 byte

Point Lock - 1 byte

bits 0-1: point to lock on

00 = Point 1

01 = Point 2

10 = Point 3

11 = Point 4

Response packet from instrument:

Command Code (0x61) - 1 byte

CM4 Date - 2 bytes

CM4 Time - 2 bytes

Status - 1 byte

0x00 = Point locked

0x01 = Selected point not enabled

0xff = Error

Save Current Configuration - 0x62

This command saves a backup copy of the current configuration to nonvolatile memory in the CM4 monitor. This configuration can be restored using the Restore Configuration command.

Command packet to instrument:

Command Code (0x62) - 1 byte

Response packet from instrument:

Command Code (0x62) - 1 byte

CM4 Date - 2 bytes

CM4 Time - 2 bytes

Status - 1 byte

0x00 = Configuration saved

0xff = Error

Restore Configuration - 0x63

This command restores a configuration that was previously saved to nonvolatile memory in the CM4 monitor.

Command packet to instrument:

Command Code (0x63) - 1 byte

Response packet from instrument:

Command Code (0x63) - 1 byte

CM4 Date - 2 bytes

CM4 Time - 2 bytes

Status - 1 byte

0x00 = Configuration restored

0xff = Error, configuration unchanged

Set Duty Cycle - 0x65

This command allows a master to set the minimum window time and the monitor relay response bits on a slave. Please see packet 0x69, GetDutyCycle for a discussion of these parameters.

Command packet to slave:

Command code (0x65) - 1 byte

Bits permitting monitor relay action during duty cycle - 1 byte

bit 0 point1

bit 1 point2

bit 2 point3

bit 3 point4

bits 4-7 unused (ignored by slave)

Minimum window time (seconds) - 2 bytes

Response from slave:

Command code (0x65) - byte

CM4 date 2 bytes

CM4 time 2 bytes

Status - 1 byte

0x00 packet accepted

0x01 time >900 seconds, unacceptable

0x02 time < 0 seconds, unacceptable

0xFF slave in monitor, unable to accept changes

Set Filter - 0x66

This command allows a master to set the lifetime of a filter. See packet 44 for a discussion of these parameters. The valid range of lifetimes is 30 to 365 days. The system maintains the number of days remaining as a constant if the lifetime changes.

Command packet to instrument:

- Command code (0x66) - 1 byte
- Internal filter lifetime (days) - 2 bytes
- External filter lifetimes (days) - 2 bytes

Response from instrument:

- Command code (0x66) - 1 byte
- CM4 date - 2 bytes
- CM4 time - 2 bytes
- Status - 1 byte
 - 0x00 = packet accepted
 - 0x01 = internal filter lifetime unacceptable
 - 0x02 = external filter lifetime unacceptable
 - 0xFF = slave in monitor, unable to accept changes

Get Duty Cycle - 0x69

This command allows the master to find out the minimum window time and the monitor relay action during duty cycle bits on a slave.

The minimum window time (or duty cycle) defaults to zero seconds. But it may be set larger to conserve tape in installations that have some concentration of gas for long periods of time. The tape will not advance until the minimum window time has accumulated even if the tape is saturated. During periods when the tape is saturated but prevented from advancing, the CM4 will continue to report the most recent concentration reading. Unfortunately it will not be able to detect any changes in concentration during this period because the tape is saturated.

By default, the monitor relay (RY6) will energize when monitoring is temporarily suspended because of tape saturation. However this reaction can be inhibited for individual points. The “monitor relay action during duty cycle” bits default to TRUE but can be set to FALSE via either the keypad or serial packet 0x65, Set Duty Cycle.

Command Packet to slave:

- Command code (0x69) - 1 byte

Response from slave:

- Command code (0x69) - 1 byte
- CM4 date 2 bytes
- CM4 time 2 bytes
- Bits permitting monitor relay action during Duty cycle - 1 byte
 - bit 0 point1
 - bit 1 point2
 - bit 2 point3
 - bit 3 point4
 - bits 4-7 unused (always 0)
- Min window time (seconds) - 2 byte
- Status - 1 byte (always 0x00)

E.5 Operation

E.5.1 CM4 Instrument Power-up

Upon power-up, the CM4 instrument conducts a self-diagnostic procedure to check its memory, hardware, and voltages. After the self-diagnostics, the instrument automatically begins monitoring, and the COM port (if enabled) is activated.

E.5.2 Commands

Your CM4 instrument will accept and process commands sent to it from your equipment.

E.5.3 Responses

The CM4 instrument will send a return communication for any message it receives at its address. Included in most response packets from the CM4 instrument are date and time stamps.

E.6 Example Packets

The following section contains examples of packets from a master to a slave and the slave's responses. Protocol version 2 is used. The address of the slave is 1. All numbers are in hexadecimal.

Master	40 01 00 06 28 91
Slave	40 00 01 06 20 99

Master	40 01 00 06 31 88
Slave	40 00 01 20 31 24 A6 47 31 5E C1 02 00 00 00 00 00 FF FF FF FF 00 B9 00 A5 00 A4 00 CD 00 00 40

Master	40 01 00 06 35 84
Slave	40 00 01 30 35 24 A6 47 33 01 4E 48 33 2D 49 49 00 81 00 FA 01 F4 02 EE 02 EE 50 54 31 2D 43 4D 34 2D 38 35 31 2D 30 30 30 36 20 20 20 20 00 39

Master	40 01 00 06 37 82
Slave	40 00 01 21 37 24 A6 47 35 4E 48 33 2D 49 49 81 00 B9 24 A6 47 10 24 A6 47 35 00 00 00 00 00 00 F8

Master	40 01 00 06 3C 7D
Slave	40 00 01 1B 3C 24 A6 47 39 4E 48 33 2D 49 49 02 EE 00 FA 00 1E 00 1E 81 04 00 EB

Master	40 01 00 06 3D 7C
Slave	40 00 01 1D 3D 24 A6 47 3A 03 24 A6 46 E2 09 81 24 A6 46 CF 09 81 24 A5 81 17 09 81 47

Master	40 01 00 06 45 74
Slave	40 00 01 27 45 24 A6 47 45 09 00 00 00 00 00 BA
	00 00 00 00 00 00 A6 00 00 00 00 00 00 00 A3 00 00
	00 00 00 00 CC 00 25
Master	40 01 00 09 50 00 03 E8 7B
Slave	40 00 01 0B 50 24 A6 47 6A 00 E9

Master	40 01 00 07 51 1F 48
Slave	40 00 01 0B 51 24 A6 47 50 00 02

Master	40 01 00 07 55 00 63
Slave	40 00 01 0B 55 24 A6 47 60 00 EE

Master	40 01 00 22 59 00 00 00 FA 01 F4 02 EE 50 4F 49
	4E 54 5F 49 44 5F 53 54 52 49 4E 47 5F 00 00 00
	00 5A
Slave	40 00 01 0B 59 24 A6 48 30 00 19

The following section contains examples of packets from a master to a slave and the slave's responses. Protocol version 1 is used.

Master	40 01 05 28 92
Slave	40 00 05 20 9B

Master	40 01 05 30 8A
Slave	40 00 14 30 22 A6 43 C8 00 06 02 05 FF FF 37 AB 71
	A5 00 A6

Master	40 01 05 31 89
Slave	40 00 1F 31 22 A6 43 CB 5E CA FF FF 0C 1C 00 20 00
	2A 00 2A 00 00 00 00 00 00 00 00 00 00 1F 00 B9

Master	40 01 05 32 88
Slave	40 00 0B 32 22 A6 43 FA 2D 00 51
Master	40 01 05 33 87
Slave	40 00 0A 33 22 A6 43 E9 00 8F

Master	40 01 05 34 86
Slave	40 00 22 34 22 A6 43 D8 22 A5 6A 7B 22 A5 6A 7D 22
	A6 41 78 22 A6 41 89 22 A6 41 4E 22 A6 22 A6 00 33
Master	40 01 06 35 00 84
Slave	40 00 2F 35 22 A6 43 FD 01 4E 48 33 2D 49 49 00 81
	00 FA 01 F4 02 EE 02 EE 50 54 31 2D 43 4D 34 2D 38
	35 31 2D
	30 30 30 36 20 20 20 20 00 77

Master	40 01 05 36 84
Slave	40 00 64 36 22 A6 43 E0 06 22 A5 6A E8 4E 48 33 2D
	49 49 03 81 02 EE 01 22 A5 6A CA 4E 48 33 2D 49 49
	03 81 02
	EE 01 22 A5 6A 06 4E 48 33 2D 49 49 02 81 02 EE 01
	22 A5 6A
	06 4E 48 33 2D 49 49 01 81 02 EE 01 22 A5 69 F2 4E
48 33 2D	
	49 49 02 81 02 EE 01 22 A5 69 F2 4E 48 33 2D 49 49
	01 81 02
	EE 01 87

Master	40 01 06 37 00 82
Slave	40 00 20 37 22 A6 43 E5 4E 48 33 2D 49 49 81 00 00
	22 A6 00 F9 22 A6 41 06 00 00 00 00 00 00 A0

Master	40 01 05 38 82
Slave	40 00 10 38 22 A6 44 03 00 00 40 00 80 00 00 A9

Master	40 01 05 39 81
Slave	40 00 0B 39 22 A6 44 06 04 00 66

Master	40 01 05 3B 7F
Slave	40 00 0A 3B 22 A6 44 09 1D 49

Master	40 01 05 3D 7D
Slave	40 00 22 3D 22 A6 43 ED 04 22 A5 6A 9D 1B 02 22 A5 69 DD 05 01 22 A5 69 BC 05 01 22 A5 69 B1 05 01 8E

Master	40 01 05 3E 7C
Slave	40 00 12 3E 22 A6 44 0C 03 E8 03 E8 03 E8 03 E8 00 AC

Master	40 01 05 43 77
Slave	40 00 0E 43 22 A6 43 F1 01 F4 01 90 00 ED

Master	40 01 05 44 76
Slave	40 00 0E 44 22 A6 43 F4 00 2A 00 2A 00 1B

Master	40 01 08 50 00 04 57 0C
Slave	40 00 0A 50 22 A6 44 85 00 D5

Master	40 01 06 51 1F 49
Slave	40 00 0A 51 22 A6 44 17 00 42

Master	40 01 0A 52 01 04 57 00 00 07
Slave	40 00 0A 52 22 A6 44 8E 00 CA

Master	40 01 08 53 00 04 57 09
Slave	40 00 0A 53 22 A6 44 20 00 37

Master	40 01 06 54 01 64
Slave	40 00 0A 54 22 A6 44 93 00 C3
Master	40 01 06 55 01 63
Slave	40 00 0A 55 22 A6 44 25 00 30

Master	40 01 06 56 01 62
Slave	40 00 0A 56 22 A6 44 97 00 BD

Master	40 01 06 57 1B 47
Slave	40 00 0A 57 22 A6 44 A1 00 B2

Master	40 01 06 58 0D 54
Slave	40 00 0A 58 22 A6 44 A7 00 AB

Master	40 01 07 5A 09 60 F5
Slave	40 00 0A 5A 22 A6 44 AD 00 A3
Master	40 01 06 5B 02 5C
Slave	40 00 0A 5B 22 A6 44 B1 00 9E

Master	40 01 06 5C 2C 31
Slave	40 00 0A 5C 22 A6 44 B8 00 96

Master	40 01 06 5D 00 5C
Slave	40 00 0A 5D 22 A6 44 BC 00 91

Master	40 01 09 5E 22 A6 44 67 E5
Slave	40 00 0A 5E 22 A6 44 35 00 17

Master	40 01 06 5F 02 58
Slave	40 00 0A 5F 22 A6 44 C4 00 87

Master	40 01 05 60 5A
Slave	40 00 0A 60 22 A6 44 76 00 D4

Master	40 01 06 61 00 58
Slave	40 00 0A 61 22 A6 44 72 00 D7

Master	40 01 08 65 0F 00 64 DF
Slave	40 00 0A 65 22 A6 44 CB 00 7A

Master	40 01 05 69 51
Slave	40 00 0D 69 22 A6 44 11 0F 00 00 00 1E

E.7 Serial Device Applications

The serial interface is designed for unidirectional communication from a CM4 monitor to a single printer or other remote device. It is possible, therefore, that the application for this interface requires connection to a remote device other than the printer options described in this appendix.



CAUTION

Cabling used between the CM4 monitor and the external device must be shielded and properly grounded to maintain reliable operation and control RF emissions and susceptibility

For these applications, note the pin-out configuration in each of the diagrams.

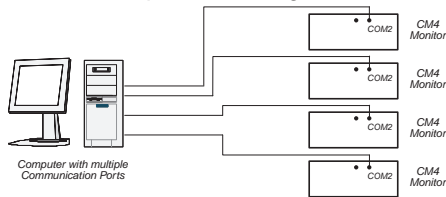

Multiple CM4 monitors and a single computer

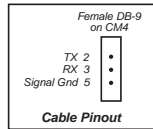

Interface	RS-232 P/N 874022-R Rear Panel Mount
Jumpers	See Section D.2 for DCE settings
Computer Port	Customer-supplied RS-232C; check user device for compatibility before ordering.
Cable	User-supplied. Refer to diagram for pin-out configuration. Also, refer to the EMC Considerations section on page D-2 .
Protocol	Customer-written per information in Appendix E.
Note	Maximum range: 50 Ft.

Figure E-1: Serial Interface, Multiple CM4s, Single Computer, Unidirectional Communications

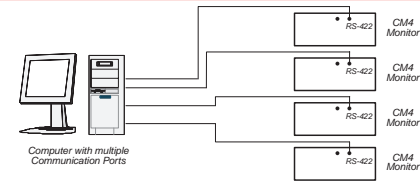

**Multiple CM4 monitors and a single computer
Bi-Directional Communication up to 4000 ft distance**

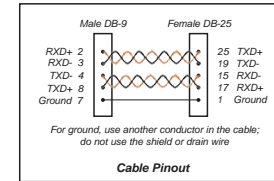

Interface	RS-232 P/N 874024-R Rear Panel Mount
Computer Port	Customer-supplied; check user device for compatibility before ordering.
Cable	User-supplied. Refer to diagram for pin-out configuration. Also, refer to the EMC Considerations section on page D-2 .
Protocol	Customer-written per information in Appendix E.
Note	Maximum range: 4000 Ft.

Figure E-2: Bidirectional Communication, Single Computer, Multiple CM4s up to 4000 ft distance.

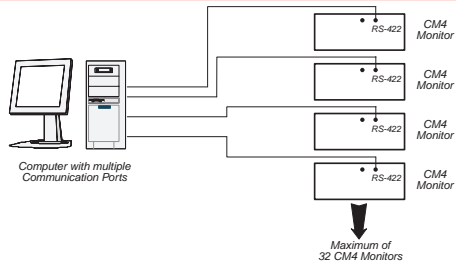

**Multiple CM4 monitors and a single computer
Bi-Directional Communication over a 2-wire system**

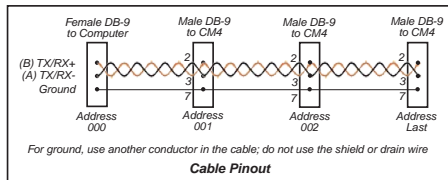

Interface	RS-232 P/N 874327-R Rear Panel Mount
Computer Port	Customer-supplied; check user device for compatibility before ordering.
Cable	User-supplied. Refer to diagram for pinout configuration. Drop distance between the CM4 and the daisy-chain cable should be as short as possible (less than three feet). Refer to EMC Considerations section on page D-2 .
Protocol	Customer-written per information in Appendix E.
Note	Refer to the computer port documentation for specific pinout information for the computer's RS485 interface. RS485 ports are limited to 32 nodes due to drive-level limitations. The number of nodes per port can be extended up to 255 by use of RS485 repeaters.

Figure E-3: Bidirectional Communication, Single Computer, Multiple CM4s over a two-wire system.

E.7.1 Impedance Matching

The communication interfaces in the first and last units in the daisy-chain configuration **must have matching impedance**. This is true whether the computer is at the end of the daisy chain or within the daisy chain. Check the computer's interface to determine the impedance termination resistor's value and how to install/set. The illustrations below show two daisy chain schemes, the first with the computer on the end of the daisy chain, and the second with the computer within the daisy chain. The impedance termination resistors on all interfaces between the first and last units are removed.

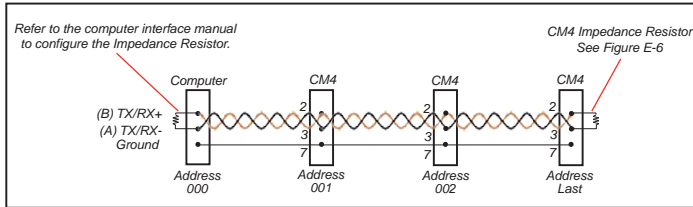

Figure E-4: Configuration showing Computer at one end of a Daisy-Chain

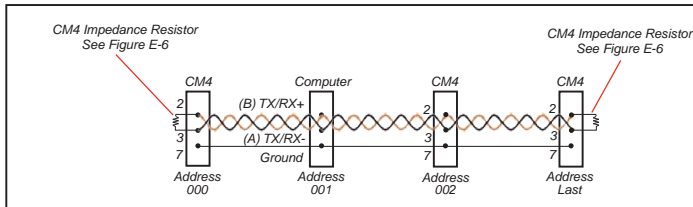

Figure E-5: Configuration showing Computer in the middle of a Daisy-Chain

The CM4 unit's impedance termination resistor is located on the RS-485 interface as shown below. The resistor plugs into sockets on the interface board for easy removal or insertion; there is no soldering required.

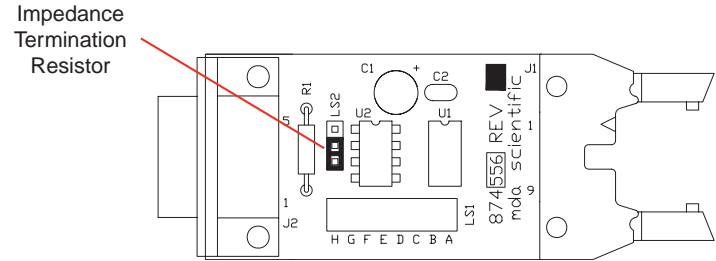

Figure E-6: CM4 RS-485 Interface Board Impedance Resistor Location.

E.8 Glossary

The following terms are used in this manual:

Byte: A byte is a collection of 8 bits (or pieces) of information used in the communication process. A byte refers to these 8 bits as a single entity. Each bit has a value of either 0 or 1.

Communication: The act or process of passing digital information between two points.

Data: Information that is transferred between the equipment and the CM4 monitor. Data refers to the information contained within a packet (see Packet). This information may be gas concentration, date, or other information.

Equipment: This term is used to refer to the master device which is used to communicate with the CM4 monitor(s). The equipment can be a personal computer (PC) or other device capable of performing the digital communications described in this protocol.

Handshake: The process of acknowledging a communication has been received. The CM4 monitor uses ACK/NAK responses.

Hexadecimal: A type of numbering system with a base of 16. In this numerical system, numbers 10 through 15 are represented by the letters A through F respectively. The shortened version of the word hexadecimal is generally “Hex,” as in “Hex 42.” “0x” is the notation used in this manual for hexadecimal (e.g. 0x42).

Instrument: This term is used to refer to the CM4 four-point continuous monitor.

Master: Another computer which communicates with slaves using the CM4 protocol.

Packet: A block of information that is passed between the instrument and the equipment. A packet is made from many bytes of information.

Protocol: The manner in which data is transferred and the format used for the transfer. CM4 protocol refers to the packets of transferred data the CM4 instrument recognizes.

Slave: The MDA Scientific CM4 gas monitor. A network may have several slaves.

Time-Out: The maximum amount of time allowed between the time the last byte of a packet is sent from the “master” device to the time the “slave” device responds. The time-out period for this protocol is one second.

F Installation Drawing

CM4 Four-Point Continuous Monitor

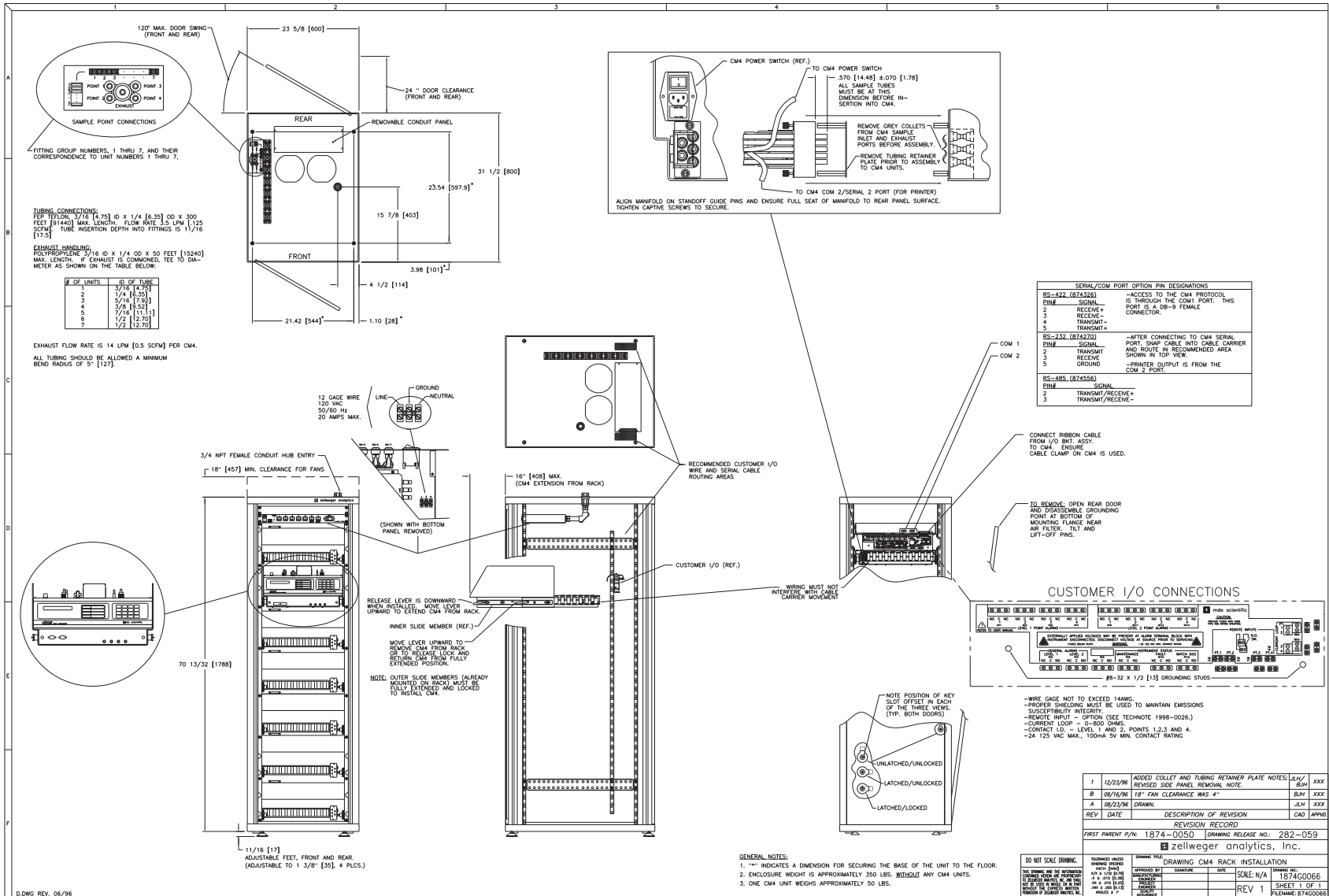

G Warranty Statement

Chemcassette® Device Warranty Statement

All products are designed and manufactured to the latest internationally recognized standards by Honeywell Analytics under a Quality Management System that is certified to ISO 9001.

As such, this instrument (including the pump) is warranted under proper use, to the original end-user purchaser, against any defects in materials or workmanship related failures for a period of 12 months from the date of first turn-on or 18 months from delivery from Honeywell Analytics to the customer, whichever is less. Separate warranty conditions apply to the sensor cartridges limited as indicated below. During this period, Honeywell Analytics will repair or replace defective parts on an exchange basis, F.O.B. to approved service centers on a global basis.

This warranty does not cover damage caused by accident, abuse, abnormal operating conditions or extreme poisoning of the sensor cartridge.

Defective equipment must be returned to Honeywell Analytics for repair. Before returning materials for repair or replacement, the Customer must obtain a Service Event Number (SE#) by contacting Honeywell Analytics Service in advance; include a detailed report stating the nature of the defect and ship the equipment prepaid to Honeywell Analytics' factory. If no detail report is included, Honeywell Analytics reserves the right to charge an investigative fee (prices available upon request) before any repair or replacement is performed. Returned goods must detail the Service Event Number (SE#) clearly on the package.

Service in the field or at the customer's premises is not covered under these warranty terms. Time and travel expenses for on-site warranty services will be charged at Honeywell Analytics' normal billing rates. Contact your Honeywell Analytics representative for information on available Service Contracts.

Honeywell Analytics shall not be liable for any loss or damage whatsoever or howsoever occasioned which may be a direct or indirect

result of the use or operation of the Contract Goods by the Buyer or any Party.

This warranty covers the gas detector and parts sold to the Buyer only by authorized distributors, dealers and representatives as appointed by Honeywell Analytics. This warranty does not cover defects attributable to improper installation, repair by an unauthorized person or the use of unauthorized accessories/parts on the product. A warranty claim will only be accepted if a proof of purchase is submitted and all conditions obtained within this Warranty are met.

Honeywell Analytics reserves the right to validate any warranty claim prior to processing. Upon acceptance of a warranty claim, Honeywell Analytics will repair or replace the defective product free of charge. The initial warranty period is not extended by virtue of any works carried out there after.

Instruments which have been repaired or replaced during the warranty period are warranted for the remainder of the unexpired portion of the original warranty period. Honeywell Analytics is released from all obligations under its warranty in the event repairs or modifications are made by persons other than its own authorized personnel, unless such work is authorized in writing by Honeywell Analytics. Honeywell Analytics is released from all obligations under its warranty in the event that detection substrates other than Honeywell Analytics' Chemcassettes® have been installed and used in Honeywell Analytics' instruments.

Honeywell Analytics reserves the right to change this policy at any time. Contact Honeywell Analytics for the most current warranty information.

Chemcassette® Warranties

All Chemcassettes® are warranted for a period not to exceed the Chemcassette® expiration date printed on each package, and tape reel.

Find out more

www.honeywellanalytics.com

Americas

Honeywell Analytics
405 Barclay Boulevard
Lincolnshire, IL 60069
Tel: +1 847 955 8200
Toll free: +1 800 538 0363
Fax: +1 847 955 8208
detectgas@honeywell.com

Europe, Middle East, and Africa

Life Safety Distribution AG
Wilstrasse 11-U11
CH-8610 Uster
Switzerland
Tel: +41 (0)1 943 4300
Fax: +41 (0)1 943 4398
gasdetection@honeywell.com

Technical Services

ha.global.service@honeywell.com

www.honeywell.com

Asia Pacific

Honeywell Analytics
#508, Kolon Science Valley (I)
187-10 Guro-Dong, Guro-Gu
Seoul, 152-050 Korea
Tel: +82 2 2025 0300
Fax: +82 2 2025 0329
analytics.ap@honeywell.com

Please Note:

While every effort has been made to ensure accuracy in this publication, no responsibility can be accepted for errors or omissions.

Data may change, as well as legislation, and you are strongly advised to obtain copies of the most recently issued regulations, standards and guidelines.

This publication is not intended to form the basis of a contract.

Honeywell

971305 Rev 9

February 2008

© 2008 Honeywell Analytics