

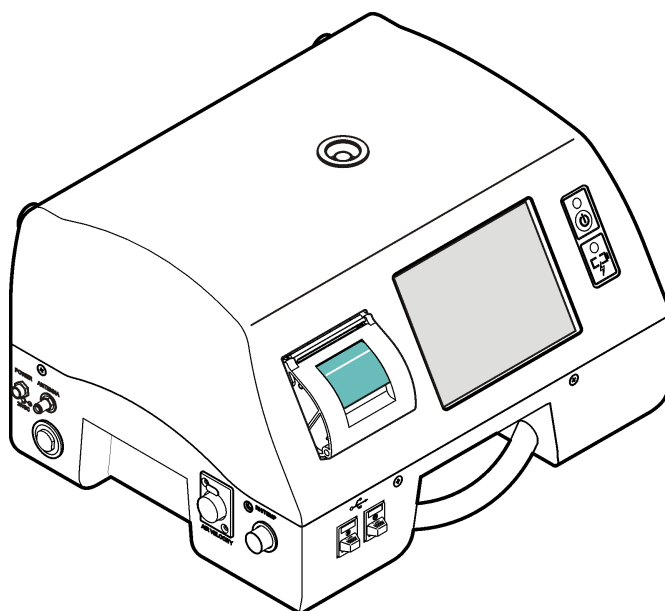

 **Instruction For Use**

MET ONE 3400: 3413, 3415, 3423, 3425, 3445

Air Particle Counter



CE

DOC026.53.80202, Edition 7
12/2017



Beckman Coulter, Inc.
250 S. Kraemer Blvd.
Brea, CA 92821 U.S.A.

 **BECKMAN
COULTER**

MET ONE 3400: 3413, 3415, 3423, 3425, 3445

DOC026.53.80202, Edition 7 (12/2017)

© 2017 Beckman Coulter, Inc.

All rights reserved.

Beckman Coulter, the stylized logo, and the Beckman Coulter product and service marks mentioned herein are trademarks or registered trademarks of Beckman Coulter, Inc. in the United States and other countries.

All other trademarks, service marks, products, or services are trademarks or registered trademarks of their respective holders.

Contact Us

If you have any questions, contact our Customer Support Center.

- Worldwide, find us via our website at www.beckmancoulter.com/customersupport/support.
- In the USA and Canada, call us at 1-800-369-0333.
- Outside of the USA and Canada, contact your local Beckman Coulter Representative.

Original Instructions

Revision History

Edition 7, 12/2017

Software Version 4.09.XX

Updates were made to the following sections:

Safety Notice

RoHS Notice

CHAPTER 2, General Information

Precautionary Labels

Compliance

CHAPTER 3, Installation

Connect RS485 Communication (Optional)

Electrical connections

CHAPTER 5, Particle Counter Navigation

Icons – General

CHAPTER 6, Configuration

About Basic and Advanced Operation

Store Partial Data

Assign User Access Rights

CHAPTER 7, Operation

Use the Filter Scan Probe

About Standard Sampling Protocols

Start Sample Measurement with the Wizard

Use Existing Data

Set the Data Filter

About Status Values in Exported Data

Configure and Enable the FTP Function

CHAPTER 8, Maintenance

Calibrate the Battery

CHAPTER 10, Parts and Accessories

Parts for the 28.3 LPM Counter (3413 and 3415)

Parts for the 50 LPM Counter (3423 and 3425)

Parts for the 100 LPM Counter (3445)

3400 Series Parts

This document applies to the latest software listed and higher versions. When a subsequent software version affects the information in this document, a new issue will be released to the Beckman Coulter Web site. For labeling updates, go to www.beckmancoulter.com and download the latest version of the manual or system help for your instrument.

Safety Notice

Read all product manuals and consult with Beckman Coulter-trained personnel before attempting to operate instrument. Do not attempt to perform any procedure before carefully reading all instructions. Always follow product labeling and manufacturer's recommendations. If in doubt as to how to proceed in any situation, contact your Beckman Coulter Representative.

Alerts for Danger, Warning, Caution, Important, and Note

DANGER

DANGER indicates an imminently hazardous situation which, if not avoided, will result in death or serious injury.

WARNING

WARNING indicates a potentially hazardous situation which, if not avoided, could result in death or serious injury. May be used to indicate the possibility of erroneous data that could result in an incorrect diagnosis.

CAUTION

CAUTION indicates a potentially hazardous situation, which, if not avoided, may result in minor or moderate injury. It may also be used to alert against unsafe practices. May be used to indicate the possibility of erroneous data that could result in an incorrect diagnosis.

IMPORTANT **IMPORTANT** is used for comments that add value to the step or procedure being performed. Following the advice in the Important adds benefit to the performance of a piece of equipment or to a process.

NOTE **NOTE** is used to call attention to notable information that should be followed during installation, use, or servicing of this equipment.

 **WARNING**

Risk of operator injury if:

- All doors, covers, and panels are not closed and secured in place prior to and during instrument operation.
- The integrity of safety interlocks and sensors is compromised.
- Instrument alarms and error messages are not acknowledged and acted upon.
- You contact moving parts.
- You mishandle broken parts.
- Doors, covers, and panels are not opened, closed, removed, and/or replaced with care.
- Improper tools are used for troubleshooting.

To avoid injury:

- Keep doors, covers, and panels closed and secured in place while the instrument is in use.
- Take full advantage of the safety features of the instrument. Do not defeat safety interlocks and sensors.
- Acknowledge and act upon instrument alarms and error messages.
- Keep away from moving parts.
- Report any broken parts to your Beckman Coulter Representative.
- Open/remove and close/replace doors, covers, and panels with care.
- Use the proper tools when troubleshooting.

 **CAUTION**

System integrity could be compromised and operational failures could occur if:

- This equipment is used in a manner other than specified. Operate the instrument as instructed in the Product Manuals.
- You introduce software that is not authorized by Beckman Coulter into your computer. Only operate your system's computer with software authorized by Beckman Coulter.
- You install software that is not an original copyrighted version. Only use software that is an original copyrighted version to prevent virus contamination.

 **CAUTION**

If you purchased this product from anyone other than Beckman Coulter or an authorized Beckman Coulter distributor, and, it is not presently under a Beckman Coulter service maintenance agreement, Beckman Coulter cannot guarantee that the product is fitted with the most current mandatory engineering revisions or that you will receive the most current information bulletins concerning the

product. If you purchased this product from a third party and would like further information concerning this topic, contact your Beckman Coulter Representative.

Disposal of Electronic Equipment

It is important to understand and follow all laws regarding the safe and proper disposal of electrical instrumentation.



The symbol of a crossed-out wheeled bin on the product is required in accordance with the Waste Electrical and Electronic Equipment (WEEE) Directive of the European Union. The presence of this marking on the product indicates:

- That the device was put on the European Market after August 13, 2005 and
- That the device is not to be disposed via the municipal waste collection system of any member state of the European Union.

For products under the requirement of WEEE directive, please contact your dealer or local Beckman Coulter office for the proper decontamination information and take back program which will facilitate the proper collection, treatment, recovery, recycling, and safe disposal of device.

RoHS Notice

These labels and materials declaration table (the Table of Hazardous Substance's Name and Concentration) are to meet People's Republic of China Electronic Industry Standard SJ/T11364-2006 "Marking for Control of Pollution Caused by Electronic Information Products" requirements.

RoHS Caution Label



This label indicates that the electronic information product contains certain toxic or hazardous substances. The center number is the Environmentally Friendly Use Period (EFUP) date, and indicates the number of calendar years the product can be in operation. Upon the expiration of the EFUP, the product must be immediately recycled. The circling arrows indicate the product is recyclable. The date code on the label or product indicates the date of manufacture.

RoHS Environmental Label



This label indicates that the electronic information product does not contain any toxic or hazardous substances. The center 'e' indicates the product is environmentally safe and does not have an Environmentally Friendly Use Period (EFUP) date. Therefore, it can safely be used indefinitely. The circling arrows indicate the product is recyclable. The date code on the label or product indicates the date of manufacture.

Contents

	Revision History, iii
	Safety Notice, v
CHAPTER 1:	Specifications, 1-1
	Instrument Specifications, 1-1
	Sample Measurement Specifications, 1-2
	Battery Specifications, 1-2
CHAPTER 2:	General Information, 2-1
	Safety Information, 2-1
	Use of Hazard Information, 2-1
	Precautionary Labels, 2-2
	Compliance, 2-2
	Country-specific Approval for Wi-Fi Devices, 2-3
	Certification, 2-4
	General Product Information, 2-4
CHAPTER 3:	Installation, 3-1
	Product components, 3-1
	Wiring safety information, 3-2
	Electrostatic discharge (ESD) considerations, 3-2
	Electrical connections, 3-2
	Install the Batteries, 3-4
	Assemble the Particle Counter System, 3-5
	Install the Printer Paper, 3-5
	Connect RS485 Communication (Optional), 3-7
CHAPTER 4:	Network and Communications, 4-1
	About Network and Communications Setup, 4-1
	Setup for Serial Communication, 4-1
	Setup for Ethernet Communication, 4-2
	Setup for Wireless Communication, 4-2
	Set Wireless Security, 4-3

CHAPTER 5: Particle Counter Navigation, 5-1

CHAPTER 6: Configuration, 6-1

About Configuration, 6-1

About Basic and Advanced Operation, 6-1

Set the Operation Mode at Initial Startup, 6-1

Change the Operation Mode, 6-2

Configure the System, 6-2

Set the Time and Date, 6-2

Set the Sleep Mode and Backlight Timeout, 6-3

Set the Alarm Reasons Option, 6-3

Set the Sample Comments Option, 6-4

Set the User Interface Language, 6-5

Manage Units and Alarms, 6-5

Manage Audible Alarm Settings, 6-5

Set the Measurement Units, 6-6

Set the Flow Rate Alarm Values, 6-6

Add an Alarm Reason, 6-7

Edit an Alarm Reason, 6-7

Delete an Alarm Reason, 6-8

Apply an Alarm Reason to a Data Record, 6-8

Set the Inert Gas and Altitude Values, 6-9

Set the Particle Count Alert (Beep Function), 6-9

Change the Relative Humidity and Temperature Probe, 6-10

Manage Backup and Restore Settings, 6-10

Make a Backup of Configurable Settings, 6-10

Restore Settings from Backup, 6-10

Configurations, 6-11

Copy a Configuration, 6-11

Install a Configuration, 6-11

Locations, Areas and Groups, 6-12

Location Management, 6-12

Add a Location, 6-12

Edit a Location, 6-13

Configure New Settings for the Location, 6-13

Copy Settings from Another Location, 6-14

Set Location Alarms, 6-14

Remove a Location, 6-15

Change the Order of Locations, 6-15

Area Management, 6-16

Add a New Area, 6-16

Edit an Area, 6-16

Remove an Area, 6-16

Change the Order of Areas, 6-17

Group Management, 6-17

Add a Group, 6-17

Install a Group, 6-18

- Delete a Group, 6-18
 - Add a Location to a Group, 6-18
- Sizes Function, 6-19
- Data Management, 6-19
 - Store Partial Data, 6-19
 - Manage the Data Buffer, 6-20
 - Set the Data Buffer to Rotate Data, 6-20
 - Set the Data Buffer Size, 6-20
- Real-time PDF/CSV Option, 6-21
 - Turn on the PDF Option, 6-21
 - Save the Count Data to a Folder, 6-21
- Manage Users and Permissions, 6-22
 - Enable the User Logon Function, 6-22
 - Log on as Administrator, 6-22
 - Change the Password, 6-23
 - Replace a Forgotten Password, 6-23
 - Add a User, 6-24
 - Assign Groups to a User, 6-24
 - Assign User Access Rights, 6-25

CHAPTER 7: Operation, 7-1

- Log on to the Particle Counter, 7-1
- Measure Particle Counts, 7-1
 - Change the Particle Count Location, 7-2
 - See Settings During the Particle Count, 7-2
 - See Historical Data During the Particle Count, 7-2
 - Use the Filter Scan Probe, 7-2
 - Manage Sample Batch Identification, 7-3
 - Enter or Change a Batch ID, 7-3
 - Disable a Batch ID, 7-3
 - Set or Clear the Batch ID, 7-4
- How to Use the Test and Report Wizard, 7-4
 - About Standard Sampling Protocols, 7-4
 - About Reports, 7-5
 - Set up the Test and Report Wizard, 7-5
 - Start Sample Measurement with the Wizard, 7-6
 - Use Existing Data, 7-6
 - Report Test Results, 7-6
- How to Use the Print Center, 7-7
 - About the Print Center, 7-7
 - Print Records Manually, 7-7
 - Set Automatic Print Functions, 7-8
- Review Historical Buffer Data, 7-9
 - Set the Data Filter, 7-9
 - Clear the Data Buffer, 7-10

- Export Data, 7-10
 - About Status Values in Exported Data, 7-11
 - Configure and Enable the FTP Function, 7-12
- Data Transfer to the OPC Server, 7-13
 - User-initiated Data Upload, 7-13
 - User-initiated Data Download, 7-13
 - Automatic Data Download, 7-14

CHAPTER 8: Maintenance, 8-1

- Clean the Instrument Exterior, 8-1
- Set the Count to Zero, 8-1
- Update the Instrument Software, 8-2
- Charge the Batteries in the Particle Counter, 8-3
 - Battery Recharge Intervals, 8-3
- Calibrate the Battery, 8-4

CHAPTER 9: Diagnostics and Troubleshooting, 9-1

- Factory Settings, 9-1

CHAPTER 10: Parts and Accessories, 10-1

- Parts for the 28.3 LPM Counter (3413 and 3415), 10-1
- Parts for the 50 LPM Counter (3423 and 3425), 10-1
- Parts for the 100 LPM Counter (3445), 10-1
- 3400 Series Parts, 10-2
- Spare Parts Kit (2087919-01), 10-3

Related Documents

Illustrations

- 3.1 Instrument components, 3-1
- 3.2 Back View, 3-3
- 3.3 Front and Side View, 3-3
- 3.4 Particle Counter Assembly, 3-5
- 3.5 Printer Paper Installation, 3-6
- 7.1 Averages report, 7-8
- 7.2 Buffer report (all buffer records), 7-8

Tables

2.1	MET ONE 3400 Series Particle Counter Model Numbers, 2-4
5.1	Icons - Counter Navigation Screen, 5-1
5.2	Icons - General, 5-2
6.1	Alarm Reasons Options, 6-4
7.1	Sample Status Bit Mask Definitions, 7-11
8.1	Battery LED Color Indications, 8-3
8.2	Suggested Battery Recharge Interval, 8-3
9.1	System Diagnostics Screen Example - Clock Battery Failure, 9-1

CHAPTER 1

Specifications

Specifications are subject to change without notice.

Instrument Specifications

Specification	Detail
Power requirement	Adapter (included in the ship kit): 100–240 VAC, 2.5 A, 50–60 Hz
	Instrument: 24 VDC, 75 W maximum
Installation category	I
Protection class	III
Pollution degree	2
Altitude	2000 m (6562 ft)
Light source	Long Life Laser™ diode with 10-year Mean Time To Failure (MTTF), Class 3B Laser, 810 to 852 nm, 50 mW maximum
Pump type	Air vacuum, rated for continuous use
Count display	Color ¼ VGA TFT touch screen
Interface	Windows CE®-based
Maximum count shown	9,999,999
Delay time	00:00:06 to 23:59:59
Sample and hold times	Sample: 00:00:01 to 23:59:59
	Hold: 00:00:00 to 23:59:59
Count alarms	1 to 9,999,999 counts
Data storage	50 to 5000 samples, scrollable on Historical Data review screen 3000 is the default value
Count cycles	Up to 100 while in automatic mode
Locations	Up to 999
Exhaust port	3/8-in. NPT thread
Outputs	Ethernet–10Base-T/100Base-TX
	RS485 Serial
	RS232 Serial
	Optional wireless–802.11 b/g compatible
	USB Client (Version 1.1)
	USB Host (Version 1.1)
Manifold	Supports A3432, 32-port manifold system (available on 1 CFM units only)

Specification	Detail
Enclosure material	Stainless steel
Weight without battery	3413 and 3415—7.55 kg (16.6 lb)
	3423 and 3425—8.33 kg (18.3 lb)
	3445—8.65 kg (19.0 lb)
Size (W x D x H)	31.8 x 25.4 x 20.3 cm (12.5 x 10 x 8 in.)
Environment, operation	0 to 40 °C (32 to 104 °F); 10 to 90% relative humidity, non-condensing
Environment, storage	-40 to 50 °C (-40 to 122 °F); 0 to 98% relative humidity, non-condensing

Sample Measurement Specifications

Sampling	
Number of size ranges	Standard 6, 8
Particle size ranges and standard channels	Models 3413 and 3423—0.3, 0.5, 1.0, 3.0, 5.0, 10.0 µm
	Models 3415 and 3425—0.5, 1.0, 2.0, 3.0, 5.0 and 10.0 or 25.0 µm
	Models 3445—0.5, 1.0, 2.0, 3.0, 5.0, 10.0 µm
Flow rate	Models 3413 and 3415—28.3 L/min (1.00 cfm) ± 5% (Default factory setting)
	Models 3423 and 3425—50 L/min (1.77 cfm) ± 5% (Default factory setting)
	Model 3445—100 L/min (3.53 cfm) ± 5% (Default factory setting)
Zero count	Conforms to JIS B9921. 1 count or less in 5 minutes, 95% confidence level
Coincidence loss	Models 3413 and 3415—10% at 20,000,000 particles/m ³ (566,570 particles/ft ³)
	Models 3423 and 3425—10% at 10,000,000 particles/m ³ (283,280 particles/ft ³)
	Model 3445—10% at 5,000,000 particles/m ³ (141,640 particles/ft ³)
Count efficiency	Models 3413 and 3423—50% ± 20% for 0.3 µm, (100% ± 10% at 1.5 times the minimum sensitivity). Fully complies with ISO21501-4.
	Models 3415, 3425 and 3445—50% ± 20% for 0.5 µm, (100% ± 10% at 1.5 times the minimum sensitivity). Fully complies with ISO21501-4.

Battery Specifications

Specification	Detail
Battery type	Lithium ion smart battery; can be charged, ejected and changed without disruption to the system.
Quantity included	One (two batteries are provided with the 3445)

Specification	Detail
Battery life during operation	Models 3413 and 3415—6 hours Models 3423 and 3425—7 hours Model 3445—3.5 hours
Battery life during operation	3 hours minimum ^a
Battery recharge time	6.75 hours minimum, 10 hours maximum
Power	14.4 VDC, 6.6 Ah (2x)
Battery weight	0.66 kg (1.45 lb)

- a. With two fully-charged batteries in a 1.0 CFM unit sampling for 20 minutes (1 m³ sample), print record, a 5-minute hold time (simulating a move to new location), then repeating this cycle. The backlight time-out set to 2 minutes.

In no event will the manufacturer be liable for direct, indirect, special, incidental or consequential damages resulting from any defect or omission in this manual. The manufacturer reserves the right to make changes in this manual and the products it describes at any time, without notice or obligation. Revised editions are found on the manufacturer's website.

Safety Information

IMPORTANT The manufacturer is not responsible for any damages due to misapplication or misuse of this product including, without limitation, direct, incidental and consequential damages, and disclaims such damages to the full extent permitted under applicable law. The user is solely responsible to identify critical application risks and install appropriate mechanisms to protect processes during a possible equipment malfunction.

Please read this entire manual before unpacking, setting up or operating this equipment. Pay attention to all danger and caution statements. Failure to do so could result in serious injury to the operator or damage to the equipment.

Make sure that the protection provided by this equipment is not impaired. Do not use or install this equipment in any manner other than that specified in this manual.

Use of Hazard Information



Indicates a potentially or imminently hazardous situation which, if not avoided, will result in death or serious injury.



Indicates a potentially or imminently hazardous situation which, if not avoided, could result in death or serious injury.









Indicates a potentially hazardous situation that may result in minor or moderate injury.

IMPORTANT Indicates a situation which, if not avoided, may cause damage to the instrument. Information that requires special emphasis.

Precautionary Labels

Read all labels and tags attached to the instrument. Personal injury or damage to the instrument could occur if not observed. A symbol on the instrument is referenced in the manual with a precautionary statement.

	This symbol, if noted on the instrument, references the instruction manual for operation and/or safety information.
	This symbol, when noted on a product enclosure or barrier, indicates that a risk of electrical shock and/or electrocution exists.
	Delicate internal electronic components can be damaged by static electricity, resulting in degraded performance or eventual failure.
	This symbol indicates a laser device is used in the equipment.
	This symbol identifies the location of a fuse or current limiting device.
	Electrical equipment marked with this symbol may not be disposed of in European public disposal systems after 12 August of 2005. In conformity with European local and national regulations (EU Directive 2002/96/EC), European electrical equipment users must now return old or end-of-life equipment to the Producer for disposal at no charge to the user. NOTE For return for recycling, please contact the equipment producer or supplier for instructions on how to return end-of-life equipment, producer-supplied electrical accessories, and all auxiliary items for proper disposal.
	A "CE" mark indicates that a product has been assessed before being placed on the market, and has been found to meet European Union safety, health, and/or environmental protection requirements.

Compliance

	This symbol indicates that the instrument is a Class 1 LASER product.
---	---

This product complies with IEC/EN 60825-1 and 21 CFR 1040.10 except for deviations pursuant to Laser Notice No. 50, dated June 24, 2007. FDA accession number: 9020917.

This product is also CE compliant. Contact the manufacturer for complete compliance details.

Country-specific Approval for Wi-Fi Devices



Electromagnetic radiation hazard. Make sure that the antenna is kept at a minimum distance of 20 cm (7.9 in.) from all personnel in normal use. The antenna cannot be co-located or operated in conjunction with any other antenna or transmitters.

Products with the wireless option contain a modular RF Wi-Fi device that operates in the 2.4 GHz range.

- United States FCC ID: R68WIPORTG
- Canada IC ID: 3867A-WIPORTG

Country	ISO31662 letter code	Country	ISO31662 letter code
Austria	AT	Poland	PL
Belgium	BA	Portugal	PT
Denmark	DK	Spain	ES
Finland	FI	Sweden	SE
France	FR	United Kingdom	GB
Germany	DE	Iceland	IS
Greece	GR	Norway	NO
Hungary	HU	Switzerland	CH
Ireland	IE	Turkey	TR
Italy	IT	Netherlands	NL
Mexico	MX		

Regulatory RF Device Approvals

- FCC: Approved as a Modular Device under a TCB Grant of Authorization. FCC ID: R68WIPORTG
- IC: Approved as a Modular Device under Certificat D'Acceptabilite' Technique C-REL ID : 3867A-WIPORTG

Opinion: Compliant under the R&TTE Directive 1999/5/EC to the essentials requirements of Article 3.2 according to the assessment procedures in Article 10(5) and Annex IV for (class-2 equipment) and marked as CE1177.

Certification

The device complies with Part 15 of the FCC Rules and Industry Canada license-exempt RSS standard(s). Operation is subject to the following conditions:

1. The equipment may not cause harmful interference.
2. The equipment must accept any interference received, including interference that may cause undesired operation.

Changes or modifications to this wireless communication equipment not expressly approved by the party responsible for compliance could void the user's authority to operate the equipment. Any change to the equipment will void the Industry Canada certification and FCC grant.

General Product Information

This manual describes the use of the MET ONE 3400 Series Particle Counter. The MET ONE 3400 Series Particle Counter counts and measures the size of airborne particles in cleanroom environments. Refer to [Table 2.1](#).

Table 2.1 MET ONE 3400 Series Particle Counter Model Numbers

Model number	Flow rate		Minimum particle size channel (µm)
	L/min	Ft ³ /min	
3413	28.3	1	0.3
3415	28.3	1	0.5
3423	50	1.77	0.3
3425	50	1.77	0.5
3445	100	3.53	0.5

! WARNING

! Multiple hazards. Only qualified personnel must conduct the tasks described in this section of the document.

Product components

Remove all items from the shipping container and inspect for damage. If any items are missing or damaged, contact the manufacturer. Refer to [Figure 3.1](#).

Figure 3.1 Instrument components

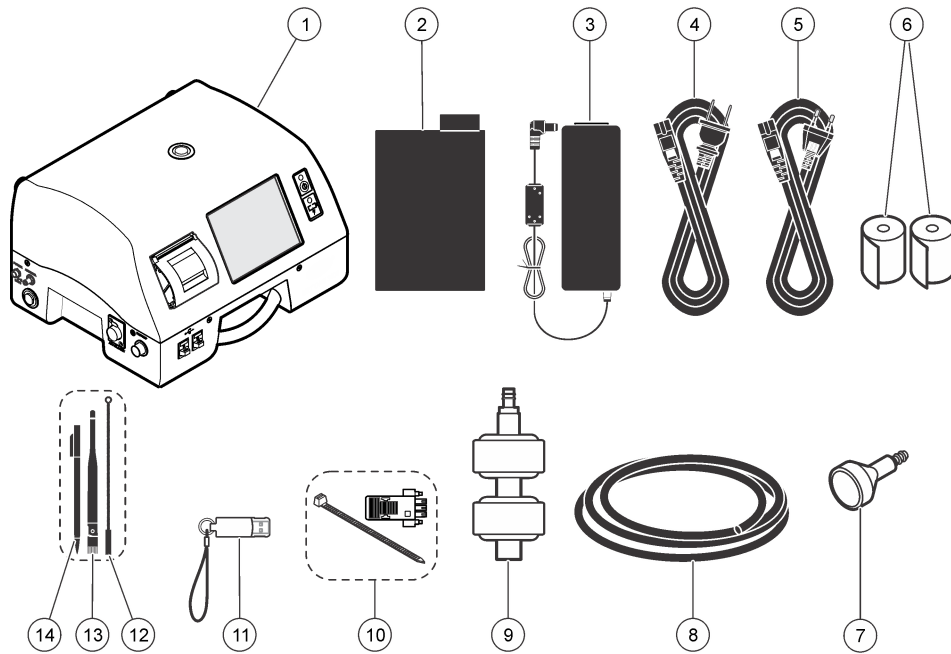

- | | |
|---|--|
| 1. 3400 Series Particle Counter | 8. Extension tube for isokinetic probe |
| 2. Rechargeable battery (280-120-2024) | 9. Zero count filter |
| 3. AC-to-DC power supply (280-300-5000) | 10. RS485 connector assembly |
| 4. Power cord (US) | 11. USB Flash drive |
| 5. Power cord (EU) | 12. Intake cleaning brush |
| 6. Thermal paper rolls for printer (2x) | 13. Wireless antenna for Wi-Fi |
| 7. Isokinetic probe | 14. Stylus for touchscreen interface |

Wiring safety information



Electrocution hazard. Make sure that there is easy access to the local power disconnect.

IMPORTANT Always disconnect power to the instrument before electrical connections are made.

Obey all safety statements while connections are made to the instrument.

Electrostatic discharge (ESD) considerations



IMPORTANT Potential Instrument Damage. Delicate internal electronic components can be damaged by static electricity, resulting in degraded performance or eventual failure.

Refer to the steps in this procedure to prevent ESD damage to the instrument:

- Touch an earth-grounded metal surface such as the chassis of an instrument, a metal conduit or pipe to discharge static electricity from the body.
- Avoid excessive movement. Transport static-sensitive components in anti-static containers or packages.
- Wear a wrist strap connected by a wire to earth ground.
- Work in a static-safe area with anti-static floor pads and work bench pads.

Electrical connections

Connect probes, external power, cables and USB devices as shown in [Figure 3.2](#) and [Figure 3.3](#).

Figure 3.2 Back View

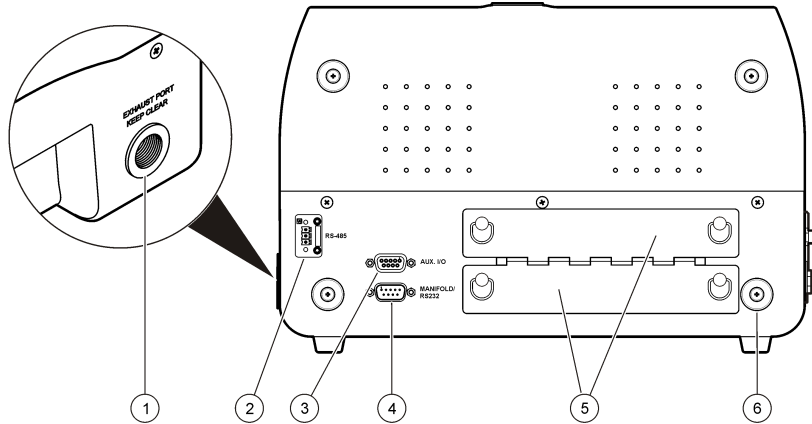

- | | |
|---|--|
| 1. Exhaust port | 4. Manifold controller connector or standard RS232 port
(available on 1 CFM units only) |
| 2. Serial communications RS485 connector | 5. Battery ports |
| 3. Auxiliary I/O port for the filter scan probe | 6. Supplemental feet |

Figure 3.3 Front and Side View

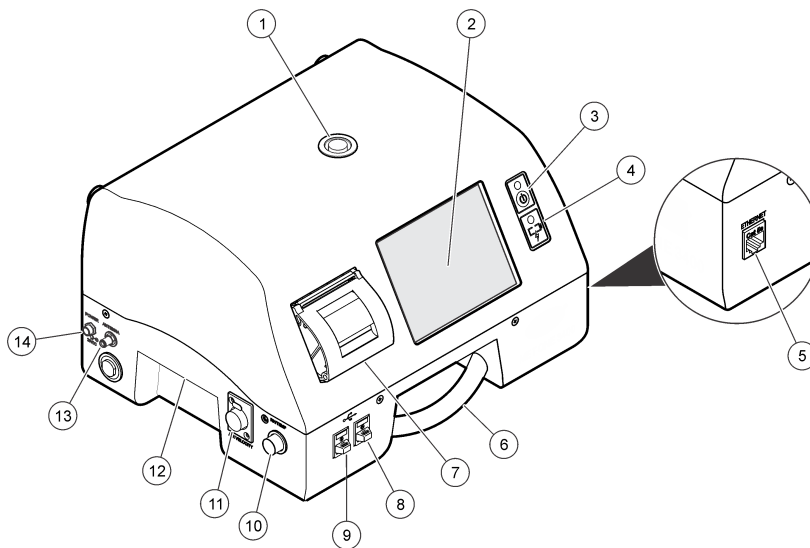

- | | |
|-----------------------------|---|
| 1. Sample intake nozzle | 8. USB host connector |
| 2. Touchscreen | 9. USB client connector |
| 3. Power button | 10. Relative humidity and temperature probe connector |
| 4. Battery status indicator | 11. Air velocity probe connector |
| 5. Ethernet connector | 12. Handle |
| 6. Handle | 13. Wireless antenna connector |
| 7. Printer | 14. Power connector |

NOTE For best results, use USB flash drives supplied by the manufacturer. [Contact Us](#) for additional support.

Install the Batteries



Explosion hazard. To avoid fire and/or explosion, use only the battery type and power supply/charger specified by the manufacturer. For part numbers, refer to [Figure 3.1](#).

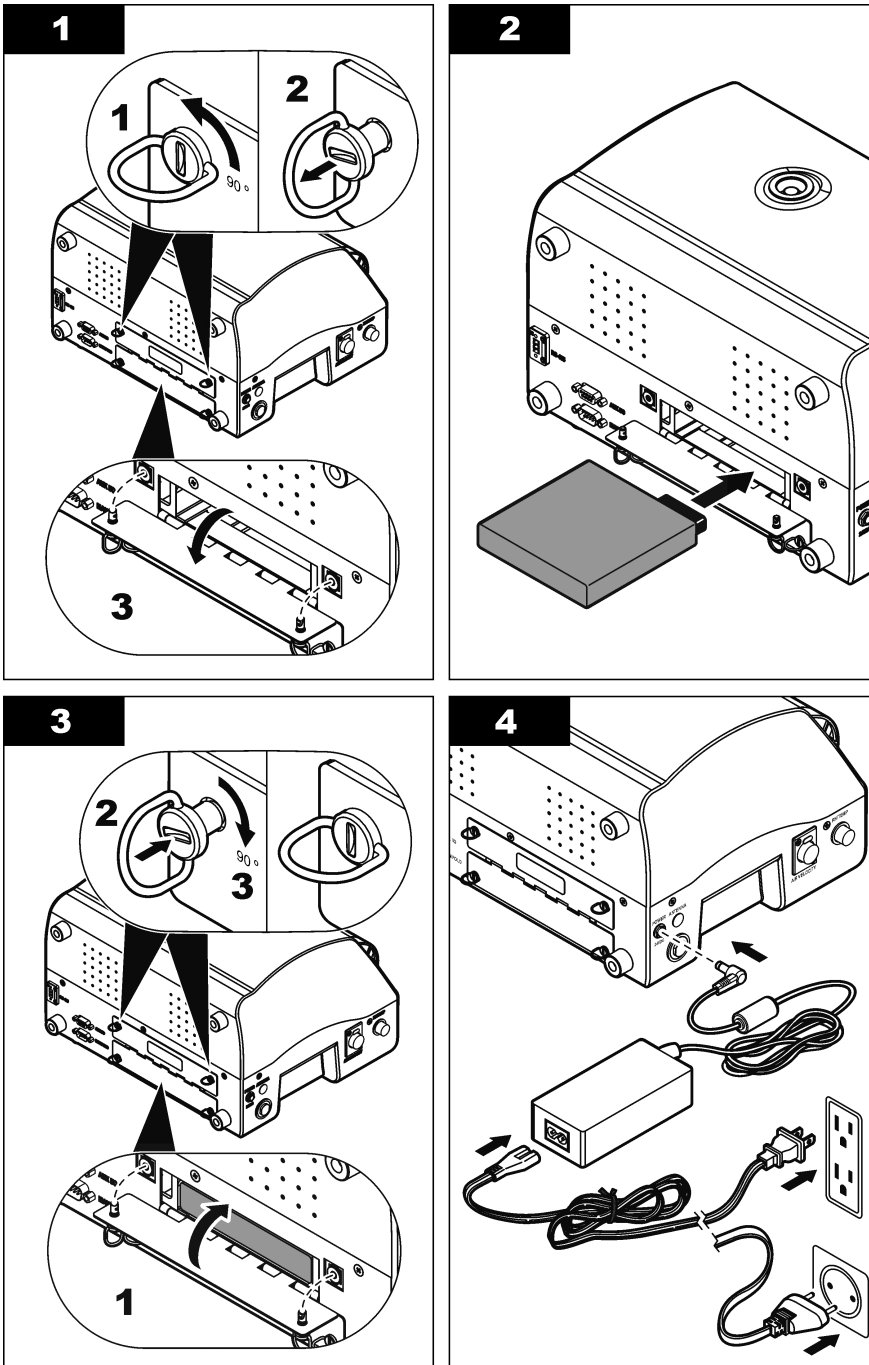

Assemble the Particle Counter System

Figure 3.4 shows the setup of the particle counter system.

Figure 3.4 Particle Counter Assembly

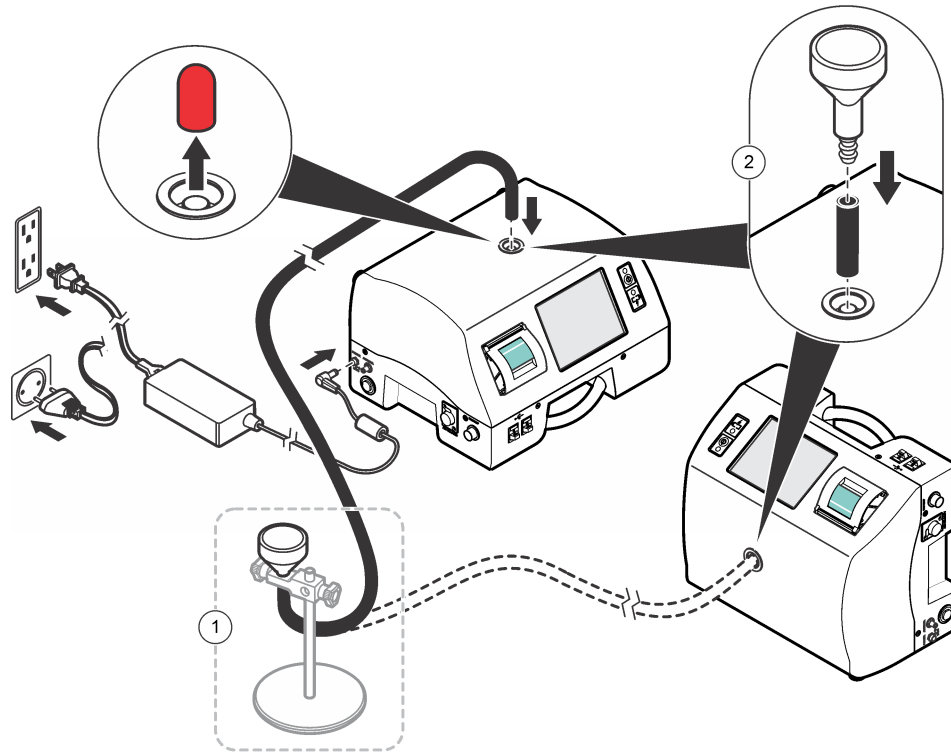

1. Remote installation of the probe^a
 2. Local installation of the probe
- a. Shown with the optional isokinetic probe stand. Refer to [3400 Series Parts](#) for ordering information.

Install the Printer Paper

IMPORTANT To avoid damage to the printer, do not operate the printer without paper. Use only the recommended thermal paper. If the particle counter must be used without paper, be sure to set the print mode to "None".

Refer to the illustrated steps in [Figure 3.5](#) to install printer paper.

Figure 3.5 Printer Paper Installation

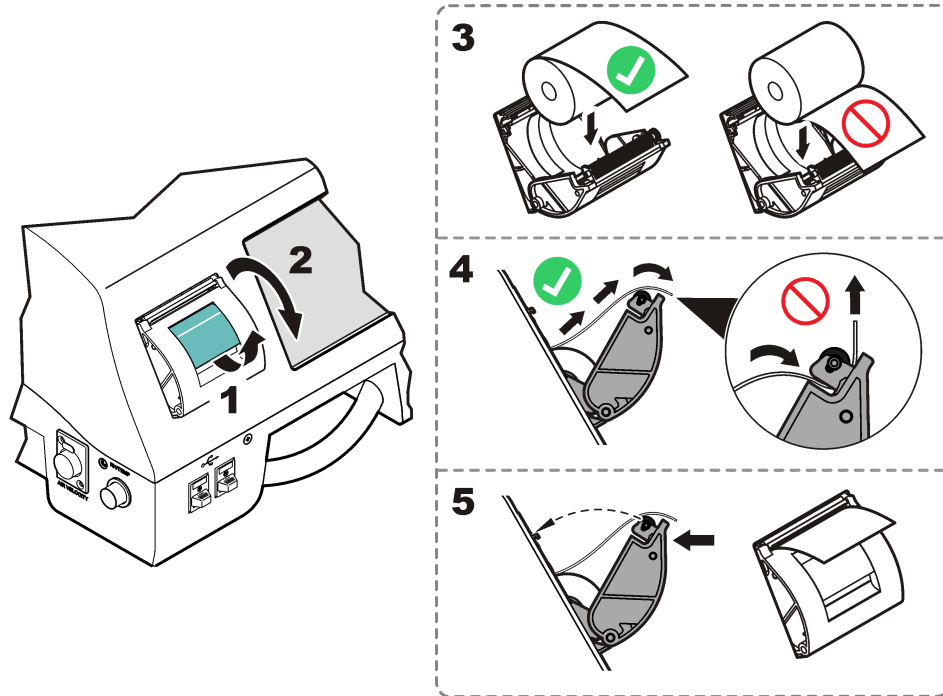

Connect RS485 Communication (Optional)

To connect for RS485 communication, refer to the illustrated steps that follow.

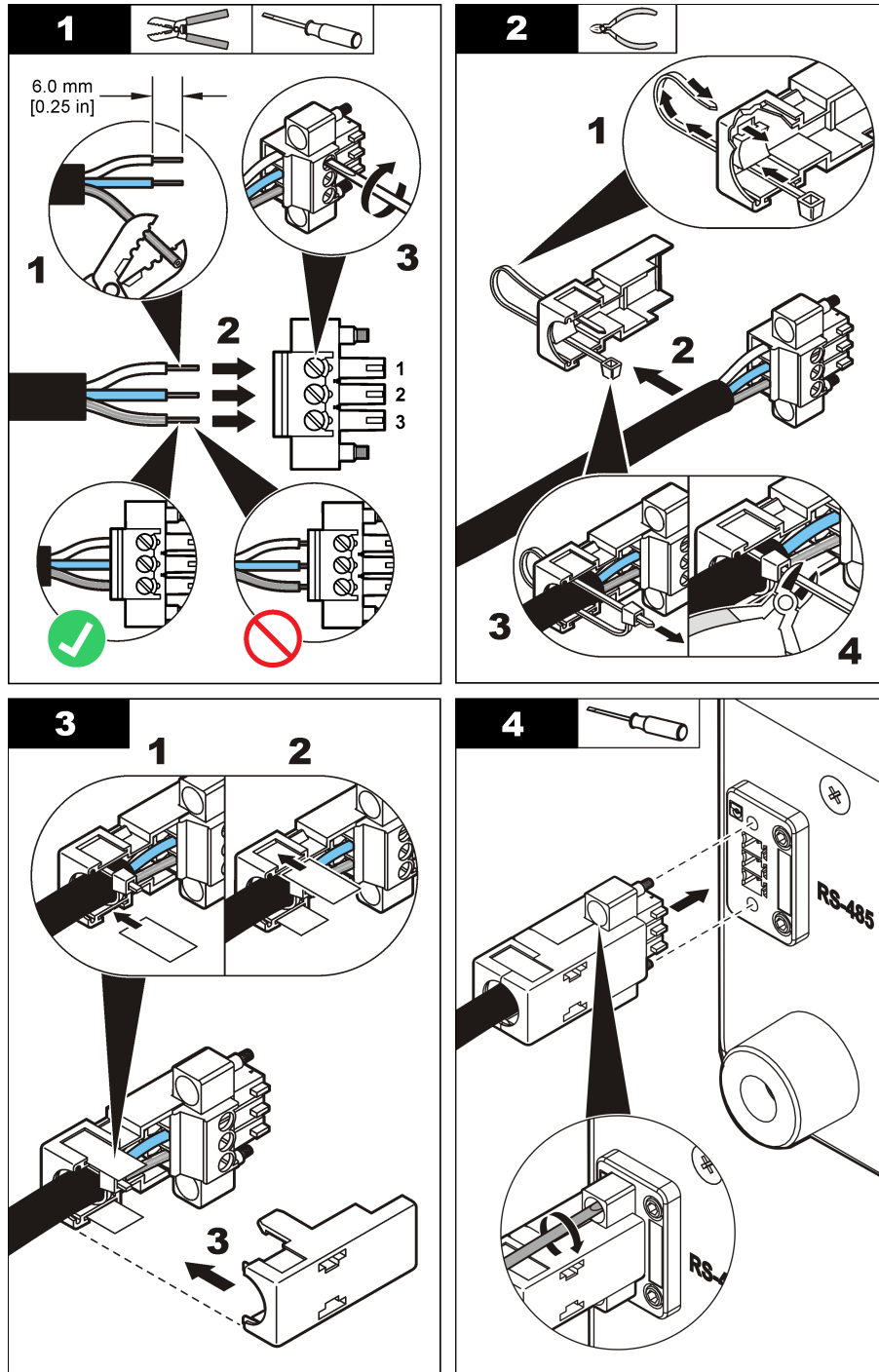

- 1. RS-485 A
- 2. RS-485 B
- 3. Ground

Installation

Connect RS485 Communication (Optional)

Network and Communications

IMPORTANT Only qualified personnel should perform the tasks described in this section.

About Network and Communications Setup



This section shows the setup for:

- Serial communications
- Ethernet network communication
- Wireless (Wi-Fi) communication
- Wireless security

Setup for Serial Communication

IMPORTANT RS232 communication and manifold support cannot be used together because they use the same serial port.

- 1** On the Counter Navigation screen, push **NETWORK**.
- 2** Select the Serial tab.
- 3** Configure these options:
 - Select FX or Modbus RTU.
 - Set the ID for FX or Modbus.
 - Set the Baud rate.
 - Select RS232 or RS485.
 - Activate Manifold Support as needed (RS485 only).
 - Activate Auto Increment Port as needed.

Setup for Ethernet Communication

- 1 On the Counter Navigation screen, push **NETWORK**.

 - 2 Select the Ethernet tab.

 - 3 Configure these options:
 - Select FX or Modbus protocol.
 - Enter the Modbus port number.
 - Enter the Configuration port number.
 - Enter the IP address or select DHCP to let the network assign the IP address.
 - Enter the subnet mask address.
 - Enter the gateway address.
-

Setup for Wireless Communication

- 1 On the Counter Navigation screen, push **NETWORK**.

 - 2 Select the Wi-Fi Configuration tab.

 - 3 Configure these options:
 - Enter the Network name.
 - Select the data rate.
 - Select the network type: Ad hoc or infrastructure.
 - Enable auto fallback as needed.
 - Select the channel (Ad Hoc mode only).
 - Check Enable Radio if needed.
 - Select the country.
-

Set Wireless Security

- 1 On the Counter Navigation screen, push **NETWORK**.

 - 2 Select the Wi-Fi Security tab.

 - 3 Configure these options:
 - Select the security type.
 - Select the encryption type.
 - Select the authentication type.
 - Select the key type: Hex or Passphrase.
 - Enter the key in the Key field and in the Retype Key field.
-

Particle Counter Navigation

The functions of the particle counter are accessed from the Counter Navigation screen. [Table 5.1](#) shows the functions that are accessible through the navigation screen.

[Table 5.2](#) shows the functions of the other icons.

Table 5.1 Icons - Counter Navigation Screen

























Icon	Function	Description
	Sample	Measure particle counts. Refer to Measure Particle Counts .
	Historical	Review measurement results in the buffer; print, export or filter data. Refer to Review Historical Buffer Data .
	Export	Output file as PDF, comma separated value (CSV), tab separated, XML or PortAll files. Refer to Export Data .
	Printer	Print sample data as hard-copy. Refer to How to Use the Print Center .
	Test wizard	Test and report wizard for ISO, EU-GMP, FS or BS classification compliance. Refer to Set up the Test and Report Wizard .
	Locations	Add/edit/remove areas; copy location settings, edit locations settings; edit alarms for specific locations. Refer to Location Management .
	Group	Load/add/edit a group; delete a group. Refer to Group Management .
	System	Time/Date; Sleep time/backlight timeout; set logon requirements; set sounds for alarms; manage users; set the units for flow rates; manage the data buffer. Refer to Configure the System .
	Sizes	Add/edit/delete a size (optional). Refer to Sizes Function .
	Diagnostics	View diagnostic information for troubleshooting. Refer to Diagnostics and Troubleshooting .
	Network	Configure the network and communication settings. Refer to About Network and Communications Setup .
	Factory	View the factory information including the calibration date. Refer to Factory Settings .

Table 5.2 Icons – General

Icon	Function	Description
	Logout	Log out the current user
	Go back	Go to the previous screen
	Run	Start sampling
	Stop	Stop sampling
	Copy the location settings	Makes a copy of the location settings
	Paste the location settings	Saves the copied location settings over the currently selected location
	Help	Show help information
	Laser	For service use only
	Printer settings	Configure the printer settings
	Alarms	Configure the alarm settings for individual locations or groups
	Filter	Start the filter probe test or configure the historical data filter settings
	Settings	Configure the sample settings for groups
	Upload	Send data to the attached PC

About Configuration

This section describes tasks that are usually done at the initial commissioning stage. Other tasks are done as updates to the particle counter are needed.

NOTE If user passwords are set, the user must be logged in as an administrator to configure the particle counter.

About Basic and Advanced Operation

At startup, the user can set the operation mode to Basic or Advanced settings.

Use the Basic mode to:

- Do all particle measurement functions
- Save run data in the buffer

Use the Advanced mode to:

- Export data
- Measure air velocity
- Set analog alarms
- Set standards wizards and reports
- Backup, restore and restart
- Copy a configuration
- Set the network protocol (serial, Ethernet, Wi-Fi)
- Manage areas and locations
- Manage user counts and security
- Set user-configurable particle sizes
- Filter data

Set the Operation Mode at Initial Startup

To set the operation mode:

-
- 1 Power on the instrument.

-
- 2 While the operation mode selection screen shows, do one of the actions that follow:
 - Select **BASIC** or **ADVANCED**.
 - Wait 10 seconds. The instrument will start in the selected operation mode.
-

Change the Operation Mode

Only permissions in the Advance Operation mode allow a user to change the operation mode. To change operation mode from Advanced to Basic mode:

-
- 1 On the Counter Navigation screen, push **SYSTEM**.
-
- 2 Select the **Custom** tab.
-
- 3 Select **BASIC MODE**.
-
- 4 Push **RETURN** to restart the instrument.
-

Configure the System



System settings control how data is measured and stored, user permissions and other system-wide parameters. System settings can be configured as part of instrument commissioning, or changed later for different applications.

Set the Time and Date

Time and date will need to be set at initial commissioning.

-
- 1 On the Counter Navigation screen, push **SYSTEM**.
-
- 2 Select the **Basic** tab.
-
- 3 Select the Time field. Use the numeric keypad to enter the current time in the HH:MM:SS format, then confirm.

-
- 4 Select the Date field. Use the numeric keypad to enter the current date in the YYYY-MM-DD format, then confirm.
-

Set the Sleep Mode and Backlight Timeout

Sleep mode and backlight time are active during battery use. When the instrument is connected to AC power, sleep mode and backlight are not active.

During sleep mode the instrument goes into hibernation after a period of inactivity to conserve power. All subsystems are shut down. The time value for sleep mode is in minutes.

The backlight setting turns off the LCD backlight after a period of inactivity to conserve power. The time value for the backlight setting is in seconds.

-
- 1 On the Counter Navigation screen, push **SYSTEM**.
-
- 2 Select the **Basic** tab.
-
- 3 Select the Sleep Time field. Enter the length of idle time before sleep mode begins, then confirm. The range is 1 to 30 minutes.
NOTE Enter **0** to disable sleep mode.
-
- 4 On the **Basic** tab, select the Backlight Timeout field. Enter the length of idle time before the user interface backlight turns off, then confirm. The range is 5 to 300 seconds.
-

NOTE Enter a value of less than 5 seconds to disable backlight timeout.

To bring the instrument out of backlight timeout, use a finger or a stylus to make the user interface touchscreen active.

Set the Alarm Reasons Option

To capture data about why alarms occur, the Alarm Reason option is set as Required or Optional. In both Required and Optional mode, the user is prompted to select from preset alarm reasons for the alarm event. All users can enter alarm reasons. Only administrators, factory-level users or users with System Settings permissions can disable or change the Alarm Reasons option.

To enable or disable Alarm reasons:

-
- 1 On the Counter Navigation screen, push **SYSTEM**.

2 On the **Units and Alarms** tab, push .

3 On the Alarm Reasons screen, select **REQUIRED**, **OPTIONAL** or **DISABLED**. Refer to [Table 6.1](#) for more information.

NOTE The Alarm Reasons option is set to Disabled by default.

Table 6.1 Alarm Reasons Options

Option	Description
Required	After doing a user-initiated sample cycle, the user is required to enter information about all alarms that happen during the cycle. Alarm reasons must be defined in the Alarm Reasons screen. The user cannot exit the Alarm History screen until a reason has been entered for all alarms.
Optional	After doing a user-initiated sample cycle, the user is prompted to enter information about all alarms that happen during the cycle. Alarm reasons must be defined in the Alarm Reasons screen.
Disabled	The user is not prompted to enter information about alarms.

Set the Sample Comments Option

To record user comments made during routine sampling, change the Sample Comments setting. Only administrators, factory-level users or users with System Settings permissions can change the Sample Comments setting.

1 On the Counter Navigation screen, push **SYSTEM**.

2 Select **Sample Comments**.

3 Select an option in the field at the bottom of the screen.

Option	Description
Required	After each user-initiated sample cycle, the user must select one of the preset sample comments from the sample comment list or enter a new comment.
Required on Alarm	After each user-initiated sample cycle, the user must select one of the preset sample comments from the sample comment list or enter a new comment if an alarm(s) occurred during the sample cycle.

Option	Description
Optional	After each user-initiated sample cycle, the user is asked if they would like to enter a comment for the sample. The user can then select one of the preset sample comments from the sample comment list or enter a new comment.
Disabled (default)	The user is not asked if they would like to enter a comment for the sample after each user-initiated sample cycle.

- 4 To add comments to the comment list so they can be quickly selected:
 - a. Select **Add**.
 - b. Use the keypad to enter a comment about a sample run.
 - c. Push **Enter**.

Set the User Interface Language

The user interface language can be changed at any time. A language change will require a system restart.

- 1 On the Counter Navigation screen, push **SYSTEM**.
- 2 Select the **Options and Accessories** tab.
- 3 Select the Language field to show language options.
- 4 Select a language. Push  then **OK** to restart the instrument.

Manage Units and Alarms

Units and alarms are controlled on the **Units and Alarms** tab. Units are set for temperature, air velocity, relative humidity and flow rate. The high and low parameter for the flow rate alarm are also enabled and set in this screen. The instrument can be set to work with the Vaisala HMP probe. Preset alarm reasons are accessible from this screen.

Manage Audible Alarm Settings

The **Sounds** tab lets the user select the sound and volume to confirm user interface actions. Sounds that are used for other alarms (stop errors, limit alarms and warnings) are selected in this tab.

-
- 1 On the Counter Navigation Screen, push **SYSTEM**.

 - 2 Select the **Sounds** tab.

 - 3 Select the User Feedback field.

 - 4 Select a sound from the list of available notification sounds.

 - 5 Select sounds for stop error, alarm limit and warnings from the list of available notification sounds.

 - 6 Use the slider to set the volume.
-

Set the Measurement Units

-
- 1 On the Counter Navigation screen, push **SYSTEM**.

 - 2 Select the **Units and Alarms** tab.

 - 3 Select the Temperature field. Select **DEG C** (Celsius) or **DEG F** (Fahrenheit).

 - 4 Select the Air Velocity Field. Select **MM/SEC** or **FT/MIN**.

 - 5 Select the Flow Rate field. Select **LPM** or **CPM**.
-

Set the Flow Rate Alarm Values

Contact technical support before the flow rate alarm is changed.

-
- 1 On the Counter Navigation screen, push **SYSTEM**.

 - 2 Select the **Units and Alarms** tab.

-
- 3 Select **ENABLED**.

 - 4 Select the High field. Enter a value between 5 and 20.

 - 5 Select the Low field. Enter a value between 5 and 20.

Add an Alarm Reason

Alarm Reasons describe what conditions have caused an alarm. If a needed Alarm Reason is not available in the list, it can be added and then applied to future data records.

-
- 1 On the Counter Navigation screen, push **SYSTEM**.

 - 2 Select the **Units and Alarms** tab.

 - 3 Push .

 - 4 Push **ADD**. Enter a reason (up to 29 characters).

 - 5 Push **ENTER** to confirm.

Edit an Alarm Reason

-
- 1 On the Counter Navigation screen, push **SYSTEM**.

 - 2 Select the **Units and Alarms** tab.

 - 3 Push .

 - 4 Select a reason from the list.

 - 5 Push **EDIT**. Change the text string as needed.

6 Push **ENTER** to confirm.

Delete an Alarm Reason

1 On the Counter Navigation screen, push **SYSTEM**.

2 Select the **Units and Alarms** tab.

3 Push .

4 Select a reason from the list.

5 Push **REMOVE**.

6 Push **ENTER** to confirm.

Apply an Alarm Reason to a Data Record

Prerequisites:

- Alarm reasons must be set to **ENABLED** or **OPTIONAL**. Refer to [Set the Alarm Reasons Option](#) for more information.
- Alarm reasons must be entered in the alarm reasons list before they can be applied to a data record. Refer to [Add an Alarm Reason](#) for more information.

An alarm reason can be applied to any data record that has an alarm. Alarm reasons show in the Historical data screen and on printouts. Alarm reasons are also included in FTP transfers and all USB flash drive exports.

1 On the Counter Navigation screen, push **HISTORICAL**.

2 Select the Data Buffer field. Enter the number of the record with the alarm, or go to the record with + and - keys.

-
- 3 Select the yellow text below Counts to show the Alarm Reasons list.

NOTE The yellow text shows the type of alarm that has been recorded.

-
- 4 Select an alarm reason from the list. Push **ENTER**.
-

Set the Inert Gas and Altitude Values

After factory calibration, an inert gas can be selected. The particle counter applies a correction factor to the flow rate based on the inert gas selection.

-
- 1 On the Counter Navigation screen, push **SYSTEM**.

-
- 2 Select the **Custom** tab.

-
- 3 Select the Gas field, then select the gas to be tested.

NOTE Only the gases that the instrument has been calibrated with will show in the list.

-
- 4 Select the Altitude field.

-
- 5 Select the altitude of the measurement location. The altitude values are shown in feet.
-

Set the Particle Count Alert (Beep Function)

The instrument can be set to play a sound when an interval value is counted on a specified channel. For example, when the interval value is 100, the counter will beep each time it counts 100 particles.

-
- 1 On the Counter Navigation screen, push **SAMPLE**.

-
- 2 Select the **Settings** tab on the right side of the screen.

-
- 3 Select Quick Settings.

-
- 4 Push **YES** to edit settings for the default group.
-

-
- 5 Select the Run Mode field, then select **BEEP**.
-

Change the Relative Humidity and Temperature Probe

The standard relative humidity and temperature probe is used in most applications. If an HMP probe is needed, it can be selected on the **Units and Alarms** tab.

The scale of the standard probe and the HMP probe are different. When measurements are different than expected, make sure that the HMP probe is selected or deselected as needed.

-
- 1 On the Counter Navigation screen, push **SYSTEM**.
-
- 2 Select the **Units and Alarms** tab.
-
- 3 Select the **HMP RH/T** check box to activate or deactivate the HMP probe.
-

Manage Backup and Restore Settings

Users with administrator or System Settings permissions can make a backup of configurable settings, and restore the backup settings as needed.

Make a Backup of Configurable Settings

-
- 1 On the Counter Navigation screen, push **SYSTEM**.
-
- 2 Select the **Options and Accessories** tab.
-
- 3 Push **BACK-UP**.
An electronic copy of the current configuration is stored in instrument memory. This version can be restored with the Restore function.
-

Restore Settings from Backup

Use the Restore function when settings become corrupt, incorrectly modified or when the software performs abnormally.

1 On the Counter Navigation screen, push **SYSTEM**.

2 Select the **Options and Accessories** tab.

3 Push **RESTORE**.

4 Push **RESTART**.

Configurations

Specific configurations can be saved as a backup and/or copied as necessary between particle counters.

Copy a Configuration

To copy a configuration:

1 On the Counter Navigation screen, push **SYSTEM**.

2 Select the **Configuration** tab.

3 Insert a USB drive into the USB host connector. Refer to [Figure 3.3](#).

4 Push **COPY CONFIGURATION TO USB**.

5 A confirmation message will show. Push **OK**.

6 Remove the USB drive.

Install a Configuration

To install a configuration from a USB drive:

1 On the Counter Navigation screen, push **SYSTEM**.

- 2 Select the **Configuration** tab.
- 3 Insert the USB drive with the configuration data into the USB host connector. Refer to [Figure 3.3](#).
- 4 Push **READ CONFIGURATION FROM USB**.
- 5 A confirmation message will show.
- 6 Remove the USB drive.
- 7 Push **OK** to restart the instrument and load the new configuration.

Locations, Areas and Groups



A **location** defines a space, such as a work bench, that is identified for sample testing. To add, change or remove a location, refer to [Location Management](#).

An **area** is a group of defined locations that are geographically co-located. For example, Cleanroom A is an area. The work benches inside Cleanroom A may be defined as locations. To add, change or remove an area, refer to [Area Management](#).

Groups are locations that have common sampling attributes. For example, all locations that are tested every month may form one group. Locations in a group do not have to be co-located. To add, change or remove a group, refer to [Group Management](#).

Location Management

Add a Location

- 1 On the Counter Navigation screen, push **LOCATIONS**.
- 2 On the Area/Location Setup screen, select an existing area, or if needed, create a new area and then select it. Push **ADD LOCATION**.

3 In the Add Sample Location screen:

- Select the Location Name field. Enter the location name. Push **ENTER** to confirm.
- Select the Location ID field to specify a numerical ID for the location. The numerical ID is unique for each location and must be in the range of 000 – 999.

NOTE Use the **ALT** key to access special characters.

Edit a Location

1 On the Counter Navigation screen, push **LOCATIONS**.

2 On the Area/Location Setup screen, select an existing area.

3 Select **Edit Location**.

4 In the Add Sample Location screen:

- Select the Location Name field. Enter the location name. Push **ENTER** to confirm.
- Select the Location ID field to specify a numerical ID for the location.

NOTE Use the **ALT** key to access special characters.

Configure New Settings for the Location

1 On the Counter Navigation screen, push **LOCATIONS**.

2 On the Area/Location Setup screen, select an area.

3 Select a location within the area.

- Push **ADD LOCATION** to configure a new location.
 - Push **EDIT LOCATION** to change the configuration of a current location.
-

4 In the Add Sample Location screen, push **SETTINGS**.

-
- 5** Select the **General** tab.
 - Set the count cycles and the count mode.
 - Select the run mode.
 - Set the count display option.
 - 6** Select the **Timing** tab.
 - Set the duration for each sample.
 - Set the sample hold time between count cycles.
 - Set the sample delay time to allow delay before the sample test begins.
 - 7** Push **RETURN** to go back to the Add Sample Location screen.
-

Copy Settings from Another Location

- 1** On the Counter Navigation screen, push **LOCATIONS**.
 - 2** On the Area/Location Setup screen, select the area that includes the destination location.
 - 3** Select the location where the copied settings should go. Push .
 - 4** Push **YES** to confirm or push **NO** to cancel.
-

Set Location Alarms

The particle counter allows different alarm settings for individual locations.

NOTE Use this feature when the Use Location Settings is selected in Group Settings.

- 1** On the Counter Navigation screen, push **LOCATIONS**.
 - 2** On the Area/Location Setup screen, select an area.
 - 3** Select a location within the area. Push **ADD LOCATION** or **EDIT LOCATION** as needed.
-

4 In the Sample Location Setup screen, push **ALARMS**. The Alarm Settings screen has two tabs to configure.

5 In the **Count** tab:

- Edit the particle size
- Edit particle concentration limits

6 In the **Environment** tab:

- Enable the temperature alarm and set temperature limits.
- Enable the relative humidity alarm and set relative humidity limits.
- Enable the air velocity alarm and set air velocity limits.

NOTE These settings are only valid with the specific environmental probe attached to the instrument.

7 Push **RETURN** to confirm and go back to the Add Sample Location screen.

Remove a Location

1 On the Counter Navigation screen, push **LOCATIONS**.

2 On the Area/Location Setup screen, select an area.

3 Select a location. Push **REMOVE LOCATION**.

4 Push **YES** to delete the location or push **NO** to cancel.

Change the Order of Locations

Change the listed order of locations to change the sample order during testing.

1 On the Counter Navigation screen, push **LOCATIONS**.

2 On the Area/Location Setup screen, select an area.

3 Select a location. Push the **UP** or **DOWN** arrow to change the position of the location in the list.

4 Continue to select and move locations to create the needed order for samples.

NOTE Arrow keys can also be used to move a location to a different area.

Area Management

Add a New Area

Use up to 15 alphanumeric characters to name an area.

1 On the Counter Navigation screen, push **LOCATIONS**.

2 On the Area/Location Setup screen, push **ADD AREA**.

3 Enter the area name and confirm.

NOTE Use the **ALT** key to access special characters.

Edit an Area

1 On the Counter Navigation screen, push **LOCATIONS**.

2 On the Area/Location Setup screen, select an existing area.

3 Select **EDIT AREA**. Confirm.

NOTE Use the **ALT** key to access special characters.

Remove an Area

1 On the Counter Navigation screen, push **LOCATIONS**.

2 On the Area/Location Setup screen, select an area.

3 Push **REMOVE AREA**.

4 Push **YES** to delete the area or push **NO** to cancel.

Change the Order of Areas

Change the listed order of areas for ease of selection. Area order does not affect sample order.

1 On the Counter Navigation screen, push **LOCATIONS**.

2 On the Area/Location Setup screen, select an area.

3 Push the **UP** or **DOWN** arrow to change the position of the area in the list.

4 Continue to select and move areas to create the needed order.

Group Management



A group is a collection of sample parameters and settings that can include locations. The locations in a group do not need to be geographically co-located.

Push the \pm button on the sample screen to go to the next location in the active group.

Add a Group

1 On the Counter Navigation screen, push **GROUP**.

2 In the Group Settings Management window, select **<NEW>**. Enter the name of the group and confirm.

NOTE Use the **ALT** key to access special characters.

3 Push **SAVE**.

Install a Group

To enable a group, use the Load Group function.

1 On the Counter Navigation screen, push **GROUP**.

2 In the Group Settings Management window, select a group.

3 Push **LOAD**.

Delete a Group

1 On the Counter Navigation screen, push **GROUP**.

2 In the Group Settings Management window, select a group.

3 Push **DELETE**.

Add a Location to a Group

1 On the Counter Navigation screen, push **GROUP**.

2 In the Group Settings Management window, select a group.

3 Push **SETTINGS**.

4 Push **ADD LOCATION**.

5 Navigate to the needed location and select it, then push **OK**.

NOTE Push the **UP** or **DOWN** arrow to change the order of locations in the Group Settings screen. Refer to [Change the Order of Locations](#) for more information.

Sizes Function

IMPORTANT If a selected channel has not been calibrated, particle counts will be based on interpolation. A maximum of $\pm 15\%$ size error and a $\pm 30\%$ counter error can occur when samples are taken at an interpolated size point.



The Sizes function is a separate option that must be enabled by the manufacturer. The icon will not show on the Counter Navigation screen if this option has not been purchased. Customized channel sizes can be selected at time of order.

With the Sizes function enabled, the particle counter can be configured for the particle sizes that follow*:

- 0.3 to 10- μm range: 0.3, 0.4, 0.5, 0.7, 0.8, 1.0, 2.0, 3.0, 4.0, 5.0, 7.0 and 10.0
- 0.5 to 25- μm range: 0.5, 0.6, 0.7, 0.8, 1.0, 2.0, 3.0, 5.0, 7.0, 10.0, 15.0 and 25.0

NOTE Channel sizes 0.3 μm and 25.0 μm cannot be configured together.

Data Management

Store Partial Data

Data can be collected from sample measurements that have been stopped by a user or by a flow error.

1 On the Counter Navigation screen, push **SYSTEM**.

2 Select the **Custom** tab.

* Assumes 8-channel option is enabled

-
- 3 Select the **STORE PARTIAL DATA** checkbox.
-

NOTE Sample measurements collected during the execution of a Test Wizard that are stopped by a user or flow error are always stored, regardless of the setting of this flag.

Manage the Data Buffer

The data buffer allows the data to be preserved or overwritten. In addition, the size of the buffer can be changed and data can be cleared from the buffer.

Set the Data Buffer to Rotate Data

The default buffer setting is fixed. In this setting, no new data can be added to the buffer when it is full. When the buffer is set to rotate, new data can be added to a full buffer, while the oldest data record is deleted.

-
- 1 On the Counter Navigation screen, push **SYSTEM**.
-

- 2 Select the **Custom** tab.
-

- 3 Select **ROTATING BUFFER**.
-

Set the Data Buffer Size

A change to the buffer size causes all current buffer data to be lost and unrecoverable.

-
- 1 On the Counter Navigation screen, push **SYSTEM**.
-

- 2 Select the **Options and Accessories** tab.
-

- 3 Select the Data Buffer Size field. Enter a value between 50 and 5000.
-

- 4 Push **ENTER** to confirm.
-

- 5 Push **YES** to clear the data buffer.
-

Real-time PDF/CSV Option

Use this option to send the count data to a PDF file and if necessary to a CSV file. Secure PDF files are generated in real time or when sample data is selected from the instrument data buffer using the Export function.

Turn on the PDF Option

- 1 Push **SYSTEM**.
- 2 Select the **PDF** tab.
- 3 Enter the unlock code and push **ENTER**.
- 4 Select the options:

Option	Description
PDF on USB Detect	Automatically saves the real-time count data to a PDF file when the particle counter finds a USB memory stick in the USB port.
New Document On	Sets the criteria to start a new PDF file. New PDFs are made when an area or location changes or when the date changes.
Export Averages	Includes the average count of a set number of runs and the count data for each run to a PDF file.
Export to Excel	When a PDF file is made, the count data is also transmitted in .csv (comma separated value) spreadsheet format.
Warn when USB drive is X% full	Sets a notification that the USB memory stick is 50–95% full.

Save the Count Data to a Folder

Count data can be saved to a file with a filename that includes the date and time the file is created, or a unique identifier.

- 1 At the particle counter, make a folder to hold the count data. Select Date or enter a name for the folder.
- 2 Select **Configure File Name**.

-
- 3 Use up to seven criteria options to make a file name. Options include: area, date, time, location, user name, serial number or text.

When the file name is configured, the PDF is automatically saved to the folder.

-
- 4 Select **<None>** to remove a previous entry.
-

Manage Users and Permissions



Passwords allow the system administrator to restrict access to the instrument settings. When passwords are enabled, there are two levels of access:

- Administrator—Access to all settings on the instrument except for service (factory) access
- Operator—Access to review historical data and read current measurement values in the Diagnostics section. Operator access can also print historical or diagnostics data.

If password protection is not enabled, all users can access all functional settings of the instrument.

NOTE Factory settings are never accessible without a password.

Enable the User Logon Function

To enable user and password login:

-
- 1 Push **SYSTEM**.
-
- 2 Select the **Basic** Tab.
-
- 3 Select **User Logon Required**.
-

Log on as Administrator

-
- 1 On the Counter Navigation or Sample screen, push  to log off.
-
- 2 Select the User Name field. Enter "Admin". Push **ENTER**.

3 Select the Password field. Enter the default password "123456". Push **ENTER**.

4 Push **OK**.

NOTE To maintain system security, change the default administrator password. Refer to [Change the Password](#).

Change the Password

The password can be changed at the logon screen.

1 From the Counter Navigation screen, push Factory.

2 Push **CHANGE PASSWORD**.

3 Enter the username and push **ENTER**.

4 Enter the old password and push **ENTER**.

5 Select the New Password field. Enter a new password and push **ENTER**.

6 Select the Confirm Password field. Enter the new password again. Push **ENTER**.

7 Push **OK**.

Replace a Forgotten Password

If the System Administrator password is forgotten, contact technical support to get a new password. Technical support requires the information that follows to supply a new password:

- Instrument serial number
- Current date setting in the format MMDDYYYY, where MM is the two digit month, DD is the two digit day, and YYYY is the four digit year

Add a User

- 1 On the Counter Navigation screen, push **SYSTEM**.
- 2 Select the **Users** tab.
- 3 Push **ADD**.
- 4 Select the User Name field and enter a user name.
- 5 Select the Password field and enter a password.
- 6 Select the Confirm Password field and enter the same password.
- 7 Select the access level (Admin or Operator).

Assign Groups to a User

- 1 On the Counter Navigation screen, push **SYSTEM**.
- 2 Select the **Users** tab.
- 3 Select a user from the list.
- 4 Push **EDIT**.
- 5 Select the **Groups** tab.
- 6 Push **ADD**.
- 7 In the Select Group screen, select a group from the list.

8 Push **OK**.

Assign User Access Rights

1 On the Counter Navigation screen, push **SYSTEM**.

2 Select the **Users** tab.

3 Push **EDIT**.

4 Select the **Access Rights** tab.

5 Select or deselect access rights as necessary.

Option	Description
Sampling	The user can start a new count cycle.
Report Wizard	The user can access the report wizard to do sample protocols based on EU GMP (2015), ISO 14644-1:2015 or 1999, Federal Standard 209E, British Standard 5295, prior revision of EU GMP, or based on averages.
Historical	The user can search existing data records in the buffer.
Export	The user can export data to the USB stick based on the contents of the buffer or the filtered contents.
Printer	The user can use the different printer functions.
Group Settings	The user can set up or modify group settings.
Area/Location	The user can set up or modify area and/or location settings.
Group Select	The user can select the active group.
Group Admin	The user can add, edit or remove groups and can select the active group.
System Admin	The user can add or remove users, set date/time or any other function found under the System Settings menus.
Diagnostics	The user can see and print current diagnostic information.
Network	The user can access, see and change the network settings.
User Upload	The user can manually trigger the electronic transfer of count records through Ethernet (wired or wireless).

6 Push **OK**.



Log on to the Particle Counter



Prerequisites

- Start the system.
- Enable password protection. Refer to [Enable the User Logon Function](#).

-
- 1 Activate the backlight with a finger or stylus if needed.

 - 2 Push the  icon to log out a previous user. Push  again to see the logon screen.

 - 3 Enter the user name and password. Confirm.

NOTE Push the **ALT** key to access special characters.



Measure Particle Counts



After a complete particle count measurement, the number of particles measured will show on the screen and be stored as data. Other configured parameters, such as relative humidity, temperature and air velocity will be shown and stored in data.

-
- 1 Remove the protective cap from the inlet tube on the counter.

 - 2 On the Counter Navigation screen, push **SAMPLE**.

 - 3 To start the particle count, push . The  icon will change to a  button while the count is measured.

NOTE Push  to end the test before the count is complete. Incomplete particle count data will not be stored or printed unless the Save Partial Data option is selected in System Settings. Refer to [Store Partial Data](#).

-
- 4 When the count measurement is complete, the test will stop automatically.
-

Change the Particle Count Location

There are two methods to change the location for a particle count.

- On the Sample screen, push the location name. Select the new location name and confirm.
- On the Sample screen, push the **PLUS** button to increment the location, or push the **MINUS** button to decrement the location.

See Settings During the Particle Count

Location and group settings can be seen at any time during the particle count cycle.

- On the Sample screen, select the Settings tab on the right side of the screen.

See Historical Data During the Particle Count

Historical sample data can be seen at any time during the particle count cycle.

-
- 1 On the Sample screen, select the **ARROW** button.
-

- 2 Select the **HISTORICAL** icon to see the data.
-

Use the Filter Scan Probe

IMPORTANT The filter scan probe function applies to 1 CFM and 50 LPM units only.

-
- 1 On the Counter Navigation screen, push **SAMPLE**.
-

- 2 In the Test screen, push .
-

- 3 To start the test, push **START FILTER PROBE TEST**.
-

- 4 To end the test, push **STOP FILTER PROBE TEST**.
-

-
- 5 Push  to generate a brief report of the last completed test.
-

Manage Sample Batch Identification

Batch IDs are used to label different test runs. Labels can be text or numbers. The Batch ID is shown:

- On the main sample screen in the settings
- In the System Messages of the Historical screen
- In printed reports, FTP exports and all USB exports

Enter or Change a Batch ID

To enter or change a Batch ID:

-
- 1 On the Counter Navigation screen, push **SAMPLE**.
-
- 2 Select the **Settings** tab.
-
- 3 Select **BATCH ID**.
-
- 4 Enter the Batch ID as a text, numerical or alphanumeric string. The Batch ID can use up to 29 characters.
-
- 5 Push **ENTER**.
-

Disable a Batch ID

Disable the Batch ID to stop it from showing in data reports.

-
- 1 On the Counter Navigation screen, push **SAMPLE**.
-
- 2 Select the **Settings** tab.
-
- 3 Select **BATCH ID**.

4 Delete the Batch ID text.

5 Push **ENTER**. The default Batch ID value will show, but will not be reported.

Set or Clear the Batch ID

At the start of a sample test push **BATCH ID**. The user can select:

- Continue—Keep the Batch ID the same.
- Clear ID—No Batch ID is recorded with the sample cycle.
- Edit ID—Change the Batch ID for the current sample cycle.

The Batch ID can also be cleared when the sample cycle is complete.

How to Use the Test and Report Wizard

About Standard Sampling Protocols



Use the Test and Report Wizard for groups, areas and locations that require sample measurements and reports based on specific standards and regulatory guidelines. The 3400-series particle counters include sample strategies based on common international protocols such as EU GMP (2015 or prior revision), ISO 14644-1:2015 or 1999, Federal Standard 209E, and British Standard 5295.

The wizard steps through seven data entry points:

- Selection of the type of standard or regulatory guideline: EU GMP (2015 or prior revision), ISO 14644-1:2015 or 1999, Federal Standard 209E, British Standard 5295, or Averages (user-defined test protocols)
- Selection of the targeted class for the qualification of the room
- Occupancy state: As built, at rest, in operation
- Particle size or sizes to sample
- Unidirectional or non-directional air flow (for FS209E)
- Area of the room in square meters (m²)
- Samples per location. A minimum value is set based on room size and standard. This value can be increased as needed.

About Reports

ISO 14644-1, FS 209E and BS 5295 specify calculations for airborne particle counter count data. These documents establish the definitions for level of cleanliness in cleanrooms and clean zones based on specified concentrations of airborne particles. The printed reports provide the data to determine the cleanliness level for which that cleanroom qualifies.

Set up the Test and Report Wizard

1 On the Counter Navigation screen, push **TEST WIZARD**.

2 In the Test and Report Wizard screen, complete the fields listed in this step. Select the applicable listed options.

Option	Description
Standard	Shows the list of applicable standards
Grade/Class	Shows a list of room classification
Occupancy	Shows a list of room states

3 Select the Sizes field.

- a. Highlight a particle size.
- b. Push **ADD** to add the size to the Considered Sizes list.
- c. Add as many particle sizes as needed. To remove a particle size, select the size from the Considered Sizes list and push **REMOVE**.

4 Go to the next screen in the wizard.

- a. Enter the room area in m². Push **ENTER** to confirm.
- b. Enter the number of samples per location. Push **ENTER** to confirm.

5 Go to the next screen in the wizard.

- a. Push **ADD AREA**, **ADD GROUP** or **ADD LOCATION**. Individual locations will show in the Locations list when the group, area or location is added.
- b. Highlight a location. Use the **UP** or **DOWN** arrows to change the order of locations as needed. The order of the list will be the order of the test.

6 Go to the next screen. A confirmation of the selections will show.

Start Sample Measurement with the Wizard

- 1 Push **BEGIN SAMPLING**.
- 2 Obey the prompt and go to the first sample location. Push **OK**.
- 3 Put the isokinetic probe in position for the test. Push **RUN**.
- 4 Continue to obey the prompts and move to each location for the test. When all tests are complete, the counter will return to the wizard to configure the report.



NOTE With the ISO 14644-1:2015 standard, you will be prompted if you want to use sequential sampling. The sequential sampling technique measures the rate of counting and predicts the likelihood of passing or failing to meet the requirements of the selected ISO class. If the air being sampled is significantly more or significantly less contaminated than the specified class concentration limit for the considered particle size, use of the sequential sampling procedure can reduce sample volumes and sampling times, often dramatically. When sequential sampling is selected, the wizard will automatically make this determination and stop sampling early.

Use Existing Data

The Test and Report Wizard can include existing data for the selected standard and location.

- 1 Select the Use Existing Data checkbox.
- 2 Enter the date and time range for the existing data.
- 3 Push **BEGIN SAMPLING**.

Report Test Results

- Push  to send the selected data to a USB drive. Refer to [Export Data](#).
- Push  to print the selected data. Refer to [How to Use the Print Center](#).

How to Use the Print Center

About the Print Center

IMPORTANT To avoid damage to the printer, do not operate the printer without paper. If the particle counter must be used without paper, be sure to set the Sample Print Mode field to "None".



The particle counter has a built-in printer. The Print Center screen is accessible from the:

- Counter Navigation screen
- Historical screen
- System Diagnostics screen
- Test/Report Wizard screen
- Area/Location Setup screen

On the Print Center screen, the user can:

- Set automatic print functions
- Print buffer records or count averages

NOTE Filtered data is printed from the Historical screen.

Print Records Manually

The buffer holds 5000 records maximum. The Print Center can print the entire buffer or the average of count cycles obtained at each sample point. To print records manually:

-
- 1** On the counter Navigation screen, push **PRINTER**.

 - 2** On the Print Center screen, select the print option for the data. In the Print Report field, select the regulatory reports that will be printed.
 - Push **AVERAGE** to print the average of each size channel for the last sample measurement. Refer to [Figure 7.1](#).
 - Push **BUFFER** to print all of the records in the buffer. Refer to [Figure 7.2](#).

 - 3** The data will begin to print.
 - To cancel the print job, push **CANCEL PRINT**.
 - To return to Counter Navigation, push **RETURN**.
-

Figure 7.1 Averages report

```
---- PRINT AVERAGES ----

S/N ##### LOCATION ###
DATE YYYY-MM-DD TIME HH:MM:SS
CYCLES ### FLOWRATE ##.#LPM
PERIOD HH:MM:SS
COUNT SCALE:PARTICLES/CUBIC FT
TEMPERATURE ###.#F RH ###.##%
AIR VELOCITY #.#FT/MIN
SIZE CUMULATIVE DIFFERENTIAL
0.3µm 12345678.9 12345678.9
0.5µm 12345678.9 12345678.9
1.0µm 12345678.9 12345678.9
3.0µm 12345678.9 12345678.9
5.0µm 12345678.9 12345678.9
```

Figure 7.2 Buffer report (all buffer records)

```
---PRINT BUFFER, ##### RECORDS---

**** ALARM CONDITION ****

S/N ##### LOCATION ###
DATE YYYY-MM-DD TIME HH:MM:SS
CYCLES ### FLOWRATE ##.#LPM
VOLUME #.#FT^3 PERIOD HH:MM:SS
COUNT SCALE:PARTICLES
TEMPERATURE ###.#F RH ###.##%
AIR VELOCITY #.#FT/MIN
SIZE CUMULATIVE DIFFERENTIAL
0.3µm 12345678.9 12345678.9
0.5µm 12345678.9 12345678.9
1.0µm 12345678.9 12345678.9
3.0µm 12345678.9 12345678.9
```

Set Automatic Print Functions

NOTE If the sample period is very brief and the hold time is zero, the sending of some sample data to the printer may be skipped. However, the data is always obtained and saved. To avoid a printout failure, set the total time of the Sample period and the Hold period combined to more than 12 seconds.

- 1 On the Counter Navigation screen, push **PRINTER**.
- 2 On the Print Center screen, select the Sample Print Mode field. Select an option for automatic printing.

Option	Description
None	No data will print automatically
Alarms	Prints results at the end of the sample when a count alarm is exceeded
Cycles	Prints the results of multiples of the programmed count cycle. The range is 1-99.
All	Prints results after each count cycle is finished

- 3 Set the Cycle Print Order. Options: 10-1 (oldest printed first) or 1-10 (newest printed first).
- 4 To show the average of the values in the printout when the samples are taken and the data is printed, select **Print Averages**.
NOTE The fourth value in the printout is the average of the three previous values.
- 5 To round values to the nearest whole number, select **Round Averages**.
- 6 To repeat the header data on all samples, select **Repeat Sample Headers**. When not selected, the headers print only with the first sample of a series when the cycles are set to > 1.
- 7 Push **ENTER** to confirm.

Review Historical Buffer Data



Records stored in the buffer are known as Historical data. These records can be accessed individually or sorted by location, date or time. The buffer can also be configured to collect partial data for aborted samples.

Set the Data Filter

The data filter can be set up to sort by location, date and time, either as individual parameters or in combination. To set the data filter, go to the Data Filter Setup screen.

1 Push  to go to the Data Filter Setup screen.

2 Select a filter option.

Option	Description
Filter by location	Check all of the locations to be included in the results. Push ALL to select all locations, or push NONE to deselect all locations.
Filter by date	Enter dates in the DATE FROM and DATE TO fields. Dates are in YYYY-MM-DD format.
Filter by time	Enter the needed times in the TIME FROM and TIME TO fields. Time is in HH:MM:SS format.

Clear the Data Buffer

Data that has been exported or is not needed can be deleted from the buffer.

1 On the Counter Navigation screen, push **SYSTEM**.

2 Select the **Options and Accessories** tab.

3 To erase all the data in the buffer, push **CLEAR BUFFER**.

Export Data



Export data to maintain an electronic record for analysis and reporting.

1 On the Counter Navigation screen, push **EXPORT**.

2 Select **USB Flash Drive** or **Network server**.

NOTE To export data to a network server, configure and enable the FTP function. Refer to [Configure and Enable the FTP Function](#).

3 Select PDF, Comma Separated File, Tab Separated File, XML or PortAll.

NOTE The PDF option shows only after the PDF option has been set to on. Refer to [Turn on the PDF Option](#).

4 If PDF was selected and the settings on the PDF tab under System Settings should be used, select the box to enable PDF Page and File Break Rules.

5 If needed, change the default file name and confirm.

6 If USB Flash Drive was selected, insert the USB drive into the USB host on the front of the instrument. If the USB Flash Drive is not inserted, a warning will show on the screen. The warning will change to a confirmation after the USB Flash Drive is inserted.

7 Push **EXPORT**. The status bar will show the progress.

NOTE To stop the export, push .

About Status Values in Exported Data

The status value represents several elements of unit status. Environmental, count and concentration alarms can be indicated in the status value.

To determine the alarm conditions present in the report, subtract the largest possible value that represents a bit from the Status value in the exported data. Refer to [Table 7.1](#).

Table 7.1 Sample Status Bit Mask Definitions

Bit	Value	Definition	Bit	Value	Definition
0	1	Calibration	16	65536	Channel 3 concentration alarm
1	2	Flow	17	131072	Channel 4 concentration alarm
2	4	Temperature	18	262144	Channel 5 concentration alarm
3	8	Relative humidity	19	524288	Channel 6 concentration alarm
4	16	Air velocity	20	1048576	Channel 7 concentration alarm
5	32	Manifold alarm	21	2097152	Channel 8 concentration alarm
6	64	Count alarm	22	4194304	Channel 9 concentration alarm
7	128	Concentration alarm	23	8388608	Channel 10 concentration alarm
8	256	Channel 1 count alarm	24	16777216	Channel 11 concentration alarm
9	512	Channel 2 count alarm	25	33554432	Channel 12 concentration alarm
10	1024	Channel 3 count alarm	26	67108864	Channel 7 count alarm

Table 7.1 Sample Status Bit Mask Definitions

Bit	Value	Definition	Bit	Value	Definition
11	2048	Channel 4 count alarm	27	134217728	Channel 8 count alarm
12	4096	Channel 5 count alarm	28	268435456	Channel 9 count alarm
13	8192	Channel 6 count alarm	29	536870912	Channel 10 count alarm
14	16384	Channel 1 concentration alarm	30	1073741824	Channel 11 count alarm
15	32768	Channel 2 concentration alarm	31	2147483648	Channel 12 count alarm

Configure and Enable the FTP Function

With firmware V4.09, the particle counter can be configured to transmit data via Ethernet (wired or wireless when the wireless option is installed) to an FTP server. This particle counter can connect to servers that use FTP or FTPS (Explicit TLS/SSL).

- 1 For the user account that will be used in the particle counter, give *file* access on the FTP server: Read, Write and Delete.
- 2 For the user account that will be used in the particle counter, give *directory* access on the FTP server: Create, Delete, List and Add Subdirectories.

NOTE The Create, Delete and Add Subdirectories rights are only necessary if the particle counter will be configured to make subdirectories. These rights are not necessary when the particle counter is configured to use the existing directories.
- 3 On the Counter Navigation screen, push **EXPORT**.
- 4 Select **Configure FTP**.
- 5 Select **Network Server Enabled**.
- 6 In the Host/IP Addr field, enter the host name or the IP address of the computer where the FTP server is installed.
- 7 In the Port field, enter the port number on which the FTP server listens.
- 8 In the Protocol field, select the protocol the FTP server uses (FTP or FTPS (TLS/SSL)).

9 Optional: In the Initial Folder field, enter the initial folder where files will be kept. Leave blank to save files to the root.

10 Select the **Logon** tab.

11 In the Authentication field, select Anonymous or Normal.

12 If Normal was selected, enter a user name and password to use for authentication with the FTP server.

13 Push **Test Connection**. When the connection is successful, "Test Connection Succeeded" shows.

NOTE If the connection was not successful, an error message shows with the reason.

Data Transfer to the OPC Server

Only administrators, factory service personnel and operators with User Upload permission can initiate data upload to the OPC server.

There are three settings that control the data transfer to the OPC server: User initiated upload, user-initiated download and automatic download.

User-initiated Data Upload

Use this option to control when data is sent to the server.

1 Go to the Network screen.

2 Push  to initiate the data transfer.

User-initiated Data Download

User-initiated download is done from the OPC server. Use this option to verify the server connection and start the data download.

To start the data download, push **DOWNLOAD NOW**. All other actions are done by the server.

Automatic Data Download

Automatic download is configured on the OPC server. For applications that require alarm reasons, automatic download must be disabled.

 **WARNING**

 **Multiple hazards. Do not disassemble the instrument for maintenance. If the internal components must be cleaned or repaired, contact the manufacturer.**

 **CAUTION**

 **Multiple hazards. Only qualified personnel must conduct the tasks described in this section of the document.**

Clean the Instrument Exterior

The instrument exterior can be cleaned as needed. To avoid human exposure to potentially dangerous chemicals, make sure to clean the touchscreen immediately after contact with chemicals.

IMPORTANT To prevent damage, do not use an aerosol cleaner or glass cleaner on the touchscreen. Do not leave visible moisture on the instrument or touchscreen. Moisture can penetrate the touchscreen and damage the electronics inside.

- 1 Put the cap on the sample air intake nozzle to keep contamination out.
 - 2 Spray a mild cleaning solution on a soft cloth. Wipe the outside of the instrument carefully.
 - 3 Use a soft, dry cloth to wipe the touchscreen surface. If needed, moisten the soft cloth with a mild cleaning solution.
-

Set the Count to Zero

Do this procedure after unexpectedly high particle counts. This procedure will verify that the particle counter works correctly and will remove residual particles.

-
- 1 Put the zero-count filter on the intake tube.

 - 2 Turn on the unit and log in if needed.

 - 3 Push **SAMPLE**.

 - 4 Push **RUN**.

 - 5 Repeat the process until the particle counts return to zero.
-

Update the Instrument Software

IMPORTANT Do this procedure with only manufacturer-supplied files and directions.

-
- 1 Download the self-extracting *.zip file from the location provided by the manufacturer.

 - 2 Extract the files to a compatible USB drive. Use only manufacturer-supplied USB drives for best results.

 - 3 Remove AC power. Remove the batteries.

 - 4 Plug the USB drive into the USB port.

 - 5 Apply AC power to the instrument.

 - 6 Select **Yes** to start the update. When the update is complete, the instrument will continue startup.

 - 7 To verify the version number of the update, push **DIAGNOSTICS**. The version will show on the Diagnostics screen.
-

Charge the Batteries in the Particle Counter

Batteries in the particle counter will begin to charge when the AC power adapter is connected. A complete charge in the instrument takes approximately 10 hours. The battery is considered to be fully charged when the display shows a charge between 95% and 100%.

Prerequisite: Install the batteries in the instrument. Refer to [Install the Batteries](#).

IMPORTANT Discard the used batteries according to local regulations or contact the manufacturer. Do not put exhausted batteries in the domestic waste.

- 1 Attach the power supply to the unit.
- 2 Connect the unit power supply to the external power through the AC power adapter. The battery status light will show the level of power in the battery. Refer to [Table 8.1](#).

Table 8.1 Battery LED Color Indications

LED state	LED color	Battery status	Charge status
Flashing	Orange	Low power	Not charging
Flashing	Green	Low power	Charging
Solid	Green	Charged	Charging

Battery Recharge Intervals

[Table 8.2](#) shows the charge frequency that will increase battery life and increase the interval between battery calibrations.

Table 8.2 Suggested Battery Recharge Interval

Frequency of use	Hours of sampling			
	0.5	1	2	6
Daily	Charge weekly	Charge weekly	Charge daily	Charge daily
Weekly	Charge monthly	Charge weekly	Charge weekly	Charge weekly
Monthly	Store on charge	Store on charge	Store on charge	Store on charge

When the particle counter is not in use, batteries will slowly discharge because of background processes on the instrument.

Calibrate the Battery

The lithium ion Smart Battery will tolerate frequent partial discharges. After many partial discharges, the accuracy of the battery gauge is decreased.

To calibrate the battery charge gauge, set the optional, external Smart Charger to calibration mode during discharge.

Diagnostics and Troubleshooting



The Diagnostics screen shows information that may be needed for troubleshooting. Table 9.1 shows an example of a failure notification on the Diagnostics screen.

Table 9.1 System Diagnostics Screen Example - Clock Battery Failure

Signal	Value	Status
Calibration	0.00 VDC	OFF
Flow	0.00 VDC	OFF
Clock battery	0.00 VDC	FAIL
Battery 1 (bottom)	16.42 VDC	PASS
Battery 2 (top)	16.44 VDC	PASS
Laser current	N/A	--

For troubleshooting that involves technical support from the manufacturer, the user may need to send a fax of the system status printout to technical support.

1. On the Counter Navigation screen, push **DIAGNOSTICS**. Information about the system, such as serial number and software version, shows.
2. On the Diagnostics screen, push .

The printout will show the serial number, date and time and other data about the system.

Factory Settings



For troubleshooting that involves technical support from the manufacturer, the user may need to send a copy of the factory settings to technical support.

NOTE Factory settings cannot be changed by the user.

To view the factory information including the calibration date:

- 1 Log on as an administrator.
- 2 On the Counter Navigation screen, push **FACTORY**. The factory settings show (e.g., calibration date, calibration due date and nominal flow).

3 Push  to print the factory settings.

Parts and Accessories



WARNING



Personal injury hazard. Use of non-approved parts may cause personal injury, damage to the instrument or equipment malfunction. The replacement parts in this section are approved by the manufacturer.

NOTE Product and Article numbers may vary for some selling regions. Contact the appropriate distributor or refer to the company website for contact information.

Parts for the 28.3 LPM Counter (3413 and 3415)

Description	Quantity	Item number
Probe, isokinetic, aluminum, for 28.3 LPM	1	2087966-01
Probe, isokinetic, stainless steel, for 28.3 LPM	1	2087966-02
Filter, Zero Count for 28.3 LPM	1	2087939-01
Tubing, Hytrel®, 0.953 cm (0.375 in.) ID, 1.27 cm (0.5 in) OD (per foot)	1 ft	960380

Parts for the 50 LPM Counter (3423 and 3425)

Description	Quantity	Item number
Probe, isokinetic, aluminum, for 50 LPM	1	2088925-01
Probe, isokinetic, stainless steel, for 50 LPM	1	2088925-02
Filter, Zero Count for 50 LPM	1	2087939-01
Tubing, Hytrel®, 0.953 cm (0.375 in.) ID, 1.27 cm (0.5 in) OD (per foot)	1 ft	960380

Parts for the 100 LPM Counter (3445)

Description	Quantity	Item number
Probe, isokinetic, aluminum, for 100 LPM	1	2088978-01
Probe, isokinetic, stainless steel, for 100 LPM	1	2088978-02

Description	Quantity	Item number
Filter, Zero Count for 100 LPM	1	2087939-02
Tubing, Hytrel®, 1.334 cm (0.525 in.) I. D. (per foot)	1 ft	480-100-0041

3400 Series Parts

Description	Quantity	Item number
Battery, Lilon Smart	1	280-120-2024
Smart battery charger	1	280-300-5000
Brush, intake nozzle cleaning	1	995240
Paper, thermal, roll	1	460519
Power cord, 110 VAC	1	VP623501
Power cord, 220 VAC	1	VP6233500
Power supply, external, 100–240 VAC input, +24 VDC output	1	230-300-7052
WiFi antenna (for wireless versions only)	1	490-200-0001
Stylus for touchscreen interface	1	210-400-5171
Isoprobe, adapter	1	2088035-01
Isokinetic probe stand (optional) (compatible with all Iso-kinetic probes), stainless steel	1	2089406-01
USB flash memory drive kit ^a	1	210-400-0128
Probe, RH/T	1	2088928
Probe with beeper, filter scanning	1	2088000-01
Probe without beeper, filter scanning	1	2088000-02
Transportation case with foam inserts and wheels	1	710-200-0002
IQOQ validation document, V4.09.XX, CD	1	Contact Us
Low pressure diffuser, 15–49 PSI, 1 CFM only	1	2088616-01
High pressure diffuser, 100 L/min and 50 L/min, 1/2-in. barb	1	2080732-11
High pressure diffuser, 50 L/min (1.77 CFM), 3/8-in. barb	1	2080732-12
High pressure diffuser, 28.3 L/min (1.0 CFM), 3/8-in. barb	1	2080732-13
USB 2.0 high speed, 1 m (3.3 ft) cable	1	460-400-4798
USB to RS-232 adapter, DB-9 null modem	1	2088012-02
USB to RS-485 adapter	1	2088012-01

a. Use only the manufacturer-supplied USB flash drives.

Spare Parts Kit (2087919-01)

Description	Quantity	Item number
Battery, Lilon Smart Battery	1	280-120-2024
Charger, external battery	1	280-300-5000
Thermal paper, roll	1	460519

Related Documents

MET ONE 3400, Instructions for Use

PN DOC026.53.80202

- Specifications
- General Information
- Installation
- Network and Communication
- Particle Counter Navigation
- Configuration
- Operation
- Maintenance
- Diagnostics and Troubleshooting
- Parts and Accessories

www.beckmancoulter.com

