

# Interface Probe With ORS-Style Frame

Installation and Operation Manual





## Table of Contents

Section 1: System Description .....	3
Section 2: System Installation .....	9
Section 3: System Operation .....	10
Section 4: System Maintenance .....	12
Section 5: System Troubleshooting .....	13
Section 6: System Specifications .....	15
Section 7: System Schematic .....	17
Section 8: Replacement Parts List .....	18
Appendix A – Tripod Mount and Tape Guide .....	20
Appendix B – Chemicals and Decontamination .....	22
Warranty and Repair .....	28

## DOCUMENTATION CONVENTIONS

This uses the following conventions to present information:



**WARNING**

An exclamation point icon indicates a **WARNING** of a situation or condition that could lead to personal injury or death. You should not proceed until you read and thoroughly understand the **WARNING** message.



**CAUTION**

A raised hand icon indicates **CAUTION** information that relates to a situation or condition that could lead to equipment malfunction or damage. You should not proceed until you read and thoroughly understand the **CAUTION** message.



**NOTE**

A note icon indicates **NOTE** information. Notes provide additional or supplementary information about an activity or concept.

# Section 1: System Description

## Function and Theory

The Geotech Interface Probe with ORS-Style Frame (Interface Probe) is a hand held, battery powered device used for measuring depth to water or oil in tanks or wells. The Interface Probe can be used in numerous applications including measuring oil and water levels in monitoring wells, detecting tank leakage, and obtaining accurate measurements of water levels in cascading wells.

Interface Probe assemblies come with either 100' of Engineering tape or 30 meters of Metric tape. Part numbers for all models, including tape replacements and accessories can be found listed in Section 8.

The Interface Probe assembly consists of a hydrocarbon/water sensing probe, a measuring tape/probe cable and a housing into which the tape and probe can be withdrawn when not in use. Other Interface Probe features are:

- Rugged, durable, lightweight construction.
- Dependable, highly accurate.
- Trigger-style brake lever.
- Easy to use for controller programming.
- Grounding clip provided for anti-static safety.
- Automatic sleep function (power conservation mode).
- Reliability.
- Made in USA.

Figure 1-1 shows an example of the Small Diameter Interface Probe. Figure 1-2 shows an example of the Large Diameter Interface Probe. The housing and electrical on the Large Diameter IP are the same as that of the Small Diameter IP, with the exception of the probe and tape assembly (explained later in this section).

Some Interface Probe options are:

- Field replaceable sensing prism (large diameter probes only).
- Chemically resistant probe available on large diameter models.
- Optional small diameter probe is only  $\frac{5}{8}$ " (15.9 mm) in diameter.

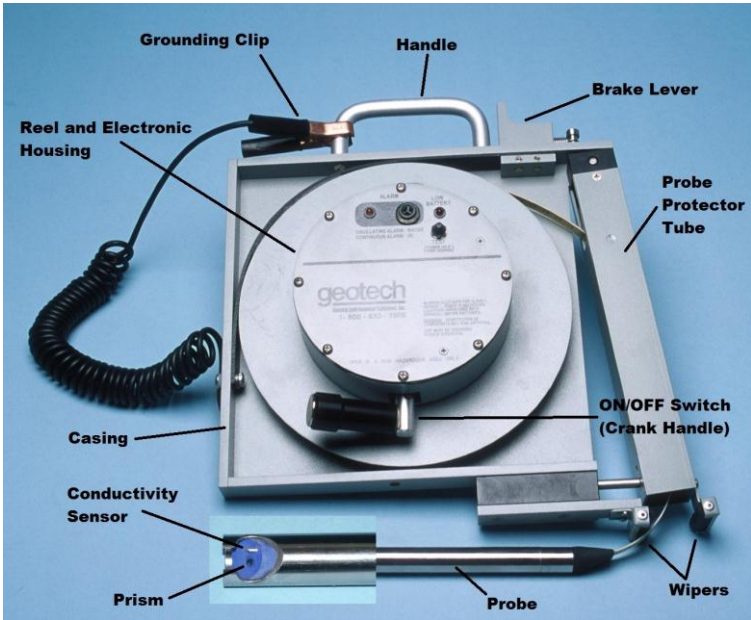

Figure 1-1 – Small Diameter Interface Probe



Figure 1-2 – Large Diameter Interface Probe (used for Chemical applications also)

## System Components

### Probes

Three probes are available for use with the Interface Probe assembly. The tape assembly is unique in that its length is cut to match the type of probe used and will have a unique, potted strain relief to match the probe body (as shown in the following figures.)

#### Small Diameter Interface Probe

The Small Diameter Interface Probe (Figure 1-3) is a  $\frac{5}{8}$ " (15.875 mm) diameter cylinder which can be used in wells as small as  $\frac{3}{4}$ " (19 mm) in diameter. The probe contains two different sensor units, one for detecting the liquid/air interface, and one for distinguishing between water and hydrocarbon.

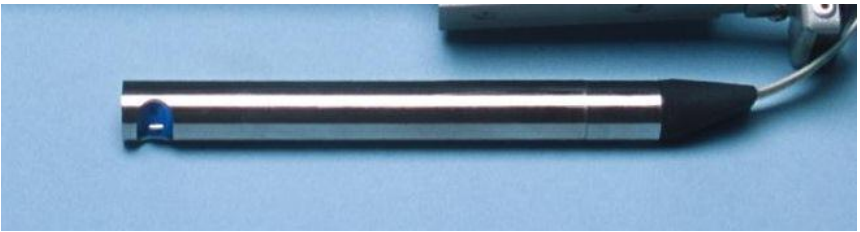

Figure 1-3 – Small Diameter Interface Probe

The liquid sensor is an optical PCB containing an emitter and detector that are located within the blue head of the probe. This sensor detects liquid by reacting to the differences in the indices of refraction of air and liquids. An infrared light source is internally reflected to an infrared detector by a prism built into the face of the sensor. When the head of the probe becomes immersed in liquid, the light beam is refracted from the detector.

To determine if the liquid is conductive (water) or non-conductive (hydrocarbon), a small Intrinsically Safe electrical current is passed between the conductivity sensor and the probe body. Current flow will occur only in conductive fluids such as water. The Interface Probe is capable of measuring oil slicks less than 1/16 of an inch (1.6 mm) in thickness.

## Large Diameter Interface Probe

The Large Diameter Probe (Figure 1-4) is a 1" (25.4 mm) diameter cylinder which can be used in wells as small as 1.125" (28.575 mm) in diameter. The probe contains two different sensor units, one for detecting the liquid/air interface, and one for distinguishing between water and hydrocarbon.



Figure 1-4 – Large Diameter Interface Probe

The liquid sensor is an optical prism located on the end of the probe. This sensor detects liquid by reacting to the differences in the indices of refraction of air and liquids. An infrared light source is internally reflected to an infrared detector by a prism on the face of the sensor. When the prism becomes immersed in liquid, the light beam is refracted away from the detector.

To determine if the liquid is conductive (water) or non-conductive (hydrocarbon), a small Intrinsically Safe electrical current is passed between the conductivity sensor and the probe body. Current flow will occur only in conductive fluids such as water. The Interface Probe is capable of measuring oil slicks less than 1/16 of an inch (1.6 mm) in thickness.



## Large Diameter Chemical Interface Probe

The Large Diameter Chemical Interface Probe (Figure 1-5) is a 1" (25.4 mm) diameter cylinder which can be used in wells as small as 1.125" (28.575 mm) in diameter. It is constructed of glass, stainless steel, epoxy and Teflon® to resist chlorinated compounds and other corrosive substances. The probe contains two different sensor units, one for detecting the liquid/air interface, and one for distinguishing between water and hydrocarbon.



Figure 1-5 – Large Diameter Chemical Interface Probe

The liquid sensor is an optical prism located on the end of the probe. This sensor detects liquid by reacting to the differences in the indices of refraction of air and liquids. An infrared light source is internally reflected to an infrared detector by a prism on the face of the sensor. When the prism becomes immersed in liquid, the light beam is refracted away from the detector.

To determine if the liquid is conductive (water) or non-conductive (hydrocarbon), a small Intrinsically Safe electrical current is passed between the conductivity sensor and the probe body. Current flow will occur only in conductive fluids such as water. The Interface Probe is capable of measuring oil slicks less than 1/16 of an inch (1.6 mm) in thickness.

## Measuring Tape

The specially coated measuring tape connects the probe with the housing assembly and provides an accurate means of measuring the distance from the well head or tank port to the air/water, air/oil or oil/water interface. The tape contains all the wires running between the probe and the circuitry in the housing assembly. Engineering tape assemblies are in decimal feet and Metric tape assemblies are in meters (down to millimeters).

Tape assemblies and probes come as a set. If an alternate probe is required, such as switching from a small diameter to a large diameter, then the tape assembly will need to change also.

## Housing Assembly

The components of the weatherproof NEMA 3 housing assembly (also known as an ORS-Style Frame) are shown in Figure 1-1. The housing includes a casing and reel to protect and deploy the measuring tape and probe. The housing also has a Low Battery indicator, a visual/audible alarm and a test button and light to check the alarm. A ground assembly comes attached to the housing.

## Intrinsic Safety & Approval



The intrinsic safety and approval of the Interface Probe assembly is subject to the following requirements:

- Batteries must be changed only in a non-hazardous location.
- Batteries must be Duracell Type MN1500 (size AA). Substitution will impair intrinsic safety and void approval. Alternate battery types will also affect the operation of the Interface Probe.
- When in operation, the unit must be grounded with the grounding clip provided. Replace damaged or torn ground clip assemblies.
- Substitution of components and/or improper use will impair intrinsic safety and void approval.

## **Section 2: System Installation**

Installation of the Interface Probe is easy using the following steps:

1. Attach the grounding clip to a confirmed ground before lowering the probe.
2. Pull the Interface Probe protector tube out from the housing.
3. Raise the crank handle up to activate the unit.
4. Depress the test button to test. A yellow light and tone will signify there is power and tone.
5. Using the crank handle, in conjunction with the thumb driven brake latch, the probe can be released and lowered into the well. No further preparation is required.

When suitable, the Interface Probe assembly can be easily mounted to a tripod. See Appendix A for more information on using a tripod and for installing tape protection to the well head.

## Section 3: System Operation

### Taking a Measurement



Before activating the probe, attach the grounding clip to a suitable earth ground.

To turn the unit on, lift the crank handle away from the reel housing (see Figure 1-2). This activates a power switch inside the reel's electrical housing. To verify that the unit is operational, press the test button on the faceplate. If the power is ON, an audible tone will sound and the yellow alarm light will activate. A low battery condition will cause the red Low Battery indicator to be illuminated.



Before replacing the batteries, read the section on Intrinsic Safety and Approval within Section 1.

To release the probe, pull the protector tube outward from the reel casing. To lower the probe, tilt the front of the reel housing forward and press the brake release. The brake release is located just forward of the handle. The tape will reel out as long as the brake release is pressed. Lower the probe into the well taking care not to allow the probe or tape to rub against the well casing or any other sharp edge. Refer to Appendix A for an alternative means of probe deployment and tape protection.

When the probe contacts liquid, the visual/audible alarm on the reel will activate. A continuous alarm indicates hydrocarbon. An oscillating alarm indicates water.

To determine the exact thickness of a hydrocarbon layer, the probe should be slowly lowered to the air/hydrocarbon interface until the alarm is activated. With the probe at the exact point where the alarm comes on, read the numbers on the tape to determine the distance from the top of the well head to the air/hydrocarbon interface.

Next, lower the probe through the hydrocarbon layer and into the water. An oscillating alarm will be obtained. The probe should then be raised slowly to the hydrocarbon/water interface until the point is reached where the alarm changes from oscillating to continuous. The thickness of the hydrocarbon layer is determined by subtracting the first reading from the second reading.



The most accurate results are obtained by moving the probe as slowly as possible. It is important that the probe be removed from the fluid slowly. If not, drops of fluid may remain on the probe tip giving a false indication of liquid after it has been removed.

After taking a measurement, snap the protector tube shut so the wipers rest against the tape. Release the brake and slowly reel in the tape until the probe is just below the wipers. Do not allow the probe to bottom out against the wipers, as this will apply stress to the tape and possibly damage connections at the probe.

Next, open the protector tube and gently reel the probe 2/3 of the way into the tube. Forcibly reeling the probe all the way into the tube may stress or break the measuring tape. Now, turn the entire Interface Probe assembly upside down so that the probe will fall the rest of the way into the protector tube. After ensuring that the probe is entirely within the protector tube, close the protector tube.

The Interface Probe is equipped with an automatic shutoff circuit. If the probe has not sensed liquid within 4 minutes from the time power is applied, the unit will automatically switch to a low power mode. This prevents battery drain in the event the power is left on accidentally. To restore power, place the handle in the OFF position and then back to the ON position.

## Changing the Batteries

Should you receive a low battery condition when powering on the unit, replace the batteries as follows:

1. Using a Phillips screwdriver, remove the 8 screws to the electrical cover.
2. Carefully remove the cover and lay it to one side (do not tug or pull on the wiring). Figure 3-1 shows the location of the battery pack within the electrical housing.
3. Pull out the battery pack and remove the six AA batteries. Replace the batteries with Duracell Type MN1500 only.
4. Reinstall the battery pack and re-attach the cover. Test the unit for proper operation.

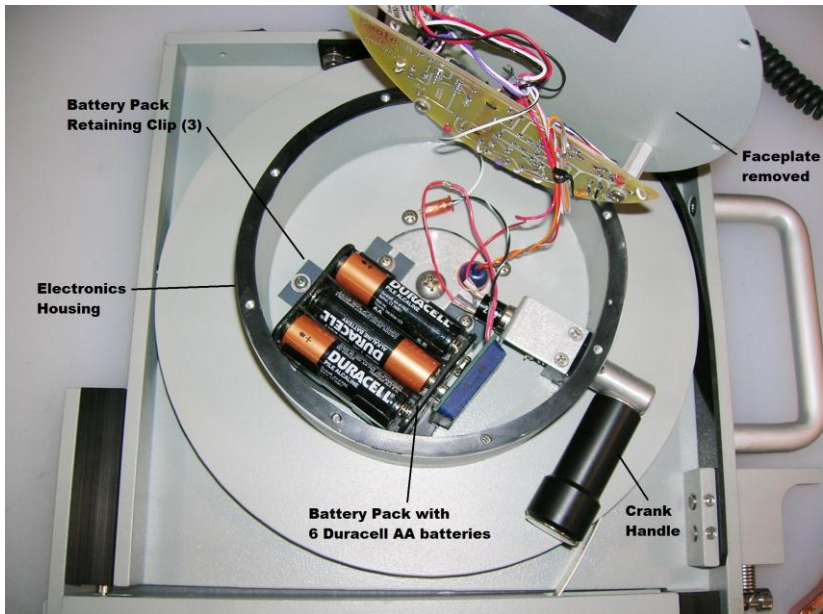

Figure 3-1 – Location of Interface Probe Battery Pack

## Section 4: System Maintenance

The Interface Probe is designed to be virtually maintenance free. The only maintenance required is cleaning off the tape, reel, and probe and periodic replacement of the batteries.

After taking measurements wash the probe in Alconox detergent, rinse in distilled water, then repeat the washing process once more. Clean all accessible parts of the reel assembly. Under some circumstances, a more aggressive cleaner may be required to prevent cross-contamination of wells. Keep abrasives from the probe lens.

Before replacing the batteries, read the section on Intrinsic Safety and Approval within Section 1.

To maintain the life of your Interface Probe make every effort to prevent the following:

- Do not allow the probe to impact a hard surface.

A fractured lens, prism or broken sensing post will require replacement of the probe or prism.

- **Never** allow the tape to hang across a sharp edge.

A cut on any part of the tape assembly will promote corrosion, incorrect readings and require that the tape assembly be replaced. Always use a tape guide on well heads or other sharp surfaces.

- Prevent leak points to the electrical housing.

If the LED lights are broken or pushed into the unit or the test switch boot is torn, these can become areas for water to enter the unit and damage the circuitry. Protect the surface of the housing by keeping the Interface Probe within its case. Never place other equipment on top of the Interface Probe.

## Section 5: System Troubleshooting

If an audible/visual alarm cannot be obtained, check the following:

- Ensure the crank handle is upright on the electrical housing.
- Verify that the batteries are good or that there is not a Low Battery condition.
- Verify that debris is not blocking the probe lens or conductivity sensor.
- Inspect the tape for cuts – especially along the sides of the tape.



The probe and tape assembly are part of a sealed unit and are not easily repaired in the field. The probe body and tape assembly can be replaced, but only within the proper environment by a qualified technician.

Before considering repairs, contact customer service at Geotech. Any major malfunction should be referred to the Customer Service Department, Geotech Environmental Equipment, Inc. at (800) 833-7958 or (303) 320-4764.

### Replacing the prism assembly on a Large Diameter Interface Probe

To remove the prism, use an adjustable wrench and carefully unthread the prism assembly from the probe bottom. The prism assembly is made up of three parts (as shown in Figure 5-1).



To prevent water from entering the prism cavity, carefully dry the probe before removing the old prism. Throughout the prism removal and replacement procedure, hold the probe with the prism pointed downward.

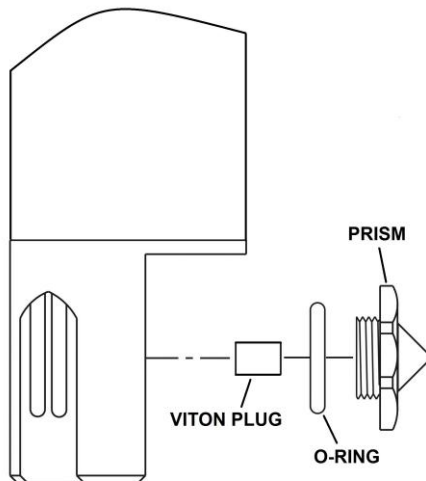

Figure 5-1 – Large Diameter Prism Assembly

Thread the new prism assembly into place by hand finger tight. Using the adjustable wrench firmly seat the prism and o-ring to the head. Be careful not to over tighten or the prism and/or probe head can crack. Always avoid scratching the prism surface with any tools or abrasives. Replacement prism assembly part numbers can be found in Section 8.

### Replacing the Prism on a Large Diameter Chemical Interface Probe

To remove the chemical probe prism, use an adjustable wrench and carefully unthread the SS prism nut from the probe bottom. The prism assembly is made up of four parts (as shown in Figure 5-2). Remove the prism and o-ring. Place the o-ring onto the new prism.



To prevent water from entering the prism cavity, carefully dry the probe before removing the old prism. Throughout the prism removal and replacement procedure, hold the probe with the prism pointed downward.

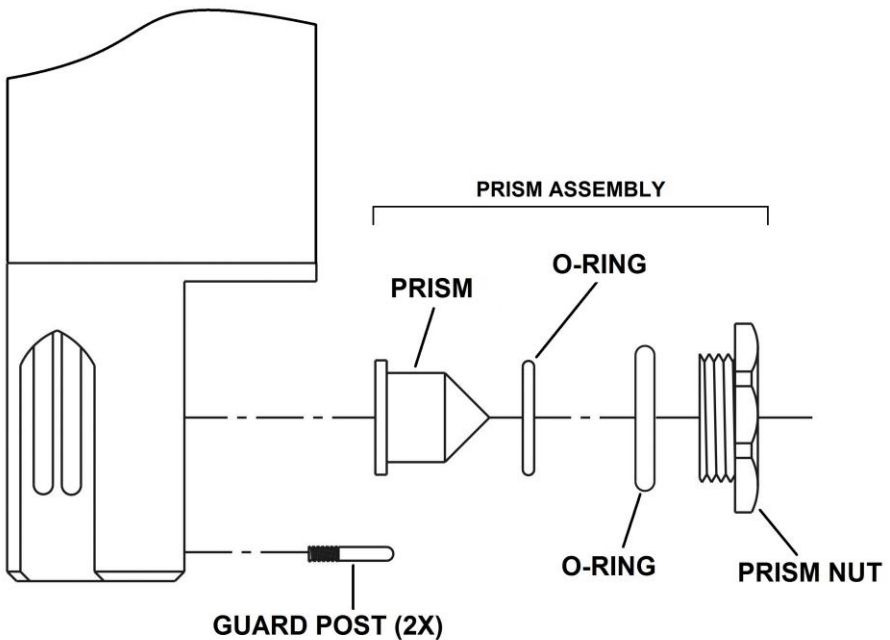

Figure 5-2 – Large Diameter Chemical Interface Probe Prism Assembly

Insert the prism into the nut and thread the assembly into place by hand finger tight. Using the adjustable wrench firmly seat the prism nut and o-ring to the head. Be careful not to over tighten or the prism and/or probe head can crack. The replacement prism and guard post part numbers can be found Section 8.



## Section 6: System Specifications

### Small Diameter Interface Probe

Material:	316 stainless steel, PTFE, Viton
Weight:	4.1 oz / 115 grams
Diameter:	.625 inches / 16 mm
Length:	6.55 inches / 16.6 cm
Probe waterproof to:	100 psi / 6.9 bar
Maximum probe shock:	10 G
Conductivity sense range:	> .78 $\mu$ S
Min. detectable hydrocarbon thickness:	.0312" / <.8 mm

### Large Diameter Interface Probe

Material:	304 stainless steel, epoxy, Radel
Weight:	4.6 oz / 130 grams
Diameter:	1 inch / 25 mm
Length:	6.5 inches / 16.5 cm
Probe waterproof to:	100 psi / 6.9 bar
Maximum probe shock:	10 G
Conductivity sense range:	> .78 $\mu$ S
Min. detectable hydrocarbon thickness:	.0312" / <.8 mm

### Large Diameter Chemical Interface Probe

Material:	Pyrex®, stainless steel, epoxy, Teflon®
Weight:	4.6 oz / 130 grams
Diameter:	1 inch / 25 mm
Length:	6.5 inches / 165 mm
Probe waterproof to:	100 psi / 6.9 bar
Maximum probe shock:	10 G
Conductivity sense range:	> .78 $\mu$ S
Min. detectable hydrocarbon thickness:	.0312" / <.8 mm

### Tape

Material:	Kynar® coated Stainless Steel
Length/Weight:	100' / 30 m 7.7 lbs (3.5 kg) w/case 15.2 lbs (6.9 kg)
Accuracy:	100 <sup>th</sup> of a foot/100' (3 mm/30 m) Per Federal Specification GGG-T-106E

**Reel/Frame**

Size:	100'/30m	13" L x 12" W x 3.25" High 33 cm L x 30.5 cm W x 8.3 cm High
	w/Case	20" L x 14" W x 8" High 50.8 cm L x 35.6 cm W x 20.3 cm High

**Unit**

Operating temperature range:	32°F / 0°C to 140°F / 60°C
Storage temperature range:	-40° / -40°C to 170°F / 75°C
Humidity:	5-95% non-condensing
Battery:	9 VDC (Six, Duracell Type MN1500 size AA)
Self shut off time:	4 minutes
Output tone (hydrocarbons):	500 Hz typ
Output modulation tone (water):	3.5 Hz typ

**Section 7: System Schematic**

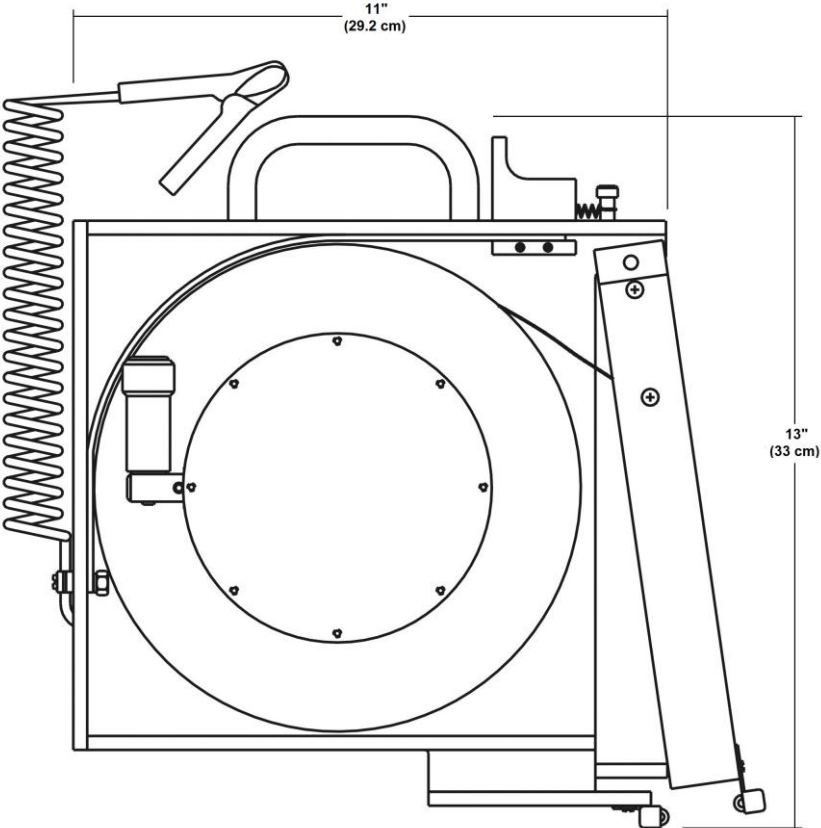

## Section 8: Replacement Parts List

### Small Diameter Interface Probe

Parts Description	Parts List
METER,INTERFACE,SM ORS IP,100' WITH CASE	86050001
METER,INTERFACE,SM ORS IP,30M WITH CASE	86050004
METER,INTERFACE,SM ORS IP,100' NO CASE	86050007
METER,INTERFACE,SM ORS IP,30M NO CASE	86050010
ASSY,TAPE,ORS IP,SM DIA,100'	56050006
ASSY,TAPE,SMALL ORS IP,30M	56050009
ASSY,PROBE,ORS IP,SM DIAM	56050002

### Large Diameter Interface Probe

Parts Description	Parts List
INTERFACE PROBE,100' ENGRG WITH CASE	1068013
INTERFACE PROBE,30M,METRIC WITH CASE	1068017
INTERFACE PROBE ASSY,100'	2068009
INTERFACE PROBE ASSY,30 METER	2068013
ASSY,TAPE,ORS IP,LG DIA,100'	3068002
ASSY,TAPE,ORS IP,LG DIA,30M	3068012
PROBE ELEX/REM PRISM ASSY	2068004
PRISM ASSY,REMOVABLE	2060010

### Large Diameter Chemical Interface Probe

Parts Description	Parts List
INTERFACE PROBE,100' CHEMICAL WITH CASE	1068016
INTERFACE PROBE ASSY,100'CHEM	2068049
ASSY,TAPE,ORS IP,LG DIA,100', CHEMICAL	56050017
ASSY,TAPE,ORS IP,LG DIA,30M, CHEMICAL	56050018
PROBE ELEX/PSM ASSY,CHEM	2068022
PRISM,PYREX,CHEM IP	ORS643007
GUARD POST,SS,#2-56	ORS732001

## Additional Accessories

Parts Description	Parts List
CASE,CARRYING,100'IP WITH FOAM GUIDE,TAPE,PVC	PPM132002 22050601
ASSY,WIPER,RIGHT,COATED	2060001
ASSY,WIPER,LEFT,COATED	2060002
HANDLE,CRANK ASSEMBLY	2060004
ASSY,GROUNDING CLIP,IP	2060008
PROBE HOUSING LATCH ASSY	2060012
BATTERY,1.5V,SIZE AA,EACH	PPE041006
BATTERY,CLIP HOLDER,6 AA	PPE042006

(the following parts require electrical experience soldering skills to replace)

FACEPLATE/REEL PCB ASSY:W/O FM	2068015
ASSY,BATTERY SNAP,POTTED	2068038-00
MANUAL,IP,W/ORS STYLE FRAME	16050017

## Appendix A – Tripod Mount and Tape Guide

### Interface Probe Tripod Mount

The Interface Probe is equipped with a 1/4-20 threaded hole (located on the bottom of the frame assembly) for mounting on a standard photo or video tripod. This feature allows the probe to be centered in the well and prevents the probe or measuring tape from sustaining damage during deployment or recovery.



Example of Interface Probe Assembly mounted to tripod

## Tape Guide

A Tape Guide (shown below) is also available (see Section 8) which can easily be placed onto the rim of a well head. The tape guide allows the Interface Probe tape to smoothly deploy into the well without having the tape catch or lay upon any sharp edges.

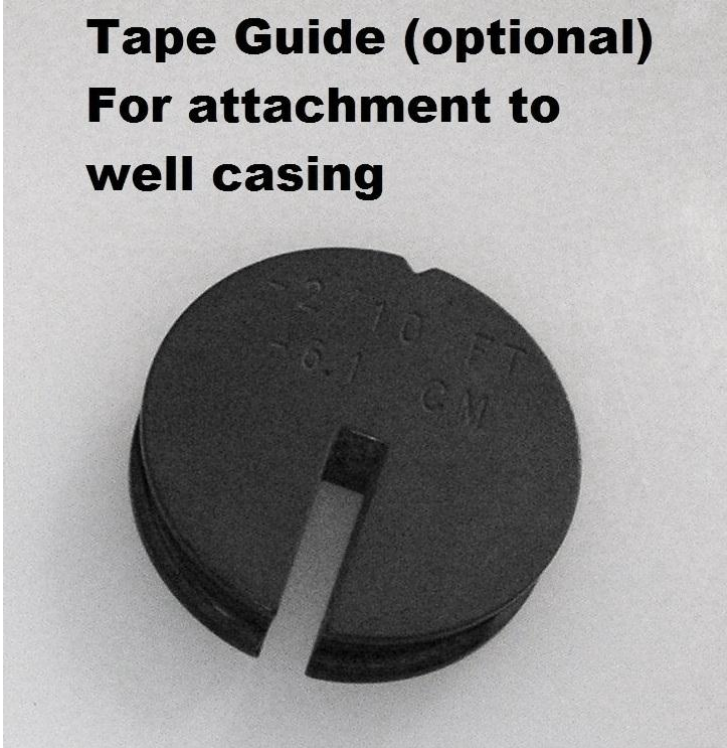

## **Appendix B – Chemicals and Decontamination**

### **CHEMICAL RESISTANCE CHART**

The compatibility of the Interface Probe with various chemicals is listed in the table on the following pages. For chemicals not listed, please consult the factory.

Chemical resistance is rated as follows:

A - Good: at 20 degrees C.

B - Fair: Slight attack and absorption. Inspect and rinse after use.

C - Poor: Use the Geotech Large Diameter Chemical Interface Probe.

\* Indicates that the probe material has not yet been tested specifically with that chemical but the results can be predicted from tests with similar chemicals.

A summary of the resistance of the sensing head to water, organic chemicals is given below.

#### **WATER**

The probe is not attacked chemically by water.

#### **INORGANIC CHEMICALS**

The probe is unaffected by most inorganic reagents. Aqueous solutions do not generally damage the prism, although it may be temporarily softened by absorbed water. The prism is attacked by concentrated oxidizing mineral acids (nitric, sulfuric, and hydrochloric) at room temperature but is not affected by more dilute acids. Resistance to alkalis is good.

#### **ORGANIC CHEMICALS**

In general, aliphatic hydrocarbons, alcohols, benzene, petroleum spirits, aliphatic organic acids, oils and fats do not attack the prism. Slight absorption may occur but does not usually cause degradation. The prism is attacked by highly polar organic solvents such as dimethylsulphoxide, aromatic amines, nitrobenzene, and certain chlorinated hydrocarbons such as dichloromethane and chloroform.



<b>Chemical</b>	<b>Results</b>	<b>Chemical</b>	<b>Results</b>
Acetaldehyde	C	Detergent Solutions	A
Acetic Acid-glacial	A	Dibutyl phthalate	A
Acetic Acid-10%	A	Dichlorobenze	C
Acetone	C	Dichloroethane	C
Aluminum Salts	A*	Dichloroethelyne	B
Ammonia- 880	A	Diesel Oil	A
Ammonium hydroxide-10%	A	Diethylamine	A
Ammonium chloride-10%	A	Dimethyl Formamide	C
Amyl Acetate	B	Diocetyl phthalate	A
Aniline	C	Dioxane	B*
"Arcton" propellants	A*	Edible fats & oils	A
Aviation hydraulic fluid	B	Ethanol	A
Aviation spirit	A	Ethyl Acetate	C
Barium Salts	A*	Ethyl Alcohol	A
Benzaldehyde	C	Ethylene glycol	A
Benzene	A	Ferric chloride	A
Benzoic Acid	A	Formaldehyde	A
Benzen Sulfonic Acid	A*	Formic Acid	A
Bleach	A	Gasoline (premium)	A
Boric Acid	A*	Glycerol	A
Brake Fluid	B	Heptane	A
Brine	A	Hexane	A
Butane	A	Hydrochloric acid-10%	A
Butanol	A	Hydrochloric acid (conc.)	A
Butyl Acetate	B*	Hydrogen Peroxide	A
Calcium nitrate	A	Hydrogen sulfide	A
Calcium hypochlorite	A	Iodine	B
Carbon disulphide	B*	Isopropanol	B
Carbon tetrachloride	A	Iso-octane	A
Chlorine	C	Kerosene	A
Chlorobenzene	C	Lactic Acid	A*
Chloroform	C	Lead Acetate	A*
Chlorosulfonic acid	C*	Linseed Oil	A
Chromic Acid	A	Magnesium Sulfate	A
Citric Acid	A	Mercuric chloride	A*
Cooking oil	A	Mercurous chloride	A*
Copper sulfate	A	Mercury	A*

<b>Chemical</b>	<b>Results</b>
Nickel Salts	A*
Nitric Acid-10%	A
Nitric Acid (conc.)	C
Nitrobenzene	C
Oils (Vegetable)	A
Oleic acid	A*
Oleum	C
Oxalic acid	A
Perchloroethylene	C
Petrol	A
Petroleum Ether	A
Phenols	C
Potassium hydroxide-10%	A
Potassium hydroxide-50%	A
Propane	A*
Pyridine	C
Silicon fluids	A
Silver nitrate	A
Soap solution	A
Sodium chloride	A
Sodium hydroxide-10%	A
Sodium hydroxide-50%	A
Sodium hypochloride	A*
Sulfur dioxide	B
Sulfuric Acid-10%	A
Sulfuric acid (conc.)	C
Sulfurous acid	C*
Tar	A*
Tartaric acid	A*
Tetrahydrofuran	C
Toluene	C
Transformer oil	A
Trichloroethylene	B
Turpentine	A
Vaseline	A*
Varnish	A
Water	A
Wax	A*
White spirit	A
Wines and spirits	A*
Xylene	B
Zinc salts	A*

**Some common decontamination solutions are listed below along with the contaminants they are effective against:**

<b>Solution</b>	<b>Effective Against</b>
Water	Short-chain hydrocarbons, inorganic compounds, salts, some organic acids, other polar compounds.
Dilute Acids	Basic (caustic or alkaline) compounds, amines, hydrazines.
Dilute Bases	Acidic compounds, phenols thiols, some nitro-and sulfonic compounds.
Organic solvents	Nonpolar compounds (such as some organic compounds)

The use of organic solvents is not recommended because:

- Organic solvents can permeate and/or degrade the protective clothing and,
- They are generally toxic and may result in unnecessary employee exposure to hazardous chemicals.

When in doubt, use a dish washing liquid detergent. As a decontamination solution, it is readily available, is the safest of all the above, and is usually strong enough if used generously. The use of steam can also be effective for decontamination. A water-lazer (pressurized water) is exceptionally valuable.

The following substances are noted for their particular efficiency in removing certain contaminants or for decontaminating certain types of equipment.

<b>Solution</b>	<b>Effective Against</b>
Penetone	PCB Contamination (since penetone may also remove paint, it is a good idea to spot-test before use)
Liquinox	Contaminated pumps
Ivory liquid	Oils
Diluted HTH	Cyanides
Radiac	Low level radioactivity
Isopropanol	Biological agents (should not be used on rubber products since it will break down rubber)
Hexane	Certain types of lab or sampling equipment (use of hexane is discouraged due to its flammability and toxicity)
Zep	General purpose cleaning
Alconox	General purpose cleaning

## **Recommended Supplies for Decontamination of Personnel, Clothing and Equipment**

The list below contains recommendations for supplies that should be on hand for the decontamination of personnel, clothing and equipment. Depending on the site activities, not all of these items may be needed. Alternatively, some additional items not listed here may be required.

- Drop cloths of plastic or other suitable material, such as visqueen, for heavily contaminated equipment.
- Disposal collection containers, such as drums or suitably lined trash cans for disposable clothing and heavily contaminated personal protective clothing or equipment to be discarded.
- Lined box with adsorbent for wiping or rinsing off gross contaminants and liquid contaminants.
- Wash tubs of sufficient size to enable workers to place booted foot in and wash off contaminants (without a drain or with a drain connected to a collection tank or appropriate treatment system).
- Rinse tubs of sufficient size to enable workers to place booted foot in and wash off contaminants (without a drain or with a drain connected to a collection tank or appropriate treatment system)
- Wash solutions selected to wash off and reduce the hazards associated with the contaminated wash and rinse solutions.
- Rinse solution (usually water) to remove contaminants and contaminated wash solutions
- Long-handled, soft-bristled brushes to help wash and rinse off contaminants.
- Lockers and cabinets for storage of decontaminated clothing and equipment.
- Storage containers for contaminated wash and rinse solutions.
- Plastic sheeting, sealed pads with drains, or other appropriate method for containing and collecting contaminated wash and rinse water spilled during decontamination.
- Shower facilities for full body wash or at a minimum, personal wash sinks (with drains connected to a collection tank or appropriate treatment system).
- Soap or wash solution, wash cloths and towels.
- Clean clothing and personal item storage lockers and/or closets.

## **Decontamination Solutions to Avoid**

Some decontamination solutions should be avoided because of their toxicity, flammability, or harmful effects to the environment.

Halogenated hydrocarbons, such as carbon tetrachloride, should not be used because of their toxicity, possible incompatibility, and some because of their flammability.

Organic decontamination solutions should not be used on personal protective equipment (PPE) because they may degrade the rubber or other materials comprising the PPE.

Mercurials are sometimes used for sterilization. They should be avoided because of their toxicity.

Chemical leaching, polymerization, and halogen stripping should be avoided because of possible complications during decontamination.

Sand-blasting, a method of physical removal, should be avoided because the sand used on the contaminated object usually needs to be disposed of as hazardous waste, a very costly proposition. Sand-blasting will also expose personnel to silica, a carcinogen.

Freon is known to be particularly effective for the cleansing of PCB's but its effect on the ozone layer is extremely harmful. Its use is discouraged.

Strong acids or bases should not be used when cleaning metals, gaskets, tools or other equipment because of the possibility of corrosion.

## **Disposal of Decontamination Solutions and Waste Water**

All solutions and water used for decontamination must be collected. If lab analysis indicates that the water and/or solutions exceed allowable contamination levels, they must be treated as hazardous waste. Alternatively, the solutions and water may be treated on-site to lower the contamination levels and render them non-hazardous.

Containers such as 55-gallon drums should be available for storage of wastes.

Spent decontamination solutions can be collected by using heavy-duty plastic sheets, visqueen sheets, kiddie pools, or if needed, a larger containment basin. The decontamination of equipment must be performed on the sheets or in the basins. They could be placed on a slight angle so that the spent decontamination solutions drain into a collection basin or drum.

## The Warranty

For a period of one (1) year from date of first sale, product is warranted to be free from defects in materials and workmanship. Geotech agrees to repair or replace, at Geotech's option, the portion proving defective, or at our option to refund the purchase price thereof. Geotech will have no warranty obligation if the product is subjected to abnormal operating conditions, accident, abuse, misuse, unauthorized modification, alteration, repair, or replacement of wear parts. User assumes all other risk, if any, including the risk of injury, loss, or damage, direct or consequential, arising out of the use, misuse, or inability to use this product. User agrees to use, maintain and install product in accordance with recommendations and instructions. User is responsible for transportation charges connected to the repair or replacement of product under this warranty.

## Equipment Return Policy

A Return Material Authorization number (RMA #) is required prior to return of any equipment to our facilities, please call our 800 number for appropriate location. An RMA # will be issued upon receipt of your request to return equipment, which should include reasons for the return. Your return shipment to us must have this RMA # clearly marked on the outside of the package. Proof of date of purchase is required for processing of all warranty requests.

This policy applies to both equipment sales and repair orders.

FOR A RETURN MATERIAL AUTHORIZATION, PLEASE CALL OUR  
SERVICE DEPARTMENT AT 1-800-833-7958.

Model Number: \_\_\_\_\_

Serial Number: \_\_\_\_\_

Date of Purchase: \_\_\_\_\_

## Equipment Decontamination

Prior to return, all equipment must be thoroughly cleaned and decontaminated. Please make note on RMA form, the use of equipment, contaminants equipment was exposed to, and decontamination solutions/methods used. Geotech reserves the right to refuse any equipment not properly decontaminated. Geotech may also choose to decontaminate the equipment for a fee, which will be applied to the repair order invoice.



**Geotech Environmental Equipment, Inc.**  
2650 East 40th Avenue Denver, Colorado 80205  
(303) 320-4764 • **(800) 833-7958** • FAX (303) 322-7242  
email: [sales@geotechenv.com](mailto:sales@geotechenv.com) website: [www.geotechenv.com](http://www.geotechenv.com)