

# SPY® MODEL 780 PORTABLE DC HOLIDAY DETECTOR OPERATING INSTRUCTIONS



# WELCOME

Thank you for purchasing the SPY® Model 780 DC Holiday Detector.

Pipeline Inspection Company and our SPY® brand of coating inspection, jeep meter and pig tracking equipment has been serving companies all over the world since 1953. With the purchase of this high precision instrument you can now enjoy access to worldwide service and support only SPY® and our vast Distributor network can offer.

For more information about SPY® brand equipment please visit our website at [www.picltd.com](http://www.picltd.com).



The SPY® Model 780 DC Holiday Detector meets the Electromagnetic Compatibility Directive and the Low Voltage Directive. This product is a Class A, Group 1 ISM equipment according to CISPR 11. Group 1 ISM product: A product in which there is intentionally generated and/or used conductively coupled radio-frequency energy which is necessary for the internal functioning of the equipment itself. Class A products are suitable for use in all establishments other than domestic and those directly connected to a low voltage power supply network which supplies buildings used for domestic purpose.

**SPY** is a registered trademark of Pipeline Inspection Company, Houston, Texas 77055, United States.

A copy of this Operating Instructions Manual can be downloaded on our website at [www.picltd.com](http://www.picltd.com).

# TABLE OF CONTENTS

Operator Safety . . . . .	4
Unit Calibration . . . . .	6
Principles of Holiday Detector Operation . . . . .	7
SPY® Model 780 DC Holiday Detector Overview . . . . .	8
Connecting Accessories . . . . .	10
Controls and Voltage Adjustments . . . . .	12
DC Paddle . . . . .	14
Field Calibration . . . . .	15
Battery Charging and Storage Instructions . . . . .	16
Troubleshooting Guide . . . . .	18
Technical Specifications . . . . .	19
Maintenance and Repair . . . . .	20
Warranty . . . . .	21
Electrode Types . . . . .	22
Accessories . . . . .	23
Related Equipment . . . . .	24

# OPERATOR SAFETY

## PLEASE READ THESE INSTRUCTIONS CAREFULLY PRIOR TO USING THE EQUIPMENT!

 **WARNING!** This is a HIGH VOLTAGE device capable of producing an electrical shock if not properly grounded and/or operated in accordance with instructions and procedures prescribed in this manual! If you have a pacemaker or other life critical electronic medical device DO NOT use this device.

Only trained and responsible personnel should operate high voltage equipment. Display warning labels prominently prior to and during testing. Portable holiday detectors are designed to operate and maintain an electric current output well below levels which could cause injury. However, you may experience a mild shock if the test electrode or ground is touched while the equipment is activated. Wear rubber or plastic gloves and non-conductive footwear to minimize potential shock. Keep in mind that the shock prevention effectiveness of the rubber or plastic glove and footwear is limited to the condition of their protective surface. Make sure your gloves and footwear are void of tears and holes and are in good condition.



Use of Portable Holiday Detectors is limited to finding defects in insulating materials. Testing should be conducted clear of personnel not involved in the testing procedure. Personnel operating Portable Holiday Detectors should be aware of the safety limitations imposed by their environment at all times. Operator should have an assistant to ensure that unauthorized personnel are kept clear of the testing area.

 **DANGER!** Portable Holiday Detectors create an arc or spark. Use of a Portable Holiday Detector in or around combustible or flammable environments can result in an explosion. When operating in any potentially hazardous area, consult with the plant or site safety officer before proceeding with a holiday detection test in any potentially hazardous or suspect area.



 **DANGER!** If you have a pacemaker **DO NOT** use this device.

 **DO NOT CUT** the ground cable to a shorter length.

 **CAUTION! DO NOT TOUCH** the bare ground wire when the detector is turned on.

  **WARNING! DO NOT USE WHEN RAINING.** If it is raining then there is a safety concern for the operator. Pure water is non-conductive, but almost any contaminant will cause water to become conductive (dust in the air, salt from an operator's hands). If this conductive water covers the wand (black plastic part of the detector where the electrode is attached) and the orange case then then the operator will become the return path for the high voltage. While this is NOT LETHAL, it does hurt. Also the unit may become damaged.

 If it isn't raining, but the coating surface is wet, the problem becomes one of accurately locating the coating defect (holiday). Again, the water will conduct the electricity and you may get false holiday indications many feet from the actual holiday(s). In this case it is recommended that you dry the testing area prior to inspection.

  **CAUTION! DON'T USE AROUND SENSITIVE ELECTRONICS OR RADIO EQUIPMENT.** When in standby the SPY® Model 780 DC Holiday Detector will generate radio frequency emissions which are within the limit defined by the Electromagnetic Compatibility Directive. Due to its method of operation however, the SPY® Model 780 DC Holiday Detector will generate broadband RF emissions when the unit is generating high voltage or when a spark is produced at the electrode. It is therefore recommended that the user does not activate the high voltage within the vicinity of sensitive electronics or radio equipment.

**ELECTRODES/ACCESSORIES:** It is imperative for the accurate operation of unit that electrodes (Spring & Brush) and accessory attachments (Spring & Brush Wands & Ground Cable) be kept clean and free of dirt and debris. Please clean with a damp cloth before storing them for future use.

## UNIT CALIBRATION

As the operator of this unit you require accurate, safe, and reliable equipment to perform coating inspections at the proper output voltage.

Prior to leaving our manufacturing facility Pipeline Inspection Co. certifies that SPY® Model 780 Holiday Detector has been calibrated and demonstrates the output voltage, which appears on the display of the detector within +/- 5% of indicated setting over the range of 1000 - 5000 volts. Since output voltage is regulated, this tolerance is maintained regardless of load.

Your unit comes with a **Factory Calibration Certificate** and a **Factory Authorized Calibration Decal** applied to the side of the unit both with the date your unit was calibrated.

Our units do not tend to drift but it is recommended that this unit be calibrated at least once per year or more frequently based on heavy usage. **Recalibration of our equipment should be performed ONLY at a SPY® Authorized Service Center due to the unique calibration process; test equipment utilized and properly trained SPY® technicians.**

We DO NOT recommend using any other calibration service other than a SPY® Authorized Service Center; using an outside service with technicians not trained to work on SPY® brand equipment could damage the unit and if the enclosure is opened will void the warranty.

When calibration is needed please return your unit to a SPY® Authorized Service Center or SPY® manufacturing facility located at:

Pipeline Inspection Company  
Attn: Calibration  
1919 Antoine Dr.  
Houston, TX 77055

Please include: Company Name and Contact info. For a complete list of Authorized Service Centers please visit our website at [www.picltd.com](http://www.picltd.com). If a copy of the Calibration Certificate on file is needed it may be obtained by emailing a request to [sales@picltd.com](mailto:sales@picltd.com).

## PRINCIPLES OF HOLIDAY DETECTOR OPERATION

Holiday detectors are devices that are used to detect the presence of defects in the non-conductive coatings applied to surfaces in order to minimize ion flow from a conductive substrate. This is accomplished by attempting to create an electrical circuit by passing an electrode over the non-conductive coating. A sufficient voltage is generated in the electrode to cause a spark that will jump from the electrode to the substrate if a defect is found. When a defect is found a horn will sound and a LED light will turn off.

Metal objects such as pipelines, reinforcing bar (rebar), storage tanks or structural steel are normally covered with a protective coating to prevent corrosion. Holiday detectors are used to inspect these coatings for pin holes, scratches or other coating faults. They work by generating a voltage high enough to jump a gap that is longer than the thickness of the coating.

The laws of physics determine the required voltage level to jump a given distance, or gap. Coating type also affects voltage level requirements. Environmental Conditions such as humidity, temperature, and other environmental factors will also affect voltage required to jump a given distance.

A holiday detector simply applies a voltage to the outside of the coating. With the pipe connected to ground and with the holiday detector connected to ground, a hole in the coating will allow a spark to jump or "arc" from the electrode to the pipe to complete the circuit. When a complete circuit is formed, an audible and visual signal is activated on the holiday detector.

# SPY® MODEL 780 DC HOLIDAY DETECTOR OVERVIEW

The Model 780 DC Holiday Detector is a low voltage (1-5kv) detector designed specifically for thin film epoxy coatings. The output voltage of this detector is normally D.C. (direct current). However, if light moisture is encountered on the pipe, the detector output starts to fast pulse. Fast pulse enables continued operation whereas with older type thin film detectors the operator either had to wait until the moisture evaporated or the pipe had to be dried.

The Model 780 DC Holiday Detector incorporates circuitry allowing the detectors to maintain a selected voltage, regardless of different pipe diameters, coating thickness variations and battery wear (unless the battery is totally discharged). Keep in mind that the voltage can decrease slightly depending on ground losses and/or conditions.

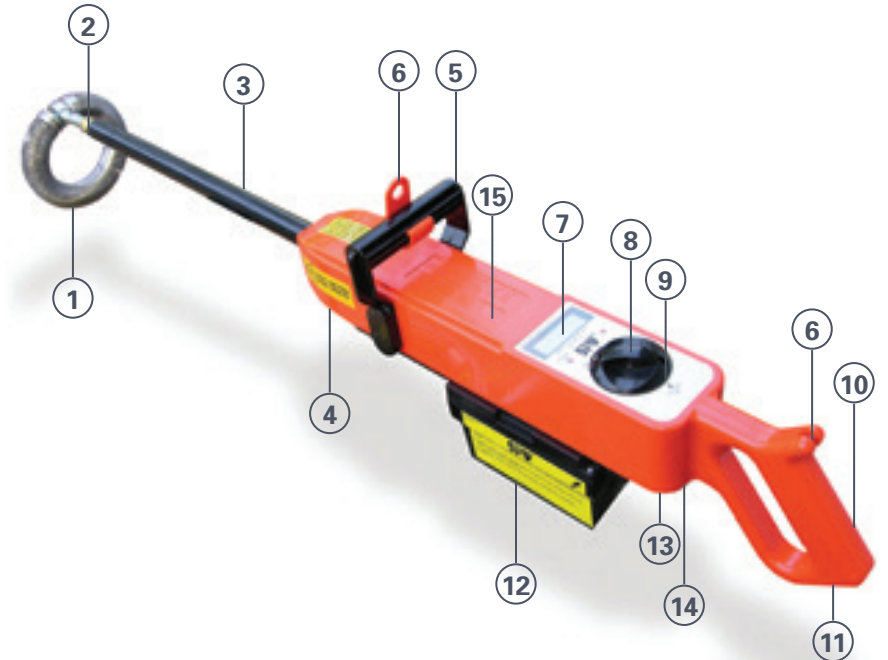

- |   |  |    |  |
|---|--|----|--|
| 1 | Spring or Brush Electrode                      | 8  | Control Knob (3 positions: Off / Voltage Set / On) |
| 2 | Electrode Accessory Connection Point           | 9  | Voltage Set Access Hole                            |
| 3 | Electrode Wand                                 | 10 | Comfort Grip                                       |
| 4 | Wand Release                                   | 11 | Ground Cable Connection Point                      |
| 5 | Easy Carry Top Handle                          | 12 | 8 Hour Battery                                     |
| 6 | Shoulder Strap Connection                      | 13 | Quick Release Battery Button                       |
| 7 | Built In Digital LCD Jeepmeter (Voltage meter) | 14 | Horn   |
|   |  | 15 | Model & Serial Number                              |

# CONNECTING ACCESSORIES

**CAUTION! DO NOT TOUCH** Make sure the switch is in the OFF position prior to connecting any accessory.

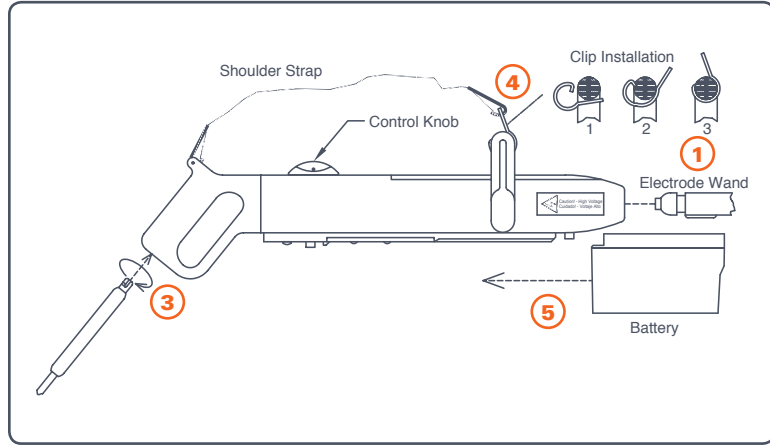

**STEP 1. CONNECTING THE ELECTRODE WAND.** Plug into “front” of the detector. Push the wand in until it locks in place. It can be released by pressing the release (located near the front / bottom of the unit) upwards until the wand pops out.

**STEP 2. CONNECTING THE ELECTRODES.** Connect the electrode to the wand. The wand comes with the spring adapter attached to the wand. If spring or full circle brush electrode attach to pipe.

**CAUTION! DO NOT TOUCH** THE ELECTRODE WHILE THE DETECTOR IS OPERATING.

**OPTIONAL: BRUSH ADAPTER KIT.** The Model 780 Kit comes with a brush adapter kit for use in connecting flat brush/neoprene electrodes, half circle electrodes and full circle electrodes.

**STEP 3. CONNECTING THE GROUND CABLE.** The ground cable plugs into the bottom side of the rear handle. It uses a quarter turn fastener, so insert the cable as far as possible, and then rotate it at least a quarter clockwise turn until it locks in place.

**PROPER GROUNDING.** Make sure the ground cable is uncoiled and extended.

**DIAGRAM 1:** Shows the method when the pipe is on wood skids or hanging from pipe slings; attach the holiday detector ground cable directly to the uncoated substrate (pipe cutback) with a clamp to complete the circuit.

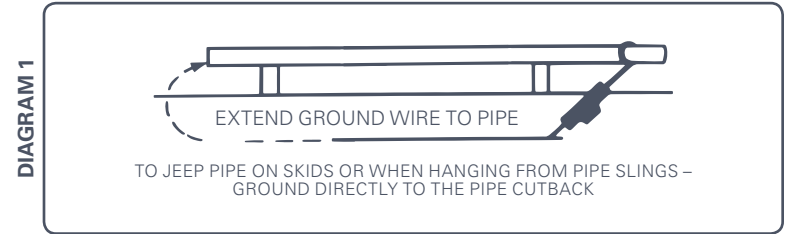

**CAUTION! DO NOT TOUCH** THE GROUND WIRE WHILE DETECTOR IS OPERATING.

**DIAGRAM 2:** Shows the method of attaching a grounding cable from a grounding rod (earth ground) to the pipe cutback (substrate). Next attach the holiday detector ground cable to the second grounding rod (earth ground) to complete the circuit.

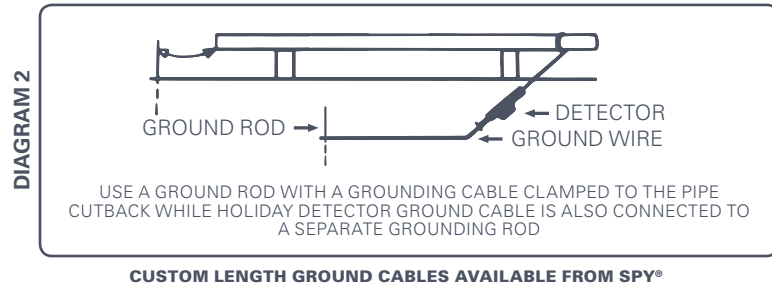

**STEP 4. CONNECTING THE CLIP\SHOULDER STRAP.** First attach strap clip on the black handle by placing the tab portion of the strap clip into the top groove on the back side of the handle that faces the unit display. Then push up on the bottom of the strap clip in the direction of the opposite side of the black handle until the strap clip snaps into place around the black handle. Next attach the shoulder strap to the front handle clip and the pin on top of the rear handle. The front clip can slide to the left or right on the handle to allow hand placement while using the detector.

**STEP 5. BATTERY.** The battery will only install one way (from the front side). It is keyed to prevent insertion in an incorrect fashion. One end of the battery is flat and the other has a step. The flat end goes towards the rear of the unit. Push the battery on until it snaps in place (the spring will be almost completely compressed when properly installed). To remove the battery, press the orange release on the bottom left side of the unit. Newer batteries can be a bit resistant when trying to remove the battery because of the newness of the battery and the tight fit on the slide path; if so give a gentle tap with your palm on the battery in the direction of removal.

## CONTROLS AND VOLTAGE ADJUSTMENTS

The control knob has three positions: OFF, VOLTAGE SET, and ON. In the OFF position all power is off, including the high voltage output.

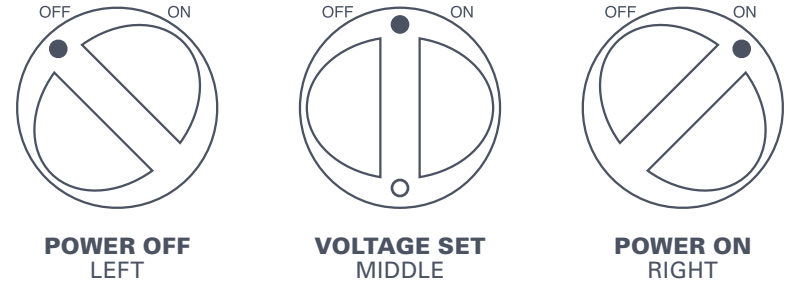

**STEP 6. SETTING THE VOLTAGE OUTPUT.** Turn the knob clockwise to the middle position (voltage set) this turns on the high voltage output and activates the internal Jeepmeter (voltage meter), the LCD display turns on, the red LED light will blink and the horn tone will pulse on and off.

Using the SPY® provided flathead screwdriver place the **flat screwdriver head through the hole on the bottom side of the knob to change the voltage setting**, the voltage (shown on display) is in kilovolts (thousands of volts.). Turning the screwdriver clockwise will increase the voltage and counter clockwise will decrease the voltage.

**NOTE:** Voltage setting can only be viewed in the middle set position. This is to prevent confusion during detection of holidays as the voltage will drop when the unit discharges to substrate. Static electricity on protective coatings can be picked up and can cause fluctuations in Voltage reading.

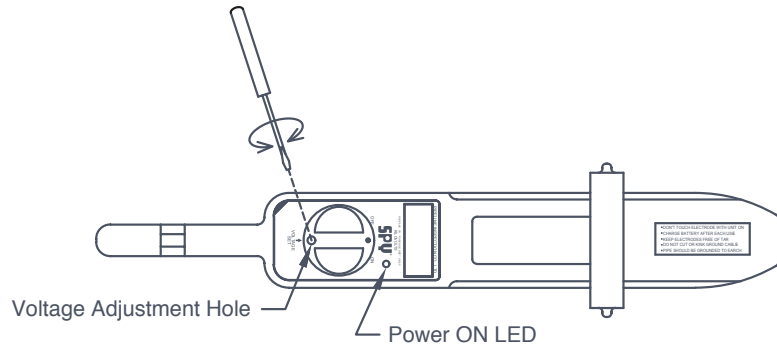

**STEP 7. TURNING ON UNIT FOR HOLIDAY DETECTION.** Turn the unit clockwise to the ON position. In this position the unit is in the normal running mode with the red LED on steady, the horn tone will be steady, and the display will turn off.

## DC PADDLE

The Model 780 DC Holiday Detector comes with a DC Paddle to assist in the location of Holidays (defects in the coating). Due to the low voltage of the Model 780 DC Holiday Detector the spark that jumps the gap from the electrode to the substrate when a holiday (defect in the coating) is found can sometimes be hard to see as opposed to using a higher voltage detector which produces a larger brighter spark. The DC Paddle acts as an extension of the spring electrode giving the user a wider path to test areas the user suspects are producing the holiday but can't see during standard detecting travel speed.

Immediately after holiday detector indicates a fault, roll spring electrode back approximately 2-3 inches. Place the edge of the conductive rubber paddle against the spring and wipe the paddle around the entire circumference of the pipe until detector signal activates indicating the exact location of the coating flaw.

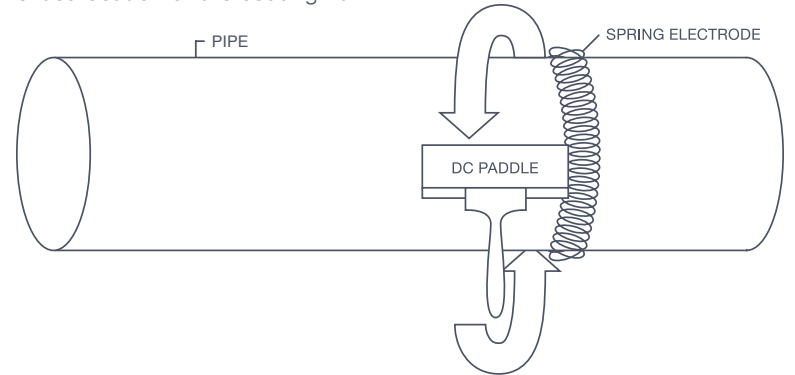



# FIELD CALIBRATION INSTRUCTIONS

Prior to each use of the Model 780 DC Holiday Detector it is important to perform a Field Calibration to verify that the required voltage setting for the coating thickness will accurately detect defects (Holidays) in the coating. There are two methods to performing a Field Calibration:

## METHOD 1: ADDING TEST DEFECTS TO THE COATING.

1. Prior to turning on and setting the voltage on the detector manually add one pinhole size defect on the coating surface, make sure the defect goes down to the substrate (bare metal).
2. Set the voltage on the detector to the minimum voltage based on the coating thickness  $525 \times \text{sqrt}(\text{mils})$  and using the spring or brush electrode travel over the test defects.
3. If you see the spark jump the gap from the electrode to the substrate in the defect and the horn on the detector changes from a running tone to a loud signal horn and the light on the detector turns off then you have successfully detected defects (holidays) in the coating and verified the detector operation.
4. If your test does not successfully detect the test defect then increase the voltage by 10% and test again. If test fails again continue increasing by 10% until test is successful.

## METHOD 2: USING THE BARE METAL END OF THE TEST SURFACE.

1. Roll the spring or brush electrode toward the bare metal end of the pipe. When the electrode is sufficiently close to the bare metal, a spark will jump from the electrode to the pipe, the running tone will change to a loud signal horn will sound and the light on the detector display will go out to designate a holiday. Of course it is not a real holiday but it demonstrates what happens when the electrode encounters a holiday and verifies correct detector operation.
2. If your test does not successfully detect the test defects then first verify the voltage setting is accurate for the surface coating.

# BATTERY CHARGING AND STORAGE INSTRUCTIONS

The SPY® battery is a completely sealed, rechargeable 12 volt unit. It can be used in any position and under most conditions. Batteries are shipped fully charged however prior to use we recommend you place them on the charger to verify charge level is full.



**CAUTION!** Make sure the switch is in the OFF position prior to removing the battery.

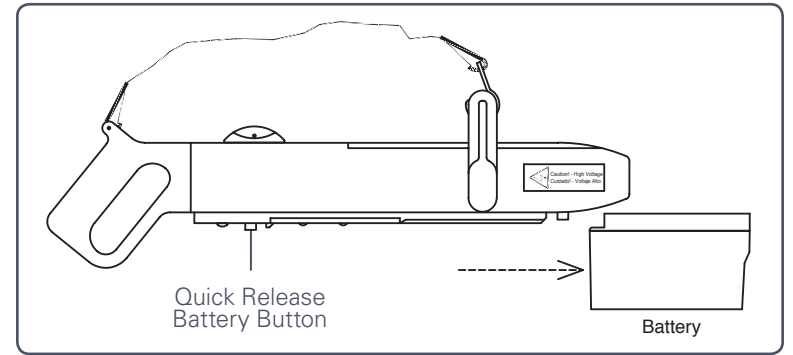

**BATTERY REMOVAL.** Press the release (orange part) on the base plate (black part) and push the battery away from the rear handle. Newer batteries can be a bit resistant when trying to remove the battery because of the newness of the battery and the tight fit on the slide path; if so give a gentle tap with your palm on the battery in the direction of removal.

**WARNING!** Do not use any other type of charger. This charger is specifically designed for this battery.

**CHARGING THE BATTERY.** Slide the charger onto the battery as far as possible. A discharged battery requires 8-20 hours to fully charge.

There is no danger of overcharging the battery. After the battery is fully charged, the charger will maintain a trickle charge to keep the battery at peak charge.

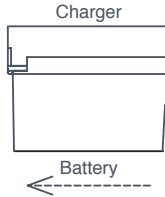

It is recommended that the battery be charged for 8 hours after each use. After heavy usage charge the battery for 20 hours.

Do not disconnect the charge power cord while the battery is attached.

**BATTERY STORAGE.** The battery should be fully charged BEFORE storing. Storage at temperatures below 75°F is recommended. After six months of storage or storage in extremely high temperatures, the battery should be recharged to maintain peak efficiency and maximize its life span.

**IMPORTANT!** Contacts on the battery, charger and the detector must be kept clean and bright to assure good connection!

**BATTERY DISPOSAL.** The battery pack is a sealed non-replaceable lead acid battery, when the battery pack no longer good it must be recycled.



## TROUBLESHOOTING GUIDE

PROBLEM	POSSIBLE SOLUTION	CORRECTION METHOD
<b>HOLIDAY DETECTOR WILL NOT DETECT HOLIDAYS</b>	Field Calibration	Perform a field calibration to compensate for environmental factors (see page 16). Use NACE equation to set min voltage. Travel over known holiday. Turn up voltage and repeat until holiday is detected. (Note: Max voltage is determined by the coating manufacture, typical values for new coating range from 400 to 1000 Volts/mil).
	Detection Testing	Touch electrode/wand directly to bare ground cable to test that the unit is functioning properly. A spark will appear and the horn will sound if switch is in the "ON" position.  If it does not detect then ensure ground cable and electrode wand are correctly inserted using steps 4 and 5 above.  If unit still fails to detect a direct short repair may be needed, Call Pipeline Inspection Company for support.
	Minimum Voltage Setting	Follow NACE standard SP0490-2007: Section 3.
	Check Detector Ground Connection	With the detector OFF remove the ground cable and fully reinsert it twisting 90 degree until locked. Ensure the opposite end is clean and well connected to the pipe or earth ground.
Check Electrode/Wand Connection	With the detector OFF remove the wand and fully reinsert until it locks into place. Ensure wand and electrode connection points are clean.	

TROUBLESHOOTING GUIDE CONTINUED ON THE NEXT PAGE...

# TROUBLESHOOTING GUIDE

PROBLEM	POSSIBLE SOLUTION	CORRECTION METHOD
<b>HOLIDAY DETECTOR WILL NOT DETECT HOLIDAYS</b>	Check Ground Connections	If pipe is connected to an earth grounding rod and the ground cable from the holiday detector is dragging the ground make sure all connections are clean (free of debris) and secure.
		If ground cable from the holiday detector is directly connected to the pipe cutback (substrate) make sure all connections are clean (free of debris) and secure.
		If the ground cable from the holiday detector and the earth grounding rod are both connected to a grounding collar make sure all connections are clean (free of debris) and secure.
	Adjust Travel Speed	Travel speed is important on Pulse units and must not be too fast or holidays could be missed. Follow NACE standard SP0274-2011 section 6.3: Make or find a holiday and attempt to detect at various speeds until reliable detection is obtained.
<b>HOLIDAY DETECTOR TURNS OFF WHILE IN-USE</b>	Charge/Replace Battery	The detector will automatically power down if the battery voltage drops below the required level. Ensure that the battery has been fully charged before use.
		Use a second battery that is charged and see if the detector still turns off.
	Test Battery	Additional testing may be needed conducted on the battery, see Battery Troubleshooting below.
<b>THE DETECTOR VOLTAGE NEEDS TO BE VERIFIED</b>	Use SPY JM or DCPJM	Do not use a regular multimeter as they will get damaged and are not rated for over 1,000 Volts. The SPY JM is rated for 7,000 Volts DC and 40,000 Volts Peak (crest) on pulse. The SPY DCPJM can measure up to 5,000 Volts DC.

# TROUBLESHOOTING GUIDE

PROBLEM	POSSIBLE SOLUTION	CORRECTION METHOD
<b>THE BATTERY DOESN'T SEEM TO BE WORKING WELL</b>	Check/Replace Battery	Use a multimeter to measure the battery voltage on the freshly charged battery. The voltage should read 13.0 Volts or higher if it just came off the charger. If it has been sitting for several hours the voltage can be as low as 12.3 Volts.
		If the voltage is lower than 12.0 Volts then the battery may have a problem and will probably need to be replaced. Test with a different charger if possible.
<b>PIPELINE ENGINEERS, INSPECTOR OR OWNER REQUIRE A SPECIFIC VOLTAGE FOR TESTING BUT HOLIDAYS ARE NOT BEING DETECTED</b>	Field Calibration	If the testing documentation on the pipeline requires a specific Voltage then that setting must be used. However environmental conditions such as humidity and temperature will affect the required voltage to spark across a specific gap size(holiday). For the holiday detector to create a spark or Jeep the voltage must be high enough to overcome the gap. If the voltage is set too low for the thickness, humidity and temperature then a spark will not occur. It is recommended to perform a field calibration every day or periodically as conditions change. See Field Calibration above
<b>THE PIPELINE NEEDS TO BE CHECKED BUT PIPE IS WET / IT IS RAINING</b>	Dry Pipe	Holiday detection cannot be done in the rain as it will conduct back to ground and give false holidays. Holiday detectors may be used with light moisture on the pipe however it is highly recommended that the pipe be dry and clean before testing. <b>Proper safety and safety equipment should be used when in wet conditions to prevent user from being shocked.</b>

## TECHNICAL SPECIFICATIONS

MODEL	780
Voltage Type	DC
Voltage Range (kV)	1-5 kV
Voltage Output Accuracy	±5%
Coating Range (Min-Max)	4-50 mils
Pulse Repetition Rate	N/A
Operating Temperature	-40°F to 148°F
Internal Volt Meter	YES – 1-5 kV
Display Type	LCD
Holiday Indicator Type	Audible/Visual
Power Type	12V Rechargeable Battery
Quick Release Battery*	YES
Battery charge time	Approx. 8 Hours
Unit Weight (w/ battery only)	7.45 lb
Unit Dimensions (w/o battery)	21.5" x 5" x 5.5" (L x W x H)
Unit Dimensions (w/ battery)	21.5" x 5" x 8" (L x W x H)
Domestic/International Standards Unit Complies With	CE, NACE SP0490-2007, NACE SP0188-2006, TM0186-2002

## MAINTENANCE AND REPAIR

If maintained the Model 780 DC Holiday Detector will offer you a lifetime of dependable operation. Regular care and maintenance of the unit is a requirement of good quality management practices.

**⚠ WARNING!** This detector does not contain any user-serviceable parts; your warranty will be voided if the SPY® unit is opened by anyone other than a SPY Authorized Service Center or SPY manufacturing facility.

In the event the unit fails to operate properly please return your unit to a SPY Authorized Service Center or SPY manufacturing facility located at:

Pipeline Inspection Company  
 Attention: Repair  
 1919 Antoine Dr.  
 Houston, Texas 77055

Please include: Company name, contact information and a short description of the problem with the unit. For a complete list of Authorized Service Centers please visit our website at [picltd.com](http://picltd.com).

### ELECTRODES AND ACCESSORIES

Springs and Brush electrodes and all attached accessories are prone to wear and tear and will eventually need to be replaced, timing of replacement will depend on how they are maintained and the coatings that they are used on.

## WARRANTY

Pipeline Inspection Company, hereafter referred to as (SPY®) warrants that SPY®, Model 780 Series Holiday Detectors shall, under normal use and service, be free from defects in material and workmanship. SPY®'s entire warranty obligation shall be limited to, at SPY®'s option, the repair or replacement free of charge to the buyer of any defective equipment or parts thereof which prove to be defective in material and workmanship under normal use and service.

Claims for defective parts must be made in writing within twelve (12) months after shipment of the equipment from the works of SPY®. Fast wearing and consumable parts including, but not limited to, electrodes and ground cables, are expressly excluded from the warranty. SPY® shall have the option to require return of a claimed defective part to SPY®'s manufacturing facility in the U.S.A., freight prepaid by buyer for examination to establish buyer's claim.

Except with SPY®'s prior written approval, SPY® shall not be liable (a) for the cost of repairs, alterations or replacements or any expense connected therewith made or incurred by the buyer or its designers, or (b) for defects resulting from alterations or repairs made by others than SPY®, or its approved representatives.

SPY® shall not be liable for damages, including but not limited to direct, special, indirect or consequential, resulting from the handling, or use, whether alone or in combination with other products, or any SPY® equipment or third party designed or manufactured equipment, including without limitation, any loss or damage sustained or caused by the operation and use of the equipment which is improperly operated or its successful operation is impaired by natural elements after its delivery to the buyer.

The foregoing warranty is exclusive and in lieu of all other warranties whether written, oral or implied (including without limitation, any warranty of merchantability or fitness for purpose).

## ELECTRODE TYPES

The Model 780 can be fitted with a wide variety of electrodes that vary in form, size and material to fit a wide range of coating inspection projects. If we don't carry it we can custom build an electrode to fit your project needs.



**FLAT BRUSH**  
(BRASS, STEEL  
OR NEOPRENE)  
1" - 72" (25-1829MM)



**FULL-CIRCLE  
STEEL SPRING**  
2" - 80" (50-2032MM)



**HALF-CIRCLE  
BRUSH (BRASS,  
STEEL OR  
NEOPRENE)**  
1" - 60" (25-1524MM)



**INTERNAL  
NEOPRENE  
1" - 64" (25-1625MM)  
OR SPONGE  
2" - 28" (50-711MM)**



**FULL-CIRCLE  
BRUSH (BRASS,  
STEEL OR  
NEOPRENE)**  
8" - 60" (203-1524MM)



**30'-100' INTERNAL  
PULL CABLE**

Please call our office at (713) 681-5837 or email us at [sales@picltd.com](mailto:sales@picltd.com) for more product details or to place an order.

## ACCESSORIES

The Model 780 has a wide variety of accessories to assist you with your coating inspection project.



SPRING  
ADAPTER FOR  
ELCOMETER  
SPRINGS  
ITEM #13996



ELECTRODE FLEX  
WAND  
(36" – 72")



SPRING  
ADAPTER FOR  
TINKER & RASOR  
SPRINGS  
ITEM #13995



GROUND CABLE  
(50 FT – 600 FT)



ELECTRODE  
WANDS  
(36" – 72")



SPRING SUPPORT  
PUSHER WAND  
(FOR SPRINGS  
OVER 60")

Please call our office at (713) 681-5837 or email us at [sales@picltd.com](mailto:sales@picltd.com) for more product details or to place an order.

## RELATED EQUIPMENT



SPY® MODEL 785 PORTABLE  
HOLIDAY DETECTOR 1-15 KV



SPY® MODEL 790 PORTABLE  
HOLIDAY DETECTOR 5-35 KV



SPY® MODEL JM JEEPMETER  
(VOLTAGE METER)



SPY® MODEL DCPJM DC POCKET  
JEEPMETER (VOLTAGE METER)



PIPELINE INSPECTION COMPANY

[PICLTD.COM](http://PICLTD.COM)