

# **GENESIS**

**INSTRUCTION MANUAL  
P/N 71-0132  
REV. F**

**THERMO ELECTRON CORPORATION  
ENVIRONMENTAL INSTRUMENTS  
27 FORGE PARKWAY FRANKLIN MASSACHUSETTS 02038**

**(866) 282-0430 Toll Free  
(508) 520-0430 International  
(508) 520-1460 Fax**

**[www.thermo.com/eid](http://www.thermo.com/eid)**

1Dec2003

© 2003 Thermo Electron Corporation. All rights reserved. Thermo Electron Corporation, *question everything*, and *Analyze. Detect. Measure. Control* are trademarks of Thermo Electron Corporation. All other product names and logos are the property of their respective owner.

Specifications, terms and pricing are subject to change. Not all products are available in all countries. Please consult your local sales representative for details.

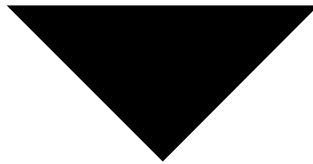

# WARNING



THIS INSTRUMENT IS DESIGNED TO DETECT ONE OR MORE OF THE FOLLOWING:

FLAMMABLE VAPORS, OXYGEN CONTENT, AND/OR TOXIC GAS AND TO GIVE WARNING BEFORE THEY REACH HARMFUL CONDITIONS. IN ORDER TO ENSURE THAT IT WILL WARN OF DANGEROUS CONCENTRATIONS, IT IS ESSENTIAL THAT THE INSTRUCTIONS IN THIS MANUAL, PARTICULARLY THOSE CONCERNING START UP, OPERATION, CALIBRATION, AND MAINTENANCE, BE READ, UNDERSTOOD, AND FOLLOWED.

## NOTATION CONVENTIONS

Notices are used in this operator's manual to alert you to hazardous conditions to person or instrument and to notify you of additional information. This operator's manual uses the following notices.



---

### **WARNING**

Notifies you of potential danger that can result in personal injury or death.

---



---

### **CAUTION**

Notifies you of potential damage to equipment.

---



---

### **NOTE**

Notifies you of additional or critical information.

---

## **SERVICE LOCATIONS**

For additional assistance, Environmental Instruments Division has service available from exclusive distributors worldwide. Contact one of the phone numbers below for product support and technical information.

**866-282-0430 Toll Free**  
**508-520-0430 International**

# WARRANTY

Seller warrants that the Products will operate substantially in conformance with Seller's published specifications, when subjected to normal, proper and intended usage by properly trained personnel, for 13 months from date of installation or 12 months from date of shipment, whichever is less (the "Warranty Period"). Seller agrees during the Warranty Period, provided it is promptly notified in writing upon the discovery of any defect and further provided that all costs of returning the defective Products to Seller are pre-paid by Buyer, to repair or replace, at Seller's option, defective Products so as to cause the same to operate in substantial conformance with said specifications. Replacement parts may be new or refurbished, at the election of Seller. All replaced parts shall become the property of Seller. Shipment to Buyer of repaired or replacement Products shall be made in accordance with the provisions of Section 5 above. Lamps, fuses, bulbs and other expendable items are expressly excluded from the warranty under this Section 8. Seller's sole liability with respect to equipment, materials, parts or software furnished to Seller by third party suppliers shall be limited to the assignment by Seller to Buyer of any such third party supplier's warranty, to the extent the same is assignable. In no event shall Seller have any obligation to make repairs, replacements or corrections required, in whole or in part, as the result of (i) normal wear and tear, (ii) accident, disaster or event of force majeure, (iii) misuse, fault or negligence of or by Buyer, (iv) use of the Products in a manner for which they were not designed, (v) causes external to the Products such as, but not limited to, power failure or electrical power surges, (vi) improper storage of the Products or (vii) use of the Products in combination with equipment or software not supplied by Seller. If Seller determines that Products for which Buyer has requested warranty services are not covered by the warranty hereunder, Buyer shall pay or reimburse Seller for all costs of investigating and responding to such request at Seller's then prevailing time and materials rates. If Seller provides repair services or replacement parts that are not covered by the warranty provided in this Section 8, Buyer shall pay Seller therefore at Seller's then prevailing time and materials rates. ANY INSTALLATION, MAINTENANCE, REPAIR, SERVICE, RELOCATION OR ALTERATION TO OR OF, OR OTHER TAMPERING WITH, THE PRODUCTS PERFORMED BY ANY PERSON OR ENTITY OTHER THAN SELLER WITHOUT SELLER'S PRIOR WRITTEN APPROVAL, OR ANY USE OF REPLACEMENT PARTS NOT SUPPLIED BY SELLER, SHALL IMMEDIATELY VOID AND CANCEL ALL WARRANTIES WITH RESPECT TO THE AFFECTED PRODUCTS.

THE OBLIGATIONS CREATED BY THIS SECTION TO REPAIR OR REPLACE A DEFECTIVE PRODUCT SHALL BE THE SOLE REMEDY OF BUYER IN THE EVENT OF A DEFECTIVE PRODUCT. EXCEPT AS EXPRESSLY PROVIDED IN THIS SECTION 8, SELLER DISCLAIMS ALL WARRANTIES, WHETHER EXPRESS OR IMPLIED, ORAL OR WRITTEN, WITH RESPECT TO THE PRODUCTS, INCLUDING WITHOUT LIMITATION ALL IMPLIED WARRANTIES OF MERCHANTABILITY OR FITNESS FOR ANY PARTICULAR PURPOSE. SELLER DOES NOT WARRANT THAT THE PRODUCTS ARE ERROR-FREE OR WILL ACCOMPLISH ANY PARTICULAR RESULT.





# TABLE OF CONTENTS

## Chapter 1

### Introduction

About the Genesis . . . . .	1
Instrument Specifications . . . . .	2
Sensor Specifications . . . . .	3
Optional Accessories . . . . .	4

## Chapter 2

### Start Up & Operation

Starting Up the Genesis . . . . .	5
Normal Operation . . . . .	6
Interference Factors . . . . .	7
Relative Response . . . . .	8
Using the Pump Adapter . . . . .	9
Using the Extender Cable . . . . .	10
Turning Off the Genesis . . . . .	11
Performing a Bump Test on Power-Up . . . . .	12

## Chapter 3

### Alarms

Gas Alarms . . . . .	15
Battery Alarms . . . . .	16
Sensor Alarms . . . . .	17
Pump Alarm . . . . .	18
Datalog Alarm . . . . .	19
Temperature Alarm . . . . .	19

## Chapter 4

### User Program

About the User Program . . . . .	21
The Display Mode . . . . .	22
Accessing Password-Protected Menus . . . . .	23
Advanced Features Mode . . . . .	24
Edit Alarms . . . . .	25
O <sub>2</sub> Alarm Configuration . . . . .	25
Alarm Latch Option . . . . .	26
Lunch Break Option . . . . .	26
Backlight Delay Selection . . . . .	26
Cal Interval Selection . . . . .	27
Bump Test on Power-Up Option . . . . .	27

---

Advanced Features Mode (cont.)	
Sensor Select . . . . .	28
HC Units Option . . . . .	29
Setting AutoCal Gas Values . . . . .	29
Comfort Alert Options . . . . .	29
Temperature Alarm . . . . .	30
Enter/Edit CalWord/PassWord/LogWord . . . . .	31
Exit . . . . .	31
Datalog Features Menu . . . . .	32
Adjust Date and Time . . . . .	33
Edit Operator, Location, and Instrument ID's . . . . .	33
Log Memory Manager . . . . .	34
Log Averages . . . . .	35
Log Interval . . . . .	35
Log Status . . . . .	36
Clear Log . . . . .	36
Log Began . . . . .	36

## Chapter 5

### Calibration

Assembling the Calibration Kit . . . . .	37
Calibrating the Genesis . . . . .	37
Auto Calibration . . . . .	38
Entering a CalWord . . . . .	39
Toxigen Calibration . . . . .	40
Manual Calibration . . . . .	41
Calibration Alarms . . . . .	43
Sensor Failed Alarm . . . . .	43
Weak Sensor Warning . . . . .	43

## Chapter 6

### Maintenance

Recharging the NiHy Battery Pack . . . . .	45
Replacing Alkaline Batteries . . . . .	46
Replacing Components . . . . .	48
Replacing/Adding a Sensor . . . . .	48
Replacing the Battery Pack . . . . .	49
Replacing the Pump . . . . .	50
Troubleshooting . . . . .	51

## Appendix A

Parts List, Ordering Information, Replaceable Parts . . . . .	55
Parts List, Ordering Information, Accessories . . . . .	56



# INTRODUCTION

## About the Genesis

To get started with the Genesis, go to Chapter 2, Start Up & Operation. To familiarize yourself with the Genesis, continue with this chapter.

The Genesis is a portable gas monitor that simultaneously detects and displays up to 4 gases. It also continuously computes average readings for Short Term Exposure Limit (STEL) and Time Weighted Average (TWA) levels. You can display Peak readings, STEL, and TWA levels on command. The alarm circuit alerts you to dangerous gas conditions, low battery conditions, sensor failure, full datalog, calibration reminder, and sample-draw pump failures. The Genesis is protected by a die cast aluminum housing with rubber end caps and a high-impact polycarbonate display window.

A menu-driven program allows you to update and store many factory set parameters and display various information. With the optional datalogging version and Data Retrieval Package, you can retrieve, display, and save the logged data on a personal computer (PC). Additionally, the Data Retrieval Package gives you full instrument setup and programming capability.

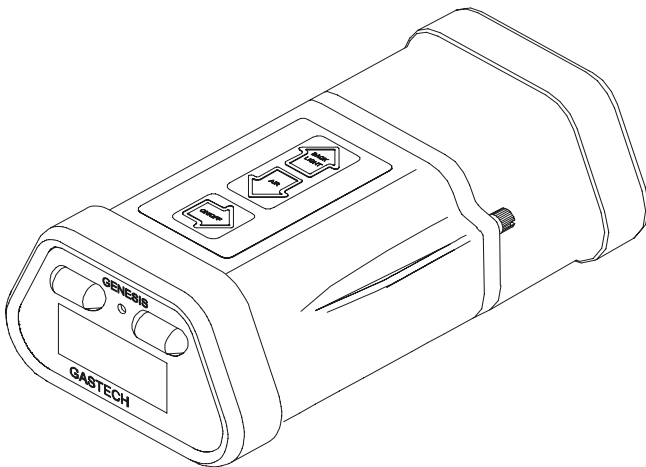

**Figure 1-1 The Genesis Gas Monitor**

## Instrument Specifications

Table 1-1 lists instrument specifications for the Genesis.

**Table 1-1 Genesis Instrument Specifications**

---

Housing Material	Aluminum casting with molded end caps
Regulatory Listings	UL Classified CSA and LCIE certified for intrinsic safety
Area Classification	Class I, Division 1; Groups A, B, C and D (UL/CSA) EEx ia D IIC T4 (LCIE)
Power Source	Battery Pack (3 AA-size Alkaline cells or NiHy)
Battery Life, without sample-draw pump 68°F (20°C)	22 hours, alkaline 16 hours, NiHy
Battery Life, with sample-draw pump 68°F (20°C)	11 hours, alkaline 8 hours, NiHy
Operating Temperature	-4°F to 113°F (-20°C to 45°C)
Storage Temperature	-22°F to 149°F (-30°C to 65°C)
Humidity Range	0 to 95% RH (non-condensing)
Dimensions	2.25 in. H X 3.7 in. W X 6.0 in. D (5.62 cm X 9.25 cm X 15.0 cm)
Weight	16 ounces (454 grams)
Sampling Method	Diffusion (standard) Sample-draw (optional internal pump) Extender Cable (optional)
Standard Accessories	Operator's manual, quick reference card, shoulder strap

---

**Sensor Specifications****Table 1-2 Genesis Sensor Specifications and Factory Default Settings**

Target Gas	Display Increments	Range	Low Alarm	High Alarm	TWA Alarm	STEL Alarm
HC	1% LEL	0 to 100 %LEL	10	50	N/A	N/A
HC	0.1% VOL	0 to 5.0% VOL	0.5% VOL	2.5% VOL	N/A	N/A
O <sub>2</sub>	0.1% VOL	0 to 30.0 % VOL	19.5	23.5	N/A	N/A
H <sub>2</sub> S	1 PPM	0 to 200 PPM	10	15	10	15
CO	1 PPM	0 to 250 PPM	25	200	25	200
Cl <sub>2</sub>	0.1 PPM	0 to 9.9 PPM	0.5	1.0	0.5	1.0
HCN	1 PPM	0 to 30 PPM	5	10	5	10
NH <sub>3</sub>	1 PPM	0 to 100 PPM	25	35	25	35
NO	1 PPM	0 to 100 PPM	25	75	25	75
NO <sub>2</sub>	0.1 PPM	0 to 9.9 PPM	3.0	5.0	3.0	5.0
PH <sub>3</sub>	0.01 PPM	0 to 3.00 PPM	0.3	1.0	0.3	1.0
SO <sub>2</sub>	0.1 PPM	0 to 9.9 PPM	2.0	5.0	2.0	5.0

## Optional Accessories

Table 1-3 lists optional accessories for the Genesis. See Appendix A, for ordering information on parts and accessories...

**Table 1-3 Genesis Optional Accessories**

Battery pack (NiHy or Alkaline)	Alternate battery packs are available to power the Genesis. The NiHy battery pack is rechargeable; the alkaline battery pack has 3 "AA" replaceable alkaline cells.
Battery charger (NiHy)	Allows you to recharge the NiHy battery pack. Available for 115 and 230 VAC, and 12 VDC.
Sample-draw pump Assembly*	Used with the internal pump version of the Genesis. Allows you to sample a remote environment. Includes adapter cup, hose and probe with hydrophobic filter.  * Several optional hose lengths available.
Sample-draw aspirator Assembly**	Allows you to sample a remote environment. Uses manually-operated aspirator bulb to draw sample past sensors for non-internal pump versions.
Extender Cable	Extender cable allows for remote sensor detection. 20' and 50' extender cables available.
Calibration kit	Contains all equipment necessary to calibrate the Genesis.
Carrying case	Allows you to carry the Genesis and keep your hands free. The display screen is visible through the carrying case, and the sensors are uncovered. You can use with or without the sample-draw accessories and extender cable.
Storage cases	Small case allows you to safely store the Genesis, battery charger, extra battery pack, shoulder strap, and operator's manual. Large case stores the same as the small plus an extender cable or sample-draw pump assembly.
Data retrieval kit	Contains program disks and appropriate cables to connect the Genesis to a PC and retrieve the data stored in the datalog memory. You can also edit or update all factory default settings.
Battery Conditioning Station	Conditions and charges up to six NiHy battery packs. Includes power cord, specify 115 or 240 VAC operation.



### NOTE

\* Maximum hose length of 5' for Genesis units with Toxigen sensors.

\*\* Not recommended for use with Toxigen sensors.

---

## START UP & OPERATION

### Starting Up the Genesis

Perform the following procedure to start up the Genesis.



---

#### NOTE

For NiHy versions, recharge the battery pack before you start up the Genesis for the first time. For alkaline versions, use fresh alkaline batteries. Wait 15 minutes for the toxic sensors to stabilize before turning the instrument on. If the unit is started up immediately after installing batteries, the “BIAS” message (See Note below) may appear. See Chapter 6, Maintenance, for instructions on installing or recharging batteries.

---

1. Press and hold the ON/OFF button for one second. The Genesis begins the warm-up period. Several messages appear during the warm-up period, starting with the model and software version. Other screens displayed are:
  - Battery capacity on a scale from E (empty) to F (full capacity) for new alkaline or a fully charged battery pack.
  - Datalogging days left for datalogging versions.
  - Settings for High, Warning, STEL, and TWA alarms.
  - The CAL DUE # DAYS indicates when the Genesis is due for calibration according to the schedule you accepted in the user program, provided the calibration interval is not set to “No CAL Reminder”.



---

#### NOTE

During the warm-up period the Genesis determines if the toxic sensors are properly biased. If the sensors require additional biasing, the screen continuously displays “BIAS” with alarms instead of the gas reading. Once the readings fall within acceptable limits, a fixed time-out is initiated. During this time-out, the display will alternate between “BIAS” and the sensor(s) reading. If an air adjust is performed during this time-out period, it will not adjust the sensor(s) that are experiencing the ‘bias time-out’ but will adjust the other sensors.

---

2. When the warm-up is complete, the buzzer will beep, lights will flash several times, and display will read “WARM UP COMPLETE”.



---

**NOTE**

If the Bump Test is set to “BUMP TEST ENABLED” the display will cue the operator to perform an “Air Adjust” and then apply test gas. See Bump Test at the end of this chapter for instructions.

---



---

**WARNING**

**Complete the air-adjust procedure in a “fresh air” environment (air free of all target gases and of normal oxygen content).**

---

3. Hold down the AIR button for 3 seconds until the display counts down and then reads “DONE” to set the fresh air reading for all active sensors.



---

**NOTE**

After you “Air Adjust”, a “XXX” sensor failure may appear on the display screen. See Chapter 3, Sensor Failure, to respond to these messages.

---

## Normal Operation

Normal operation is defined as any time after the warm-up period is complete and the Genesis is not alerting you to an alarm or failure.

After warm up is complete, the Genesis simultaneously displays the current gas concentration for all active sensors and the NORM icon. This display screen is defined as the normal screen. The sensor labels will alternate between the gas type and unit of measure.

While in normal operation, press the BACKLIGHT button to illuminate the display screen.



---

**NOTE**

If the Comfort Alert is enabled, the Genesis will send 2 beeps every 3 minutes to remind the operator that the unit is turned on and functioning. This feature can be disabled or enabled by the operator, see Chapter 4, Comfort Alert, for activating/deactivating this feature.

---

## Interference Factors

The following factors may interfere with the sensors and produce inaccurate readings or cause the sensor to fail.



---

### **WARNING**

**The flame arrestor for the hydrocarbon (HC) sensor may not be sufficient for oxygen-rich samples.**

---

- Oxygen-deficient samples (10% O<sub>2</sub> or less) may cause an inaccurate (lower) combustible gas reading.
- Very rich HC samples (above the Upper Explosive Limit) may read close to zero. The HC reading increases to 100% LEL, then decreases as the HC sensor is exposed to the rich sample.
- Silicone, chlorine, and fluorine compounds can “poison” the HC sensor and cause inaccurate combustible gas readings.

Avoid exposing the HC sensor to poisonous compounds. Bump test or calibrate the HC sensor frequently if the possibility of exposure to poisonous compounds exists.

- The carbon monoxide (CO) sensor is sensitive to several interfering gases (for example, hydrogen sulfide ). The sensor contains a filter to prevent interference of some gases; however, prolonged exposure to these gases will saturate the filter and eventually appear on the display screen as a CO reading.
- Hydrogen, ethylene, and acetylene are strong interfering gases for the CO sensor, and are not removed by the interference filter. Heavier olefins and aromatic hydrocarbons are weaker interfering gases; however, these gases may give a CO indication over time.



---

### **WARNING**

**LEL response will vary for different gases. For best accuracy, LEL calibration should use the gas intended to be detected. Expected relative combustible responses, listed in Table 2-1 are not verified by UL.**

---

## Relative Response

The HC sensor is factory-calibrated on the gas that is listed on the packing slip. However, the sensor responds to various hydrocarbons as shown in the table below.

**Table 2-1 Relative Response Chart for the HC Sensor**

Combustible Gas	Methane Factor	Hexane Factor
Acetone	1.43	0.67
Butadiene	1.05	0.49
Carbon monoxide	0.84	0.39
Ethanol	1.27	0.59
Ethylene Oxide	1.68	0.78
Hexane/Gasoline	2.13	1.00
Hydrogen	0.90	0.42
Kerosene/Heptane	2.21	1.03
Methane	1.00	0.47
Methyl Ethyl Ketone	2.47	1.15
Pentane	2.39	1.12
Propane	1.32	0.62
2-Propanol	1.69	0.79
Propylene	1.18	0.55
Toluene	1.82	0.85
Trichloroethylene	19.20	9.00
Xylene	2.02	0.95

Please note that response varies from one sensor to another and the relative response of a sensor can change with the age of the sensor. This data should be used for estimation purposes only.

Assuming an instrument calibrated directly for hexane or methane but used to observe a different gas, the equivalent response in %LEL for that gas is secured by multiplying the observed reading by the scale conversion factor.



## Using the Pump Adapter

The pump adapter attaches to the sensor end of the internal pump versions of the Genesis. To attach the pump adapter:

1. Remove rubber end cap from sensor end.
2. Attach the cup of the pump adapter to the sensor end of the Genesis and firmly tighten the screw, using a screwdriver if necessary.
3. Turn on the Genesis, then place the probe in the monitoring area.



### NOTE

The pump indicator icon is in motion when the pump is working. If the flow rate of the pump is insufficient, the pump indicator icon stops revolving, an “X” appears in the center of the display, and the Genesis alerts you with a pump alarm see Chapter 3, Pump Alarm.



### NOTE

The “X” will also appear when the battery voltage drops below a pump threshold voltage. If the pump is on when the battery falls below the threshold the pump will remain on with the pump icon spinning. If the pump is turned off by removing the pump adapter, the “X” will appear and the pump will not turn back on unless batteries are replaced or recharged. If the instrument is shut off and then turned on again the “X” may appear after the warm-up period and the pump will not turn back on unless the batteries are replaced or recharged.

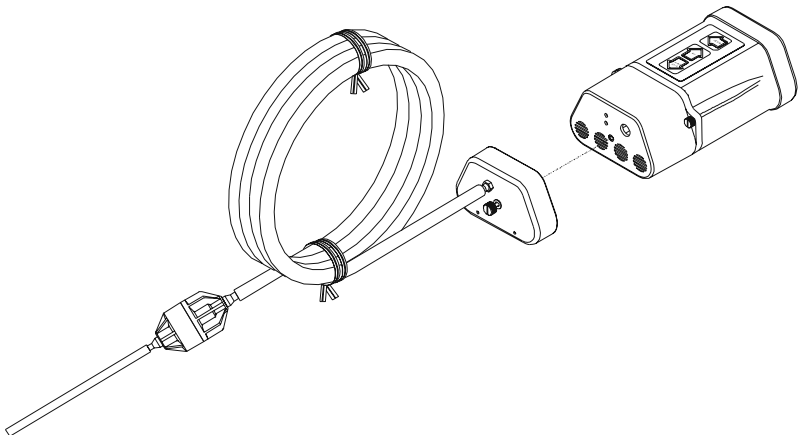

Figure 2-1 Attaching Pump Adapter

## Using the Extender Cable

The optional 20' or 50' extender cable attaches to any version of the Genesis. To attach the extender cable:

1. Turn off the Genesis.
2. Loosen the two captive screws that secure the sensor housing to the main housing.
3. Gently pull the sensor housing away from the main housing. Pull straight back, do not rock the two housings.
4. Attach the extender cable housing marked "MAIN" to the main housing of the Genesis. Secure by tightening the two captive screws on each side.
5. Attach the extender cable housing marked "SENSOR" to the sensor housing of the Genesis. Secure by tightening the two captive screws on each side.
6. Turn on the Genesis.
7. After the warm-up cycle, perform a fresh Air Adjust.



### NOTE

After you "Air Adjust", a "XXX" sensor failure may appear on the display screen. See Chapter 3, Sensor Failure, to respond to these messages.

8. Place the sensor housing in monitoring area.

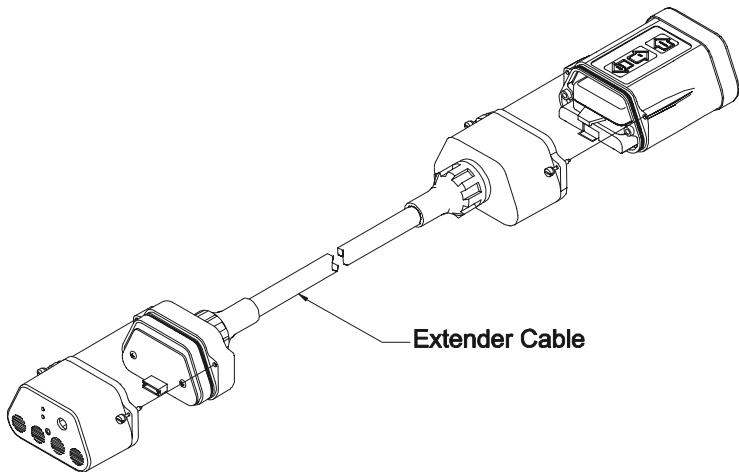

Figure 2-2 Attaching the Extender Cable

## Turning Off the Genesis

To turn off the Genesis, hold down the ON/OFF button for 3 seconds. A power off message on the display screen counts down from 3. The Genesis sounds a pulsing tone, and the backlight automatically turns on during the power off sequence.

To cancel the power off command, release the ON/OFF button before the display screen goes blank.



### NOTE

The STEL, TWA, maximum, and minimum (for O<sub>2</sub>) readings are automatically reset unless the Lunch Break mode is enabled. See Chapter 4, Lunch Break Option for more detail.

---



### CAUTION

**If the Genesis will not be turned on for more than 2 weeks, remove the battery pack from the instrument and the alkaline batteries from the pack. Failure to remove the alkaline batteries prior to storage could result in damage to the pack and/or instrument.**

**If rechargeable, charge the battery pack before you turn the Genesis on.**

**After installing the batteries into the Genesis allow the toxic gas sensors (if applicable) to stabilize for 15 minutes before turning the Genesis on.**

---

## Performing a Bump Test on Power-Up

When the Bump Test option is set to “BUMP TEST ENABLED” the display alerts the operator to perform a Bump Test after the warm-up cycle is complete. See Chapter 4, Bump Test Option.

To perform the bump test:

1. Assemble the calibration kit. See Chapter 5, Calibration.
2. Remove the rubber end cap from the sensor end of the Genesis by loosening the captive screw.
3. Turn on the Genesis and wait for it to complete the warm-up cycle. The display will read “AIR ADJUST NOW”. The screen will blink on and off with alternating lights, prompting the operator to perform a fresh Air Adjust.
4. Press and hold the “AIR” button for three seconds until “DONE” appears. Once the Genesis has been Air Adjusted, the display will begin counting down, and prompt the operator to “APPLY GAS”, alternating with “BUMP TEST”. An audible beep will sound.



### NOTE

If an Air Adjust is not performed within 30 seconds, a “BUMP TEST INCOMPLETE” message appears and the buzzer beeps on and off for three seconds. The Genesis will return to the Normal Operating Mode.

---

5. Attach the calibration cup to the sensor end of the Genesis and tighten the captive screw.
6. Turn the regulator on.
7. The Genesis should respond to the detected gas and single beep to indicate that a Bump Test is being performed. All gas levels for standard gases are displayed as in the Normal Operating Mode.



### NOTE

If no gas is detected during the “Apply Gas” countdown, a “BUMP TEST INCOMPLETE” message appears and the buzzer beeps on and off for 3 seconds. The Genesis will return to Normal Operating Mode.

---

Once gas is detected a countdown is initiated. During this single beep countdown the user should visually verify the sensors are responding correctly.



**NOTE**

On datalogging versions, the Bump Test peak readings are recorded. Events are recorded as “Bump Test Complete” if the Genesis detected gas, and “Bump Test Aborted” if the Genesis did not detect gas.

---

A “BUMP TEST COMPLETE” message will be displayed. Then the screen will alternate between “REMOVE GAS” and the gas readings. Once the instrument detects the gas has been removed the screen display an “ALARMS SILENCED” message. The alarms will be silenced for a blind 30 second count.

After the 30 second count has elapsed an “ALARMS ACTIVE” message will display briefly, audible alarms will be enabled and the Genesis will return to the Normal Operating Mode.



**NOTE**

If the Genesis does not respond properly during the Bump Test, follow the instructions in Chapter 5, Calibration, or Chapter 6, Troubleshooting sections of this manual.

---

8. Remove the Calibration Cup and install the protective rubber endcap.



**NOTE**

For Toxigen instruments calibration gases are only available in single-gas cylinders. Therefore a multi-step bump process has been programmed into the bump test routine. First, the standard sensors are bumped using a multi-gas mixture. Then the first Toxigen sensor is bumped using a single-gas cylinder and repeated if your unit has a second Toxigen sensor.

For pump adapter units, (due to the sensitivity of the sensors), it is required to perform the bump test with the pump adapter attached.

A special demand flow regulator (see parts list, Appendix A) is required for the pump to draw the gas from the pressurized cylinder.

---



**WARNING**

**Avoid using a gas mixture containing H<sub>2</sub>S for bump testing an instrument with Cl<sub>2</sub>, NH<sub>3</sub> or NO<sub>2</sub> sensors.**

---



# ALARMS

This chapter describes Genesis alarm indications, display messages, and response for the following types of alarms:

- Gas Alarms
- Battery Alarms
- Failure Alarms
- Datalog Alarm
- Temperature Alarm

## Gas Alarms

This section describes alarm indications, display messages, and response to Low, High, STEL, and TWA gas alarms. The backlight automatically turns during all gas alarms.

### Gas Alarm Indications

Table 3-1 lists the indications for each type of gas alarm.

**Table 3-1 Alarm Indications (Gas Alarms)**

Alarm	Display	Light/Buzzer
Low Gas Alarm	Reading flashes	slow flashing/pulsing
High Gas Alarm	Reading flashes	fast flashing/pulsing
Decreasing O <sub>2</sub> Alarm	Reading flashes	fast flashing/pulsing
Increasing O <sub>2</sub> Alarm	Reading flashes	fast flashing/pulsing
STEL Gas Alarm	STEL icon	flashing/pulsing
TWA Gas Alarm	TWA icon	flashing/pulsing

## Responding to Gas Alarms

1. Follow the established procedure for the type of gas alarm (Low, High, STEL, or TWA). If a procedure is not in place, establish one that is appropriate for your application.
2. Reset the alarm circuit. The Genesis resets the circuit according to the alarm reset setting “LATCH AUTO” or “LATCH MANUAL”. See Chapter 4, Alarm Latch option to enter the program and display and/or update the setting.
  - If the alarm reset setting is **latch auto reset**, the Genesis resets the applicable alarm circuit after the gas reading falls below the alarm setting (or rises above for decreasing O<sub>2</sub>).
  - If the alarm reset setting is **latch manual reset**, press the ON/OFF button to reset the alarm circuits after the gas reading falls below the alarm setting (or rises above for decreasing O<sub>2</sub>).

## Battery Alarms

This section describes alarm indications, display messages, and response for the following battery alarms: Low Battery and Replace Battery. The backlight automatically turns on during all battery alarms

### Battery Alarm Indications.

**Table 3-2 Alarm Indications (Battery Alarms)**

Alarm	Display	Light/Buzzer
Low Battery	LOW BATTERY	double flash/beep (every two minutes) battery icon flashes
Battery Failure	REPLACE BATTERY	constant flash/beep battery icon steady

## Responding to Battery Alarms

This section describes response to Low Battery and Replace Battery alarms.

1. For Low Battery alarm, proceed to step 2 as soon as possible. The Genesis will continue to function properly for approximately 1/2 hour until the Replace Battery screen and alarm sounds. For battery failure alarm, turn off the Genesis immediately. It is not functioning as a gas detection device.
2. Recharge the NiHy battery pack or replace all 3 “AA” cells in the alkaline battery pack. See Chapter 6, Replacing NiHy or Alkaline Batteries.



## Sensor Alarms

This section describes alarm indications, display messages, and response to sensor failure alarms. The backlight automatically turns on during all failure alarms.

### Sensor Alarm Indications

Table 3-3 lists the indications for each type of failure alarm.

**Table 3-3 Alarm Indications (Failure Alarms)**

Alarm	Display	Light/Buzzer
Sensor Failure	XXX	Continuous

### Responding to Sensor Alarms

A sensor failure alarm can occur during normal operation or calibration. Alarms that occur during calibration are described in Chapter 5, Calibration.

1. Examine the display screen to determine which sensor is failing. The failing sensor displays “XXX” instead of the gas reading for a sensor that has failed Air Adjust or Calibration, or “XXX” in place of the gas type for a missing sensor.
2. Turn off the Genesis.
3. Remove the two captive screws on the sides of the Genesis to access the interior.
4. Remove the two screws from the sensor board and pull out the sensor board. Verify that the “failing” sensor is installed properly.
5. If necessary, replace the sensor. See Chapter 6, Replacing/Adding a Sensor.
6. You can enter the Genesis User Program and change the sensor status setting to “OFF”. All information for an absent sensor is removed from the normal screen and recorded as a blank in the datalog.

## Pump Alarm

This section describes alarm indications, display messages, and response to sensor, memory, and pump failure alarms. The backlight automatically turns on during all failure alarms.

### Pump Alarm Indications

Table 3-4 lists the indications for each type of failure alarm.

**Table 3-4 Alarm Indications (Failure Alarms)**

Alarm	Display	Light/Buzzer
Pump Failure	PUMP FAILED → TO RESET	pulsing/beeping (every 5 seconds)

### Responding to a Pump Alarm

1. Verify that the pump adapter is properly connected to the pump fitting.
2. Check the hose, probe, and filter for flow restrictions or leaks.
3. Press the ON/OFF button to reset the alarm circuit and return to the normal screen.
4. If the pump failure alarm continues, see Chapter 6, Replacing the Pump, or contact **Thermo** GasTech for further instruction.

## Datalog Alarm

This section describes the alarm indication, display message, and response for the datalog full alarm. A datalog full alarm occurs when the datalog becomes full and the datalog full command was accepted as STOP ON FULL.

### Datalog Alarm Indications

Table 3-5 lists the indications for the datalog full alarm.

**Table 3-5 Alarm Indications (Datalog Full Alarm)**

Alarm	Display	Light/Buzzer
Datalog Full	LOGGING STOPPED	flashing/pulsing (every 30 seconds)

### Responding to the Datalog Alarm

Perform one of the following procedures to reset the datalog alarm.

- Download the data.
- Enter the datalog features menu, and update the datalog full command to OVRWRITE ON FULL. See Chapter 4, Log Memory Manager option.
- Enter the Datalog Features Menu and clear the datalog. See Chapter 4, Clear Log Memory.

## Temperature Alarm

The Genesis has an alarm to alert the user that the unit is being operated at a temperature that exceeds its operating specification of  $-20^{\circ}\text{C}$  to  $+45^{\circ}\text{C}$  ( $-4^{\circ}\text{F}$  to  $+113^{\circ}\text{F}$ ). If the temperature is outside this range, the following message appears every 30 seconds:

The buzzer beeps and lights flash twice every 30 seconds, and the condition will clear automatically when the temperature returns to within the operating limits.



### NOTE

The temperature alarm is user enabled or disabled, with the default setting “disabled”. See Chapter 4, Temperature Alarm.



# USER PROGRAM

This chapter includes an introduction to the Genesis User Program and step-by-step procedures to run the program.

## About the User Program

The Genesis User Program allows you to view and update factory-set parameters and display several items, such as the battery voltage, datalog status (capacity), current temperature, time, and date.

The menu-driven program has three main menus:

- The Display Mode
- The Advanced Features Menu
- Datalog Features Menu (for versions with optional datalogging)

The user navigates through the user program by using the three buttons: → or ON/OFF, ↑ or AIR, and ↓ or BACKLIGHT.

- The right arrow (→) is used to **accept** within the menu.
- The up arrow (↑) and down arrow (↓) are used to **scroll** either forward or backwards through the menu.



---

### NOTE

The Genesis has a time-out feature. If no buttons are pressed for 10 seconds while in the Display, Advanced Features or Datalog Features Menu the display will flash and buzzer will beep for 10 seconds. If no buttons are pressed during this time, the Genesis will return to the Normal Operating Mode.

---

## The Display Mode

In the Display Mode the following may be viewed:

- Battery Capacity
- Peak Readings (Option to Clear)
- STEL Levels (Toxic Sensors Only)
- TWA Levels (Toxic Sensors Only)
- Temperature
- Date and Time
- Operator ID (Option to Change)
- Location ID (Option to Change)
- Exit



### NOTE

Non-datalogging versions do not display Date and Time, Operator ID, or Location ID screens.

---

To enter The Display Mode:

1. Press and hold the BACKLIGHT button for three seconds. The display will show "DISPLAY MODE" and count down from 3 seconds. Your first screen will display the Battery Capacity.
2. To scroll to the next screen, use the ↑ button. To scroll backwards through the menu, press the ↓ button. Continue to scroll through the screens to display the desired information, clear Peak Readings, or change an Operator or User ID.
3. To exit the program, press either ↑ or ↓ until you get to the 'EXIT' display, then press → to exit to the Normal Operating Mode.

To change a User or Operator ID:



### NOTE

Operator and Location must first be entered before a selection can be made. See Edit Operator, Location, and Instrument ID's.

---

1. For the Operator ID and Location ID screens, to change the selection press the → button, and then use ↑ or ↓ to designate a new selection.
2. Press the → button to accept the selected ID.



### NOTE

When Peak values are displayed, after three seconds the display reads "PRESS → TO CLEAR", so the user can clear peak values if needed.

---

---

## Accessing Password-Protected Menus

A password may be used to add extra security to the following menus:

- Advanced Features protected by “PASSWORD”
- Datalogging Menu protected by “LOGWORD”
- Calibration Menu protected by “CALWORD”

See Create/Edit CalWord/PassWord/LogWord for details on creating a password. If enabled, a code must be entered before the user may enter these menus.

To enter a PassWord, LogWord, or CalWord:

1. Press and hold  $\uparrow$  and  $\downarrow$  for three seconds. The message “FEATURES MODE” appears on the display and counts down from 3 seconds, and then displays “BEGIN CAL”. Continue and press  $\downarrow$  to scroll to “ADVANCED FEATURES” or “DATALOG MENUS”.
2. Stop scrolling at the desired screen and press  $\rightarrow$  to accept. The display now reads “PASSWORD”, “LOGWORD”, or “CALWORD” and “\* \* \*” (if protection has been enabled). The cursor is on the first asterisk.



### NOTE

If the “\*\*\*” does not appear when entering any of the three modes, security protection is not enabled.

---

3. Press  $\uparrow$  or  $\downarrow$  to scroll to the correct character.
4. Press  $\rightarrow$  to accept. The cursor moves to the next character.
5. Repeat steps 4 and 5 until all three characters are accepted. If your entry is correct, you will advance to the next screen. If your entry is incorrect, you will return to the original screen. Begin at step 2 to retry your password.

## **Advanced Features Mode**

The Advanced Features Mode allows you to change the parameters of the instrument. The factory default value is indicated after the menu title in parenthesis.

The menu is as follows:

- Edit Alarms
- O2 Alarm Configuration
- Alarm Latch Option
- Lunch Break Option
- Backlight Delay Selection
- Calibration Interval Selection
- Bump Test Option
- Sensor Select
- HC Units Option
- Setting Auto Cal Gas Values
- Comfort Alert Options
- Temperature Alarm
- Pump Threshold
- Change Cal Word
- Change Password
- Change Logword
- Exit

To enter the Advanced Features Mode:

1. Press and hold both the AIR and BACKLIGHT buttons for three seconds. The screen displays “FEATURES MODE” and counts down from 3.
2. The first screen displayed after the countdown is “BEGIN CAL”. Press the ↓ button, then press the → button. If prompted by “PASSWORD” and “\*\*\*”, enter a password as described in the previous section, Accessing Password-Protected menus. When entered correctly, or if PassWord is not enabled, you are now at the first option “EDIT ALARMS” in the Advanced Features Menu.





**NOTE**

The Genesis has a time-out feature. While in the Advanced Features Mode, if a button is not pressed within 10 seconds the display will flash and the buzzer will beep for 10 seconds. If no button is pressed during the 10 seconds, the Genesis will return to normal mode.

---

**EDIT ALARMS**

This allows the user to increase or decrease the High and Low Alarms for each gas. See Chapter 1, Sensor Specifications for factory default settings.

1. Press → to enter the HC screen. The high alarm reading will flash.
2. Press ↑ or ↓ to increase or decrease the alarm setting. If you choose to keep the alarm as is, press → to move to the next alarm setting.
3. Continue step 2 until you have set all gas alarms. After the last gas alarm is set, the display automatically returns to the “EDIT ALARMS” screen.



**NOTE**

You will scroll through the following gas alarms, appropriate to your version of Genesis: HC, O2, TOXIC1, TOXIC2.

---

4. Press ↑ or ↓ to continue scrolling through the Advanced Features Menu.

**O2 ALARM CONFIGURATION**

This option allows you to set the oxygen alarms (High and Low) to either increasing or decreasing.

Options you can choose are:

- ONE INC/ONE DEC - The warning alarm is set to decreasing at 19.5% VOL and high alarm increasing at 23.5% VOL.
- TWO ALRM/DECREASE - Both alarms are set to decrease. Warn at 19.5% VOL and High at 18.0% VOL.
- TWO ALRM/INCREASE - Both alarms are set to increase. Warn at 22.5% VOL and high at 23.5% VOL.

The factory default setting is “ONE INC/ONE DEC”.

To enter this mode from the Advanced Features Mode:

1. Press → to accept “O2 ALARM CONFIG”.
2. Press ↓ or ↑ to scroll through the settings. Press the → to accept the setting.
3. Press ↓ to continue scrolling through the Advanced Features Menu.

### **ALARM LATCH OPTION**

This option changes the alarm setting to either automatic reset (LATCH AUTO) or latching (LATCH MANUAL). The factory default setting is "AUTO RESET".

1. Press → to accept "ALARM LATCH".
2. Press ↓ or ↑ to scroll between settings. Press → to accept the setting.
3. Press ↓ to continue scrolling through the Advanced Features Menu.

### **LUNCH BREAK OPTION**

The lunch break option allows the user to either reset averages (STEL and TWA) or retain averages when the Genesis is turned off. The factory default setting is "RESET AVERAGES".



#### **NOTE**

If the lunchbreak mode is set to "RETAIN AVERAGES", the Genesis will retain the STEL and TWA averages when turned off. If the lunchbreak mode is set to "RESET AVERAGES", the Genesis will reset the averages when turned off.

---

To change the lunch break mode from the Advanced Features Menu:

1. Press → at the screen "LUNCH BREAK".
2. Press ↓ or ↑ to scroll through the settings. Press → to accept the setting.
3. Then press ↓ to continue scrolling through the Advanced Features Menu.

### **BACKLIGHT DELAY SELECTION**

The backlight delay feature sets the number of seconds the backlight is illuminated after the "BACKLIGHT" button is pressed. The factory default is setting is 5 seconds. Your options are in 5 second increments up to 60 seconds, and 2, 3, 5, or 10 minutes.

To change the backlight delay setting from the Advanced Features Menu:

1. Press → at the screen "BKLIGHT DELAY".
2. Press ↓ or ↑ to scroll through the settings. Press → to accept the setting.
3. Then press ↓ to continue scrolling through the Advanced Features Menu.

---

## CAL INTERVAL SELECTION

This sets the number of days between calibrations.



### NOTE

The number of days left until calibration is displayed during the warm-up cycle. When the Genesis is due for calibration, display reads “CAL OVERDUE” and buzzer and lights, pulse and flash after the warm-up cycle is complete.

---

Your options are No CAL Reminder, 1 to 6 one-day increments and 1 to 26 one-week increments. The factory default setting is “NO CAL REMINDER”, which means the calibration reminder function is turned off.



### NOTE

For **optimum** performance, calibrate the Genesis before every use.

---

To change the calibration reminder setting from the Advanced Features Menu:

1. Press → at the screen “CAL INTERVAL”.
2. Press ↓ or ↑ to scroll through the settings.
3. Press → to accept the setting.
4. Then press ↓ to continue scrolling through the Advanced Features Menu.

## BUMP TEST ON POWER-UP OPTION

The Bump Test Option enables or disables the Genesis to cue the user to apply gas for a Bump Test immediately after the Genesis warm-up cycle is complete. The factory default setting is “BUMP TEST DISABLED”.

To change the bump test setting from the Advanced Features Menu:

1. Press → at the screen “BUMP TEST”.
2. Press ↓ or ↑ to scroll between “BUMP TST DISABLED” to “BUMP TST ENABLED”.
3. Press → to accept the setting.
4. Then press ↓ to continue scrolling through the Advanced Features Menu.

## SENSOR SELECT

The sensor select function turns the sensor(s) on or off for HC and O<sub>2</sub>, and for toxic sensors, also allows you to select the sensor type installed for the remaining sensor(s). When any gas other than “OFF” is selected the sensor readings and averages are shown during Normal Operation and in the Display Mode.



### WARNING

**The Genesis does not display gas readings, initiate alarms, compute averages, or store data for “OFF” sensor(s).**

---

To change the sensor select setting from the Advanced Features Menu:

1. Press → at the screen “SENSOR SELECT”. All four gases and their settings will display. The cursor and reading will flash for HC.
2. Press ↑ or ↓ to change the setting to “ON” or “OFF”. If you choose to keep the setting, as is, press → to move on to the O<sub>2</sub>.
3. Repeat step 2 for O<sub>2</sub>, press → to move on to the H<sub>2</sub>S (Toxic 1) sensor.



### CAUTION

**The selected gas type(s) in the Sensor Select screen must match the sensor type installed in the H<sub>2</sub>S (Toxic 1) and CO (Toxic 2) locations or improper calibration and false readings are likely to occur.**

---

4. Press ↑ or ↓ to select/change the gas type or to turn the sensor “OFF”. If you choose to keep the setting, as is press → to move on to the CO (Toxic 2) sensor.
5. Repeat step 4 for CO (Toxic2), press → to accept the setting and exit back to the Advanced Features menu.



### NOTE

You will scroll through the following sensor selections, appropriate to your version of Genesis: HC, O<sub>2</sub>, H<sub>2</sub>S (Toxic 1), CO (Toxic 2).

---

## HC UNITS OPTION

This function changes the hydrocarbon units to be displayed in either %LEL or %VOL. The factory default setting is “%LEL”.

To change the hydrocarbon units setting from the Advanced Features Menu:

1. Press → at the screen “HC UNITS”.
2. Press ↓ or ↑ to scroll between “%LEL” to “%VOL”.
3. Press → to accept the setting.
4. Press ↓ to continue scrolling through the Advanced Features Mode.

## SETTING AUTOCAL GAS VALUES

This function allows you to set the auto calibration values to the concentration of the cylinders you are using.



### NOTE

The factory default settings for a standard four gas instrument are HC 50%LEL, O<sub>2</sub> 12.0%VOL, H<sub>2</sub>S 25 PPM, and CO 50 PPM. These are the values that match **Thermo** GasTech’s multi-gas cylinders.

---

To change the value(s) from the Advanced Features Menu:

1. Press → at the screen “AUTOCAL GAS VAL”. All four gases and their values will display. The cursor and reading will flash for HC.
2. Press ↑ or ↓ to change value up or down.
3. Once you’ve reached the desired value, press → to move on to the O<sub>2</sub>. If you choose to keep the setting, as is, press → to move on to the next sensor.
4. Continue this process through all gases.



### NOTE

You will scroll through the following autocal gas values, appropriate to your version of Genesis: HC, O<sub>2</sub>, TOXIC1, TOXIC2.

---

## COMFORT ALERT OPTIONS

The comfort alert is a friendly reminder that the instrument is on and working. The reminder begins 3 minutes after the last button press and will sound every 3 minutes while in the Normal Operating Mode. The alert has four options:

- Beep Only - Every three minutes the buzzer sounds.
- Blink Only - Every three minutes the lights flash.
- Blink and Beep- Both buzzer beeps and lights flash every three minutes.
- Both Off - Option disabled.

The factory default setting is “BLINK AND BEEP”.



---

**NOTE**

The 3 minute comfort alert timer is reset after any button is pressed by the user.

---

To change the setting from the Advanced Features Menu:

1. Press → at the screen “COMFORT ALERT”.
2. Press ↓ or ↑ to scroll through the options.
3. Press → to accept the setting. Press ↓ to continue scrolling through the Advanced Features Menu.

**TEMPERATURE ALARM**

The Genesis has an alarm to alert the user that the Genesis is being operated at a temperature that exceeds its operation specification of -4°F to 113°F (-20°C to 45°C). When the temperature alarm is activated, the buzzer and lights are on continuously. The factory default setting is “TEMP ALARM DISABLED”.

To change the setting from the Advanced Features Menu:

1. Press → at the screen “TEMP ALARM”.
2. Press ↓ or ↑ to change to either “TEMP ALR DISABLED” or “TEMP ALR ENABLED”.
3. Press → to accept the setting.
4. Press ↓ to continue scrolling through the Advanced Features Menu.

**SELECTING PUMP THRESHOLD**

This setting allows the operator to adjust the low flow threshold for different pump current. The default setting is “LOW”, and the setting normally is only changed when the pump is replaced.

1. Press → at the screen “PUMP THRESHOLD”.
2. Press ↑ or ↓ to change the setting to either “PUMP LOW THRESHOLD” or “PUMP HI THRESHOLD”.
3. Press → to accept the setting.
4. Press ↑ to continue scrolling through the Advanced Features Menu.

## **ENTER/EDIT CALWORD, PASSWORD, OR LOGWORD**

These options add extra security to the calibration process (CALWORD), Advanced Features Menu (PASSWORD), and Datalog Features Menu (LOGWORD). By changing the default factory setting of “\*\*\*”, you automatically turn this option on, and password protect that area of the program. If turned on, a code must be entered before one may continue a process. If “\*\*\*” is entered, the password security is turned off. The factory default setting for each password is “\*\*\*”, or disabled.

To add or change the code from the Advanced Features Menu,

1. Press → at the appropriate screen “CHANGE CALWORD”, “CHANGE PASSWORD” or “CHANGE LOGWORD”. The screen will display either three asterisks “\*\*\*”, or the three digit code, with the cursor on the first character.
2. Press ↓ or ↑ to change the first character of the code. You have the option of “\*, 0 through 9”.



### **NOTE**

When entering a CalWord, PassWord, or LogWord all three characters must be a number, 0 through 9. A password containing one or more “\*” is not valid, no security protection is implemented if a password contains an “\*.”

---

3. Press → to accept the setting, and move on to the second character. If you do not want to change the first character, press → to move on to the second character.
4. Repeat the process through the third character.
5. Press ↓ to continue scrolling through the Advanced Features Menu.

### **EXIT**

The ‘EXIT’ screen exits you from the Advanced Features Mode. Press → at “EXIT” to return to the Normal Operating Mode.

## **Datalog Features Menu**

All Genesis versions with optional datalogging include this menu.

The menu is as follows:

- Adjust Date and Time
- Edit Operator IDs
- Edit Location IDs
- Instrument ID
- Log Memory Manager Option
- Log Averages Selection
- Log Interval Selection
- View Log Status
- Clear Log Memory
- View Log Began
- Exit

To enter the Datalog Features Mode:

1. Press and hold both the AIR and BACKLIGHT buttons for three seconds. The screen displays “FEATURES MODE” and counts down from 3 seconds.
2. The first screen displayed after the countdown is “BEGIN CAL”. Press the ↓ button twice. The display will read “DATALOG MENU”.
3. Press the → button. If prompted by “LOGWORD” and “\*\*\*”, enter a LogWord as described earlier in this chapter. When entered correctly, or if LogWord is not enabled, you are now at the first option “ADJUST DATE AND TIME”.



### **NOTE**

The Genesis has a time-out feature. While in the Advanced Features Mode, if a button is not pressed within 10 seconds the display will flash and the buzzer will beep for 10 seconds. If no button is pressed during the 10 seconds, the Genesis will return to The Normal Operating Mode.

---



---

## ADJUST DATE AND TIME

The date and time are adjustable by the user. The default factory settings are Pacific Standard Time. The Genesis uses a 24-hour format to display time. For example, 21:30:00 is 9:30 PM.

To change the date and time from the Datalog Menu:

1. Press → at the screen “ADJ DATE AND TIME”. The date and time will appear, with the cursor on the month that is flashing.
2. Press ↑ or ↓ to change to the correct month. Once you’ve reached the correct value, press → to move to the day of the month. If you choose to keep the setting, as is, press → to move to the year.
3. Continue this process through remaining date and time settings. Once you’ve completed and pressed → past the seconds, the “ADJ DATE AND TIME” screen displays, and your selection has been accepted.

## EDIT OPERATOR, LOCATION, AND INSTRUMENT IDS

The ID’s are used to indicate the Operator and Location of personal when exposed to gases. The information is stored in the datalogging memory for retrieval at a later time. The Genesis has three IDs the user can update:

- The **Operator ID** screen allows the Genesis to reference logged data with 16 different operator codes.
- The **Location ID** screen allows the Genesis to reference logged data with 64 different location codes.
- The **Instrument ID** screen allows you to uniquely identify the Genesis.

The Operator and location IDs are a two row, 8 characters per row, field. Each character accepts A-Z, a-z, 0-9, asterisk (\*), and blank space. The Genesis User Program stores up to 16 Operator and 64 Location IDs.

Each Operator ID is uniquely referenced by a number from 1 to 16. Each Location ID is referenced by a number from 1 to 64. You can accept (and record in the datalog) an Operator and/or Location ID by its reference number. See Chapter 4, Display Mode.

To add or change the Operator and Location ID from the Datalog Menu:



### NOTE

The factory default setting for Operator, Location, and Instrument IDs are blank.

---

1. Press → at the appropriate screen “EDIT OPER IDs”, “EDIT LOC ID”, or “INST ID”. The first ID screen will appear, you can change this screen by pressing → to accept and start editing this ID or you can press ↑ or ↓ to scroll through the other ID screens. Then press → to accept.
2. Press ↓ or ↑ to change the first character of the ID. You have the option of “\*, 0 - 9, A-Z, a-z, and blank”.
3. Press → to accept the character or space, and move to the next character. If you do not want to change the first character, press → to move to the next character.
4. Repeat the process through both rows of characters.
5. Press ↓ to continue scrolling through the Datalog Menu.



**NOTE**

For the Operator ID and Location ID screens, the ID's reference number is displayed on the bottom line. Press the ↑ button to continue scrolling through the various operators and locations you want to display or update. Then press → to edit or update the screen.

---

**LOG MEMORY MANAGER**

This instructs the datalog memory to either overwrite the oldest data, “OVRWRITE ON FULL”, or stop recording data, “STOP ON FULL”, when the memory is full. The factory default setting is “OVRWRITE ON FULL”.



**NOTE**

If you accept “STOP ON FULL”, the Genesis alerts you with a datalog full alarm when the Genesis is no longer recording data. See Chapter 3, Alarms. If you accept “OVRWRITE ON FULL”, the Genesis begins writing over the oldest data when the datalog is full. The overwritten data is not retrievable.

---

To change the setting, from the Datalog Features Menu:

1. Press → at the screen “LOG MEM MANAGER”.
2. Then press ↑ or ↓ to display the correct setting.
3. Press → to accept the setting.
4. Then press → to continue scrolling the Datalog Features Menu.

## LOG AVERAGES

This parameter controls which averages (STEL or TWA) the Genesis stores in the datalog. Available selections for each toxic sensor that is active are:

- LOG ALL - Log both STEL and TWA
- LOG TWA ONLY - Log TWA only
- LOG STEL ONLY - Log STEL only
- NO AVE LOGGING - Neither STEL or TWA are logged

The factory default setting is “LOG ALL”.

To change the setting for logging STEL and TWA from the Datalog Features Menu:

1. Press → at the screen “LOG AVERAGES”.
2. Press ↓ or ↑ to scroll between options until you get to the appropriate screen.
3. Press → to accept the setting.
4. Press ↓ to continue scrolling through the Datalog Features Menu.

## LOG INTERVAL

This parameter instructs the Genesis how often to record data in the datalog. You have the option of 5, 15, 30, 60, 90, 300, or 900 seconds. The factory default setting is “LOG EVERY 60 SECONDS”.

To change the setting for log interval from the Datalog Features Menu:

1. Press → at the screen “LOG INTERVAL”.
2. Press ↓ or ↑ to scroll between options until you get to the appropriate screen.
3. Press → to accept the setting.
4. Press ↓ to continue scrolling through the Datalog Features Menu.

Table 4-1 illustrates approximately how long it takes to fill the datalog for common datalog interval settings.

<b>Sample Interval</b>	<b>Capacity (No Alarm Activity)</b>
5 seconds	18 hours
15 seconds	55 hours
30 seconds	111 hours
60 seconds	9 days
90 seconds	13 days
300 seconds	36 days
900 seconds	108 days

## **LOG STATUS**

This is a display screen only, which indicates the number of datalog hours or days left in memory that is not currently occupied.

To display the number of hours or days left, from the Datalog Features Menu:

1. Press → at the screen “LOG STATUS”. The screen displays reads “XX LOG HRS LEFT” or “XX LOG DAYS LEFT” (“XX” for number of hours or days available in memory). The display will automatically go back to the “LOG STATUS” screen.
2. Press ↑ or ↓ to continue scrolling the Datalog Menu.

## **CLEAR LOG**

To clear the data in the memory, from the Datalog Features Menu:

1. Press → at the screen “CLEAR LOG”. The screen displays “ ↑ AND ↓ TO CLEAR”.
2. Press and hold ↑ and ↓ for three seconds. The display reads “CLEARING LOG” and beeps for several seconds. When complete the display indicates “LOG CLEARED”.



### **NOTE**

If you do not want to clear the log, press the → button and continue scrolling through the Datalog Features Menu.

---



### **CAUTION**

**You cannot recover data after you clear the log. Download all required data before you clear the log.**

---

## **LOG BEGAN**

This screen displays the date and time when the log was last cleared.

To display this data and time, from the Datalog Menu:

1. Press → at the screen “LOG BEGAN”. The screen displays the data and time. For example, “7/12/99 10:00:00”. The display automatically goes back to the “LOG BEGAN” screen.
2. Press ↑ or ↓ to continue scrolling on the Datalog Menu.

## **EXIT**

The ‘EXIT’ screen exits you from the Datalog Features Mode. Press → to exit the menu and return to the Normal Operating Mode.

# CALIBRATION

This chapter describes steps necessary to assemble the calibration kit and calibrate the Genesis. Alarms that may occur during calibration are described at the end of this chapter.



---

## NOTE

For **optimum** performance, calibrate the Genesis before every use. During calibration, on datalogging versions, datalogging is disabled.

---

## Assembling the Calibration Kit

1. Verify that the regulator is closed, then carefully screw the regulator into the gas cylinder.
2. Attach the sample tubing over the fitting on the regulator.
3. Attach the other end of the sample tubing to the calibration cup.

## Calibrating the Genesis

The Genesis offers two calibration options, automatic and manual.

- The **automatic calibration (AUTO CAL)** displays all active sensors on the display screen at the same time. You can calibrate all active sensors simultaneously using a multi-gas cylinder available from **Thermo GasTech**. The concentrations set in the Auto Cal Gas Value screen must match the multi-gas mixture. See Chapter 4, Setting Auto Cal Gas Values.
- During the **manual calibration (MAN CAL)** only one active sensor is displayed on the screen at a time, only one sensor is calibrated during a manual calibration. It is recommended to use a single gas cylinder for manual calibrations. During a manual calibration you may manually change the concentration of the gas before the gas is applied. The default value is that set in the Auto Cal Gas Values screen. See Chapter 4, Setting Auto Cal Gas Values.

## Auto Calibration

---



### NOTE

If you use the automatic adjustment method to calibrate the sensor, make sure the gas cylinder contains the same concentrations of the target gas as the values set in the “AUTO CAL GAS VAL” menu. See Chapter 4, Setting Auto Cal Gas Values.

---

1. In a “fresh air” environment (known to be free of all target gases and of normal oxygen content), hold down the AIR button for 3 seconds until the display reads “DONE” to set the zero reading for all active sensors (20.9 for O<sub>2</sub>).



### NOTE

After you complete the fresh air adjustment, a “XXX” may appear on the display screen in place of a sensor reading. The buzzer and lights will be on steady. See Calibration Alarms section at the end of this chapter to respond to this message.

---

2. Remove the rubber end cap from the sensor end of the Genesis by loosening the captive screw.
3. Attach the calibration cup to the sensor end of the Genesis and tighten the captive screw.
4. Press and hold ↑ and ↓ for three seconds. The “FEATURES” mode counts down from 3, then displays “BEGIN CAL”.
5. Press → to accept and begin a calibration. If a CalWord has not enabled, the “AUTO CAL” screen is displayed. Skip the next section and proceed with Calibrating with the Auto Cal Screen (cont.) on the following page.



### NOTE

If prompted by “CALWORD” and “\*\*\*”, enter a password as described in the next section.

---

---

## Entering a CalWord

A password may be used to add extra security to the Calibration with a “CALWORD”. See Chapter 4, Create/Edit CalWord/PassWord/LogWord. If turned on, a code must be entered before the user may perform a calibration.

To enter a CalWord (if activated):

1. Press and hold ↑ and ↓ for three seconds. The message “FEATURES MODE” appears on the display and counts down from 3, and then displays “BEGIN CAL”.
2. Press → to accept. The display reads “CAL WORD” and “\* \* \*”. The cursor is on the first asterisk.
3. Press ↑ or ↓ to scroll to the correct character.
4. Press → to accept. The cursor moves to the next character.
5. Repeat steps 3 and 4 until all three characters are accepted. If correct, the next display reads “AUTO CAL”. If the CalWord is incorrect, the display reads “BEGIN CAL” message. Begin at step 2 to start over.

## Auto Calibration (cont.)

6. Press → to accept “AUTO CAL”. The screen displays “BEGIN AUTO CAL” alternating with “APPLY GAS” counting down from 30 seconds. If no gas is detected during this period, the screen returns to “BEGIN CAL”.
7. Turn on the regulator and wait for the Genesis to go through the process.

First, the display will read “CAL IN PROCESS” for the first 30 seconds. Then the screen displays “CAL TIME LEFT” (counting down from 45 seconds) alternating with the gas readings.



---

### NOTE

During calibration, on datalogging versions, datalogging is disabled but calibration events are recorded in the logged data.

---

8. When calibration is complete, the display reads “AUTO CAL PASSED” and then alternates between “>ACCEPT, ABORT” and the gas readings. The gas labels alternate with “PASS”. Press → to accept. The display will show “CAL ACCEPTED”, and then alternate between “REMOVE GAS” and the gas readings.

If you choose to abort, press ↓ to scroll to “ABORT” then → to accept the abort option.

The display will read “CAL ABORTED” and then alternate between “REMOVE GAS” and the gas readings.



**NOTE**

The “WEAK” or “FAIL” flag may appear in place of the “PASS” flag in the case of a weak or failed sensor. See the instructions in the Calibration Alarms section, later in this chapter for corrective action.

---

9. Turn the regulator off and remove the calibration cup, reattach the rubber end cap to the Genesis. The display will alternate between “ALARMS SILENCED”, and the readings, and then return to the Normal Operating Mode, after an “ALARMS ACTIVE” message is displayed.
10. Unscrew the regulator from the cylinder. Leave the components of the calibration kit assembled for convenience. Store the kit in the storage case.

### Toxigen Calibration

The Toxigen calibration gases are only available in single-gas cylinders. Therefore a multi-step calibration process has been programmed into the calibration routine. First, the standard sensors are calibrated using a multi-gas mixture. Then the first Toxigen sensor is bumped using a single-gas cylinder, and repeated if your unit has a second Toxigen sensor.



**NOTE**

For pump adapter units, (due to the sensitivity of the sensors), it is required to perform the calibration with the pump adapter attached.

---

A special demand flow regulator (see parts list, Appendix A) is required for the pump to draw the gas from the pressurized cylinder.

---

1. Begin the calibration process by performing an Auto Calibration from the beginning. The Toxigen sensors will be ignored during the multi-gas calibration.
2. When the multi-gas calibration is complete, a double beep prompts the user to begin the first Toxigen sensor calibration. The default gas concentration is displayed with the ADJ icon to indicate you may change the concentration.
3. Press to begin the calibration.
4. Apply the calibration gas and follow the prompt to complete the calibration process. When the first Toxigen is complete, and a second Toxigen sensor is present, a double beep prompts the user to begin the second Toxigen sensor calibration.



**WARNING**

**Avoid using a gas mixture containing H<sub>2</sub>S for calibrating an instrument with Cl<sub>2</sub>, NH<sub>3</sub> or NO<sub>2</sub> sensors.**

**Manual Calibration**

1. In a “fresh air” environment (known to be free of all target gases and of normal oxygen content), hold down the AIR button for 3 seconds until the screen displays “DONE” to set the zero reading for all active sensors (20.9 for O<sub>2</sub>).

**NOTE**

After you complete the fresh air adjustment, a “XXX” may appear on the display screen in place of a sensor reading. The buzzer and lights will be on steady. See the Calibration Alarms section at the end of this chapter to respond to this message.

2. Remove the rubber end cap from the sensor end of the Genesis by loosening the captive screw.
3. Attach the calibration cup to the sensor end of the Genesis and tighten the captive screw.
4. Press and hold ↑ and ↓ for three seconds. The “FEATURES” mode counts down from 3. Then displays “BEGIN CAL”.
5. Press → to accept and begin calibration. If a Calword has not enabled, the “AUTO CAL” screen is displayed.

**NOTE**

If prompted by “CALWORD” and “\*\*\*”, enter a password, see Entering CalWord earlier in this chapter.

6. With the “AUTO CAL” message displayed. Press the ↓ to advance to the “MAN CAL” screen. Press → to accept “MAN CAL”.
7. The screen displays the first active sensor. Press the → to accept or press ↓ to advance to the next gas depending on what sensor you want to calibrate. To accept the desired selection, press →.
8. The default gas concentration is displayed with the ADJ icon and a double beep to indicate you may change the default concentration. The default concentration is set in the Auto Cal Gas Value. See Chapter 4, Setting Auto Cal Gas Values.
9. Press ↑ and ↓ to adjust the value to match the concentration of the calibration gas as read on the cylinder label.

10. Press → to accept the displayed concentration. The display reads “BEGIN MAN CAL” alternating with “APPLY XX GAS” (where XX is the gas selected) and counts down from 45 seconds. If no gas is detected during this period, the screen returns to “BEGIN CAL”.
11. Turn on the regulator, then wait for the Genesis to go through the process.  
First, the display will read “CAL IN PROCESS” for 30 seconds, with the SPAN icon on. Then the screen displays “CAL TIME LEFT” (counting down to 0 seconds) alternating with the gas reading.



---

**NOTE**

During calibration, on datalogging versions, logging is disabled but calibration events are recorded in the log.

---

12. When calibration is complete, the display reads “MAN CAL PASSED” and then alternates between “>ACCEPT, ABORT” and the gas reading. The gas label alternates with “PASS”.
13. Press → to accept. The display will show “CAL ACCEPTED”, and then alternate between “REMOVE GAS” and the all active sensors gas readings.



---

**NOTE**

If the calibration gas used interferes with any of the other sensors a non-zero reading may result, this does not affect the calibration of those sensor(s).

---

14. If you choose to abort, press ↓ to scroll to “ABORT” then → to accept the abort option. The display will read “CAL ABORTED” and then alternate between “REMOVE GAS” and all active sensor gas readings.



---

**NOTE**

The “WEAK” or “FAIL” flag may appear in place of the “PASS” flag in the case of a weak or failed sensor. See the instructions in the Sensor Failed Alarms section later in this chapter for corrective action.

---

15. Turn the regulator off, remove the calibration cup, and reattach the rubber end cap to the Genesis. The display will alternate between “ALARMS SILENCED”, and the readings, and then return to the Normal Operating Mode, after an “ALARMS ACTIVE” message is displayed.
16. Repeat steps 6, 7, and 8 until all required sensors are calibrated.
17. Unscrew the regulator from the cylinder. Leave the components of the calibration kit assembled for convenience. Store the kit in the storage case.

---

## Calibration Alarms

The Genesis may alert you to one or more of the following alarms during calibration:

- Sensor Failed Alarm
- Weak Sensor
- Calibration Incomplete

### Sensor Failed Alarm

If you attempt to air adjust or calibrate a failed sensor, the Genesis alerts you with a Sensor Failed Alarm.

#### INDICATIONS

- The backlight turns on automatically.
- The gas reading is replaced by XXX.
- Lights and Buzzer are steady.

#### RESPONDING TO A SENSOR FAILED ALARM

1. Complete the calibration procedure for the remaining sensors (if applicable), then return to the normal screen. The normal screen will continue to notify you of the sensor failure with a message.
2. Turn off the Genesis, then verify that the sensor is installed properly. See Chapter 6, Replacing/Adding a Sensor. Verify that the calibration gas value is correct.
3. If the calibration gas value is correct, and the sensor is installed properly, turn the instrument on and repeat the air adjust and calibration procedures.
4. If the Fail condition persists, replace the sensor. See Chapter 6, Replacing/Adding a Sensor, then calibrate the new sensor.



#### NOTE

You can enter the Genesis User Program, Advanced Features Menu, and change the sensor status setting to “OFF”. All information for an “OFF” sensor is removed from the normal screen and recorded as a blank in the datalog.

---

### Weak Sensor Warning

If the sensor that you are calibrating is nearing the end of its useful life, the Genesis alerts you with a Weak Sensor message.

## **INDICATIONS**

- The gas flag will show “WEAK” at the conclusion of the calibration period.

## **RESPONDING TO A WEAK SENSOR**

1. If you are manually calibrating the Genesis, verify that you are correctly adjusting the gas concentration to match the concentration of the calibration gas. If using the Auto Cal method, verify that the gas concentration in the calibration gas cylinder matches the Auto Cal Gas Value. See Chapter 4, Setting Auto Cal Gas Values.



## **NOTE**

A weak sensor is still functioning properly and can continue to be used. However, it is near the end of its useful life, and should be replaced as soon as possible. See Chapter 6, Replacing/Adding a Sensor, for replacement instructions.

---

# MAINTENANCE

This chapter includes component replacement and troubleshooting procedures for the Genesis.

## Recharging the NiHy Battery Pack



---

### WARNING

**Recharge the battery pack only in a non-hazardous environment.**

---



---

### CAUTION

**Due to the nature of high capacity NiHy batteries, keep the Genesis on charge when not in use.**

---

1. Verify that the Genesis is turned off.
2. Remove the rubber end cap from the sensor end of the Genesis by loosening the captive screw.
3. Attach the charger boot to the back of the Genesis, and tighten the thumbscrew. Plug the battery charger into an applicable outlet.

The amber light on the battery charger turns on when the battery charger begins recharging the battery pack.



---

### CAUTION

**Use only the battery chargers listed in Appendix A, Parts List, to recharge the battery pack.**

---

4. When the battery pack is fully recharged, the green light turns on (the amber light remains on.)

A completely depleted battery pack recharges in approximately 3 hours. The battery charger automatically cuts the charging current to a sustaining rate when the battery pack is fully charged.

To maintain a fully charged battery, leave the battery charger plugged into the Genesis until you are ready to operate the Genesis.

## Replacing Alkaline Batteries

---



### WARNING

Replace the batteries only in a non-hazardous environment.

To maintain approvals, use only Duracell PC1604.

---

The alkaline battery pack requires three AA alkaline cells to operate. Always replace all three cells as a set.



### NOTE

Use of rechargeable alkaline batteries is not recommended, and will result in decreased operating time.

---

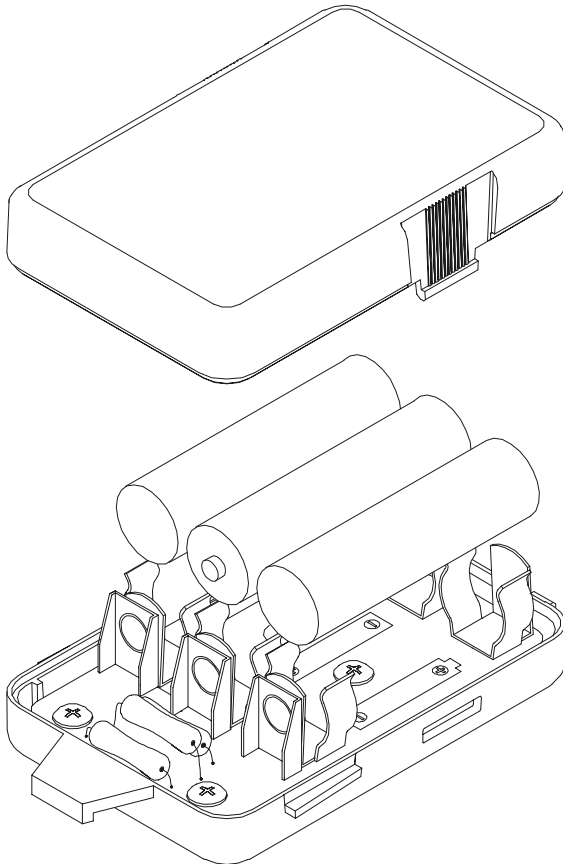

### Figure 6-1 Replacing the Alkaline Batteries

1. Verify that the Genesis is turned off.
2. Loosen the two captive screws that secure the sensor housing to the main housing.
3. Gently pull the sensor housing away from the main housing. Pull straight back, do not rock the two housings.
4. Locate the tab on the battery pack inside the main housing. Using the tab, pull the battery pack out. See Figure 6-1.
5. Squeeze the two tabs on each side of the battery pack cover and lift the cover off.
6. Carefully remove the middle battery with a screwdriver or blunt object, do not damage the PC board below. Then remove the outside batteries with your fingers. Install the replacement batteries in the same position.



#### **CAUTION**

**Make sure you observe correct polarity as you install the replacement cells.**

---

7. Attach the cover to the battery pack and slide the pack into the main housing.
8. Align the main and sensor housing, and then push the two housings together.
9. Tighten the captive screws to secure the sensor housing to the main housing.
10. To test the replacement cells, turn on the Genesis, and verify correct operation.



#### **CAUTION**

**The toxic gas sensor(s) may require up to 15 minutes to stabilize after you replace the alkaline batteries.**

---

## Replacing Components

### Replacing a Sensor



#### NOTE

Toxigen sensors require a special sensor board, and configuration when adding a new Toxigen sensor. Consult **Thermo GasTech** for detailed information on adding Toxigen sensors.

1. Turn off the Genesis.
2. Loosen the two captive screws that secure the sensor housing to the main housing.
3. Gently pull the sensor housing away from the main housing. Pull straight back, do not to rock the two housings.
4. Loosen the two retaining screws inside the sensor housing. If installed, unplug the cable from the pump.
5. Gently lift the sensor board assembly out of the sensor housing using the two retaining screws.
6. Remove the sensor (if applicable), then plug the new or replacement sensor into the appropriate socket. The sockets are labelled with the gas type. Figure 6-2 shows the standard version of the sensor board, your version may be different depending on which model you have.

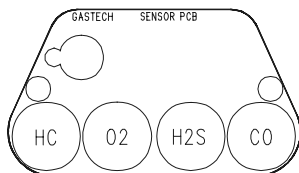

**Figure 6-2 Sensor board**

7. Position the sensor board in the sensor housing.
8. If installed, attach pump cable to sensor board connector. Observe the polarity on the connector, red lead on the connector closest to the sensor board
9. Tighten the captive thumbscrews to reseat the sensor board.
10. Align the main and sensor housing, and then push the two housings together.
11. Tighten the captive screws to secure the sensor housing to the main housing.
12. Turn on the Genesis. After the warm-up period, recalibrate the sensor.





---

**CAUTION**

If you are replacing a toxic gas sensor, allow the sensor to stabilize for 15 minutes before you calibrate the sensor.

---



---

**NOTE**

The Genesis retains the sensor parameters that were last used for the new or replacement sensor. For example, if you are replacing the HC sensor, the Genesis will automatically set the sensor parameters to the same settings as the previous HC sensor.

---

### Replacing the Battery Pack

1. Turn off the Genesis.
2. Loosen the two captive screws that secure the sensor housing to the main housing.
3. Gently pull the sensor housing away from the main housing. Pull straight back, taking care not to rock the two housings.
4. Locate the tab on the battery pack inside the main housing. Using the tab, pull the battery pack out.
5. Slide the new battery pack back into the main housing.
6. Align the main end sensor housing, and then push the two housings together.
7. Tighten the captive screws to secure the sensor housing to the main housing.
8. To test the replacement battery pack, turn on the Genesis and verify correct operation.



---

**CAUTION**

The toxic gas sensor(s) may require up to 15 minutes to stabilize after you replace the battery pack.

---

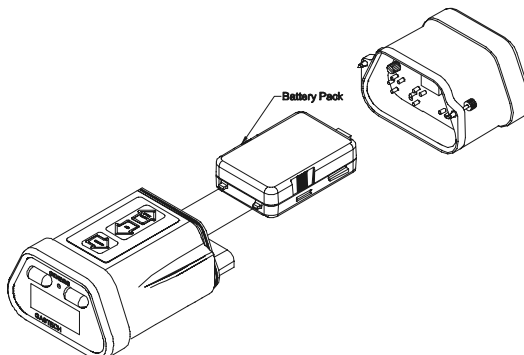

**Figure 6-3 Replacing the Battery Pack**

## Replacing the Pump

1. Turn off the Genesis.
2. Loosen the two captive screws that secure the sensor housing to the main housing.
3. Gently pull the sensor housing away from the main housing. Pull straight back, do not to rock the two housings.
4. Unplug the pump cable and connector from the sensor board.
5. Loosen the two retaining screws inside the sensor housing.
6. Gently lift the sensor board assembly out of the sensor housing using the two retaining screws.
7. Remove the pump from sensor housing. Remove the o-ring from the pump motor.
8. Place the o-ring on the motor of the new pump. Place the new pump in the sensor housing. Insert the pump inlet and outlet nipples through the holes in the housing.
9. Replace the sensor board in the sensor housing. Feed the pump cable and connector through the opening of the sensor board.
10. Tighten the captive thumbscrews to reseal the sensor board.
11. Plug the pump cable into the connector on the sensor board. Observe the polarity of the connector, red lead on the connector closest to the sensor board.
12. Align the main and sensor housing, and then push the two housings together.
13. Tighten the captive screws to secure the sensor housing to the main housing.
14. To test the new pump, install pump adapter, then turn on Genesis. Verify flow through hose and probe.

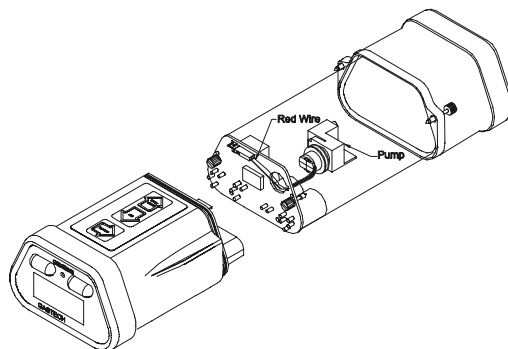

**Figure 6-4** Replacing the pump

## Troubleshooting

The troubleshooting section describes symptoms and probable causes and recommends action for problems you may encounter with the Genesis.

**Table 6-1 Troubleshooting**

Condition	Symptoms	Probable Cause(s)	Recommended Action
No Gas or Gas Reading	<ul style="list-style-type: none"> <li>The gas and gas reading for a particular sensor is not displayed on the normal screen.</li> </ul>	<ul style="list-style-type: none"> <li>The sensor select setting is “OFF”.</li> </ul>	<ol style="list-style-type: none"> <li>Enter the Genesis User Program, Advanced Features Menu, and adjust the sensor select setting to “ON”.</li> <li>If the condition continues, contact <b>Thermo</b> GasTech for further instruction.</li> </ol>
Sensor Failure	<ul style="list-style-type: none"> <li>The alarm light is on.</li> <li>The buzzer is sounding a steady tone.</li> <li>The XXX replaces the reading on the display screen.</li> </ul>	<ul style="list-style-type: none"> <li>The sensor select setting is “ON”, but the sensor is not installed.</li> <li>The sensor is failing.</li> </ul>	<ol style="list-style-type: none"> <li>Verify that the sensor is installed correctly and securely.</li> <li>If the sensor failure continues, replace the sensor, then calibrate the new sensor.</li> <li>If the sensor failure continues after you replace and calibrate the sensor, contact <b>Thermo</b> GasTech for further instruction.</li> </ol> <p>Sensor failures that occur during calibration are described in Chapter 5, Calibration.</p>

52 **Table 6-1 Troubleshooting (Continued)**

Condition	Symptoms	Probable Cause(s)	Recommended Action
Battery Recharging Difficulties	<ul style="list-style-type: none"> <li>The battery pack is not recharging sufficiently.</li> </ul>	<ul style="list-style-type: none"> <li>The battery charger is not connected properly.</li> <li>The battery pack is malfunctioning.</li> <li>The battery charger is malfunctioning.</li> </ul>	<ol style="list-style-type: none"> <li>Verify that the charger adapter is securely connected to the Genesis, and the charger cable is connected to the jack on the charger adapter.</li> <li>Attempt to recharge the battery pack in question with another battery charger. If the difficulty stops, the battery charger is the cause. If the difficulty continues, go to step 3.</li> <li>Attempt to recharge another battery pack with the battery charger in question. If the difficulty stops, the battery pack is the cause. Replace the battery pack. If the difficulty continues, go to step 4.</li> <li>Contact <b>Thermo</b> GasTech for further instruction.</li> </ol>
Sample-draw Pump Difficulties  (Pump fail message will not clear)	<ul style="list-style-type: none"> <li>The alarm light is on.</li> <li>The buzzer is sounding a steady tone.</li> <li>A pump failure message is on the display screen.</li> </ul>	<ul style="list-style-type: none"> <li>The sample flow is restricted.</li> <li>Pump current is too high.</li> </ul>	<ol style="list-style-type: none"> <li>Verify that the pump adapter is firmly seated against the Genesis housing and the screw is securely tightened.</li> <li>Check the hose, probe, and filter for flow restrictions.</li> <li>Press the ON/OFF button to reset the alarm circuit and return to the normal screen.</li> <li>If alarm continues to sound, check pump threshold setting (see Chapter 4, User Program). If setting is “LOW”, change to “HI” and try again.</li> <li>If the pump difficulties continue, contact <b>Thermo</b> GasTech for further instruction.</li> </ol>

**Table 6-1 Troubleshooting (Continued)**

Condition	Symptoms	Probable Cause(s)	Recommended Action
Sample-draw Pump Difficulties  (Pump fail message does not appear when flow is blocked)	<ul style="list-style-type: none"> <li>• Normal operation when probe tip is blocked.</li> </ul>	<ul style="list-style-type: none"> <li>• Leak in sample system.</li> <li>• Pump current is too low.</li> </ul>	<ol style="list-style-type: none"> <li>1. Verify that the pump adapter is firmly seated against the Genesis housing and the screw is securely tightened.</li> <li>2. Check the hose, probe, and filter for leaks.</li> <li>3. If problem continue, check pump threshold setting (see Chapter 4, User Program). If setting is “HI”, change to “LOW” and repeat test.</li> <li>4. If the pump difficulties continue, contact <b>Thermo</b> GasTech for further instruction.</li> </ol>



Appendix  
A

## PARTS LISTS

Table A-1 includes part numbers and descriptions for the GENESIS and replaceable parts of the GENESIS.

**Table A-1 Parts List, Replaceable Parts**

Part No.	Description
13-0215	Belt clip
07-6111	O-Ring, pump
20-2053	Boot, protection, with screw
30-0051	Pump
49-1215	Alkaline battery, AA (3 required)
49-1594-01	Battery pack, NiHy (UL approved units only)
49-1594-02	Battery pack, less batteries, Alkaline (UL approved units only)
49-1594-03	Battery pack, NiHy (UL/CSA/Cenelec approved units)
49-1594-04	Battery pack, less batteries, Alkaline (UL/CSA/Cenelec approved units)
61-0217-02	Hydrocarbon (HC) sensor
65-1061	Oxygen (O <sub>2</sub> ) sensor
65-2007	Carbon monoxide (CO) sensor
65-2037	Hydrogen sulfide (H <sub>2</sub> S) sensor
65-2433	Sensor, Ammonia (NH <sub>3</sub> )
65-2434	Sensor, Chlorine (Cl <sub>2</sub> )
65-2435	Sensor, Hydrogen Cyanide (HCN)
65-2436	Sensor, Nitric Oxide (NO)
65-2437	Sensor, Nitrogen Dioxide (NO <sub>2</sub> )
65-2438	Sensor, Sulfur Dioxide (SO <sub>2</sub> )
65-2439	Sensor, Phosphine (PH <sub>3</sub> )

Table A-2 includes part numbers and descriptions for accessories of the GENESIS.

**Table A-2 Parts List, Accessories**

<b>Part No.</b>	<b>Description</b>
06-1255	Sample tubing (for calibration kit)
13-0113	Shoulder strap with D-ring
20-0110	Storage case (for calibration kit)
20-0250	Carrying case, vinyl (for GENESIS)
20-0608	Storage case, small (without pump version)
20-0609	Storage case, large for pump or extender cable versions
33-0152-01	Filter, hydrophobic (part of probe)
47-1560-01	Extender cable, 20'
47-1560-02	Extender cable, 50'
49-2173	Battery Conditioning Station, 120 VAC
49-2173-01	Battery Conditioning Station, 120 VAC with 6 battery packs
49-2173-02	Battery Conditioning Station, 240 VAC
49-2173-03	Battery Conditioning Station, 240 VAC with 6 battery packs
49-2175	Battery charger, NiHy (115 VAC)
49-2176	Battery charger, NiHy (230 VAC)
49-2177	Battery charger, NiHy (12 VDC)
71-0132	GENESIS Operator's Manual
71-0133	Quick Reference Card
80-0191	Probe (for sample-draw pump)
81-0158	Cylinder (CH <sub>4</sub> , CO, H <sub>2</sub> S, O <sub>2</sub> , and N <sub>2</sub> )
81-0159	Cylinder (CH <sub>4</sub> , CO, O <sub>2</sub> , and N <sub>2</sub> )
81-0170	Cylinder, 5 ppm sulfur dioxide (SO <sub>2</sub> )
81-0175	Cylinder, 25 ppm nitric oxide (NO)
81-0180	Cylinder, 5 ppm nitrogen dioxide (NO <sub>2</sub> )
81-0190	Cylinder, 5 ppm chlorine (Cl <sub>2</sub> )
81-0191	Cylinder, 25 ppm ammonia (NH <sub>3</sub> )
81-0192	Cylinder, 10 ppm hydrogen cyanide (HCN)



**Table A-2 Parts List, Accessories (Continued)**

<b>Part No.</b>	<b>Description</b>
81-0193	Cylinder, 0.5 ppm phosphine (PH <sub>3</sub> )
81-0268-01	Calibration kit (CH <sub>4</sub> , CO, O <sub>2</sub> , and N <sub>2</sub> )
81-0268-02	Calibration kit (CH <sub>4</sub> , CO, H <sub>2</sub> S, O <sub>2</sub> , and N <sub>2</sub> )
81-1003	Regulator (3-gas test kit)
81-1051	Regulator (4-gas test kit)
81-1051-01	Regulator, 0-5 lpm, toxic cylinders, except chlorine (Cl <sub>2</sub> )
81-1062	Regulator, 1.0 lpm for chlorine (Cl <sub>2</sub> )
81-1063	Regulator, 0-3 lpm demand flow, for calibrating with the pump adapter
81-1174	Calibration cup
81-1187	Hand aspirated adapter with hose and probe
81-1188	Pump adapter, with 10' hose and probe
81-1188-01	Pump adapter, with 5' hose and probe
82-5003	Data retrieval kit

